

6A-68 SN-ACSR/AC-OE wire
(A rank)

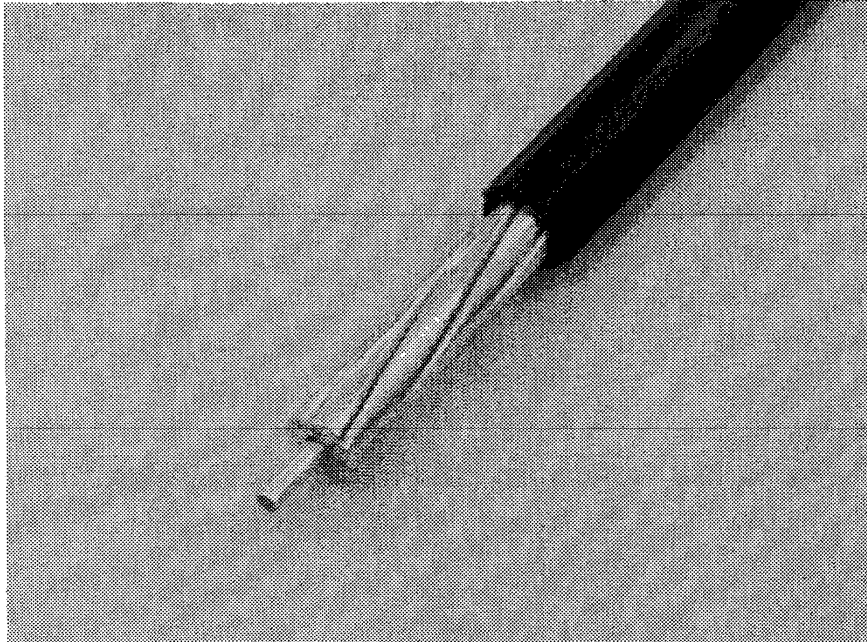

Established in September, 1996
June 15, 2011 (revised 04)
Enforcement on July 15, 2011

Distribution Department
Tokyo Electric Power Company, Incorporated

1. Scope of applications

This specification mainly applies to cables of high voltage overhead distribution lines.

2. Related standards

2.1 Japanese industrial standards

JIS C 3002 (1992)	Electrical copper and aluminum wire testing methods
JIS C 3005 (2000)	Test methods for rubber and plastic insulation wires
JIS C 2110 (2009)	Electrical aluminum metal

2.2 Our standard specification

6A-62 SN-ACSR-OE wires

2.3 Standards for electric power

Standard for electric power C 106-1986 Outdoor polyethylene insulated wire

Standard for electric power C 248-1986 Outdoor steel core aluminum conductor polyethylene insulated wire

Standard for electric power C 2024-1986 Anti-snow-insulated wire

2.4 The Japanese Electric Wire & Cable Makers' Association standard

JCS No. 1389 -2003 Aluminum-covered steel

3. Types and symbols

6 Types are shown by the presence or absence of the cross-sectional area of conductors and recycled materials, as listed in Table 1.

(Note) SN means	Snow Accretion less
ACSR means	Aluminum Conductors Steel Reinforced
OE means	Outdoor Polyethylene Insulated Wire
/R and //R are	abbreviations for Recycle. Furthermore, the meaning of each symbol is as follows. /R: Insulators using polyethylene recycle materials //R: Insulators using cross-linked polyethylene recycle materials

Table 1

Symbol	Nominal cross-sectional area (mm ²)	Remarks
①SN-ACSR-OE	32	①Insulators using polyethylene recycle materials
②SN-ACSR-OE/R	120	②Insulator using cross-linked polyethylene recycle materials
③SN-ACSR-OE//R		

4. Structure and materials

4.1 General matters

This product is a 6600 V anti-snow-shaped outdoor polyethylene insulated wire (hereinafter 'wire') consisting of polyethylene resin compounds (hereinafter 'polyethylene') isolated by conductors.

4.2 Conductors

Conductors shall be based on hard aluminum wires prescribed in 'outdoor steel core aluminum conductor polyethylene insulated wire' of the standard for electric power C 248, 20 AC (2.6 mm aluminum-covered steels) of JCS no.1389, 4.2 mm aluminum-covered steels prescribed by 23AC/1230 or other similar kinds. The conductors shall be a round compression strand mainly composed by aluminum-covered steels, and the direction of an outermost layer twisting shall be right (S) with sufficient flexibility. The outer diameter tolerance of conductors is within $\pm 2\%$ of a value in an attached table. Also, in the case when recycled materials are used for conductors, hard aluminum wires shall consist of the mixture of new aluminum ore and recycled materials, and they shall meet the standard in 'electrical aluminum metals' of JIS H 2110. However, in terms of pollution accumulation and electrical conductivity of recycled aluminum rough drawing wires, the mixing rate of recycled materials shall be 50% or less, and the rate shall be clearly specified on a production specification and a quality management process diagram.

[Commentary]

'Having sufficient flexibility' means that from a conventional knowledge a conductor pitch of the outermost layer is 16 times bigger or less than the outer diameter or something equivalent.

4.3 Insulators

As for insulators, conductors shall be covered concentrically with weather resistant black polyethylene whose thickness is shown as in the attached table 1, and two fins whose dimensions are indicated in the attached figure 1 shall be installed at symmetrical positions of the outer circumference of insulators. Also, there shall be no harmful scratches and bubbles in use. The average thickness of insulators shall be within $\pm 10\%$ of the tolerances value in the attached table 1, and the minimum measurement value shall have greater than 80% of the value of the attached table 1.

Also, the size of a fin shall be as in a value of the attached table 1, and its tolerance shall be within $\pm 20\%$ of the value. The outer peripheral and bottom parts shall be made round indicated in the attached figure 1.

Furthermore, thermoplastic materials by using cross-linked polyethylene coating materials from the removed parts of power distribution equipment of our company (in the rest, we called them as XLPE recycled materials) and recycled polyethylene mixed with polyethylene raw material shall be used for insulators. However, each mixing rate shall be as in the following, and the rate shall be clearly specified in the production specification and a quality management process diagram.

- (1) If XLPE-recycled materials are used,
the mixing rate of XLPE recycled materials shall be 25% of the total, and new materials are used for the rest.
- (2) If recycled polyethylene materials are used,
the mixing rate of recycled polyethylene materials shall be 40% of the total, and new materials are used for the rest.

4.4 Dimensions

Dimensions are based on the attached table 1 as a standard.

5. Performance

The performance of this product is according to Table 2 and the attached table 1 when a test mentioned in Section 7 is carried out.

Table 2

Item		Performance	Test method applied section
Conductor resistance of conductor		Values in the attached table 1 or less	7.3
Withstand voltage		The test voltage can be tolerated for 1 minute.	7.4
Resistance of insulators		Values in the attached table 1 or more	7.5
Tracking resistance		The current more than 0.5 A shall not flow during 101 times of spraying. Also, the fire shall not be flared up.	7.6
Tensile strength of insulating materials		10 MPa or more	7.7
Elongation of insulators		More than 350%	
Thermal resistance	Tensile strength	More than 80% of a value before heating	7.8
	Elongation	More than 65% of a value before heating	
Thermal deformation resistance		Thickness reduction rate is 10% or less	7.9
Tensile load for conductors		Values in the attached table 1 or more	7.10
Salt resistance performance (salt water immersion)		That no significant rust and corrosion. Also, when wound around, cracks, separations, scums, etc. on the aluminum layer shall not be observed.	7.11

6. Wire display

On the surface of wires, display continuously by embossing the following items at the interval of less than 60 cm.

Furthermore, names are based on Table 1 as a standard.

- (1) Nominal voltage 6600 V
- (2) Example of a name : SN-ACSR/AC-OE
- (3) Name of manufacturer or its abbreviation
- (4) Year of production Example : 2011

7. Test method

7.1 Visual test

A visual test is performed based on Section 4.1 of JIS C 3005.

7.2 Structure test

A structure test is performed based on Section 4.3 of JIS C 3005.

7.3 Conductor resistance test

A conductor resistance test is performed based on Section 4.4 of JIS C 3005.

7.4 Withstand voltage test

A withstand voltage test is performed based on Section 4.6 a) of JIS C 3005. Furthermore, a test voltage shall be 12000V, and a voltage application time shall be 1 minute.

7.5 Insulation resistance test

An insulation resistance test is performed based on Section 4.7.1a) of JIS C 3005.

7.6 Tracking resistance test

An insulation resistance test is performed based on Section 4.13 of JIS C 3005.

7.7 Insulator tensile test

A tensile test is performed based on Section 4.16 of JIS C 3005. A tensile speed is based on Table 4-B from Section 4.16 of JIS C 3005.

7.8 Heating test of insulators

A tensile test is performed based on Section 4.17 of JIS C 3005. A heating temperature and a heating time are based on Table 5-A from Section 4.17 of the JIS C 3005.

7.9 Heat deformation test

A heat deformation test shall be performed by Section 4.23 of JIS C 3005. Here, specimens are 30 mm-long cable samples, a heating temperature is 75 ± 3 °c, and a load is as in Table 3.

Table 3

Conductor cross-sectional area (mm ²)	Load (N)
32	19.6
120	24.5

7.10 Conductor tensile test

A conductor tensile test shall be performed by Section 5 of JIS C 3002.

7.11 Salt resistance performance test

The following test shall be performed on aluminum-covered steel wires taken from a completed electric wire.

The 30cm-long sample is cut out and put vertically into a container having a solution (5% NaCl solution). The test shall be consisting of immersing a sample into the solution whose depth is 20 cm (A level) for a day and immersing the sample into the solution whose depth is 13 cm (B level) for six days as one test cycle to perform a drying and wetting process. The test shall be carried out at 60 °c in a constant-temperature water bath. The solution shall be replaced with a new one per cycle.

After repeating this cycle for ten times, when the sample is taken out and investigated the state of corrosion, no significant rusts and corrosion shall be observed. Also, after immersion of the sample, when a part containing the variation range of a liquid level (between A and B levels) is wrapped more than twice around a cylindrical rod whose diameter is five times bigger than the diameter of the sample, no cracks, separations, scums, etc. shall be observed on an aluminum layer.

<Testing condition>

Constant-temperature water bath

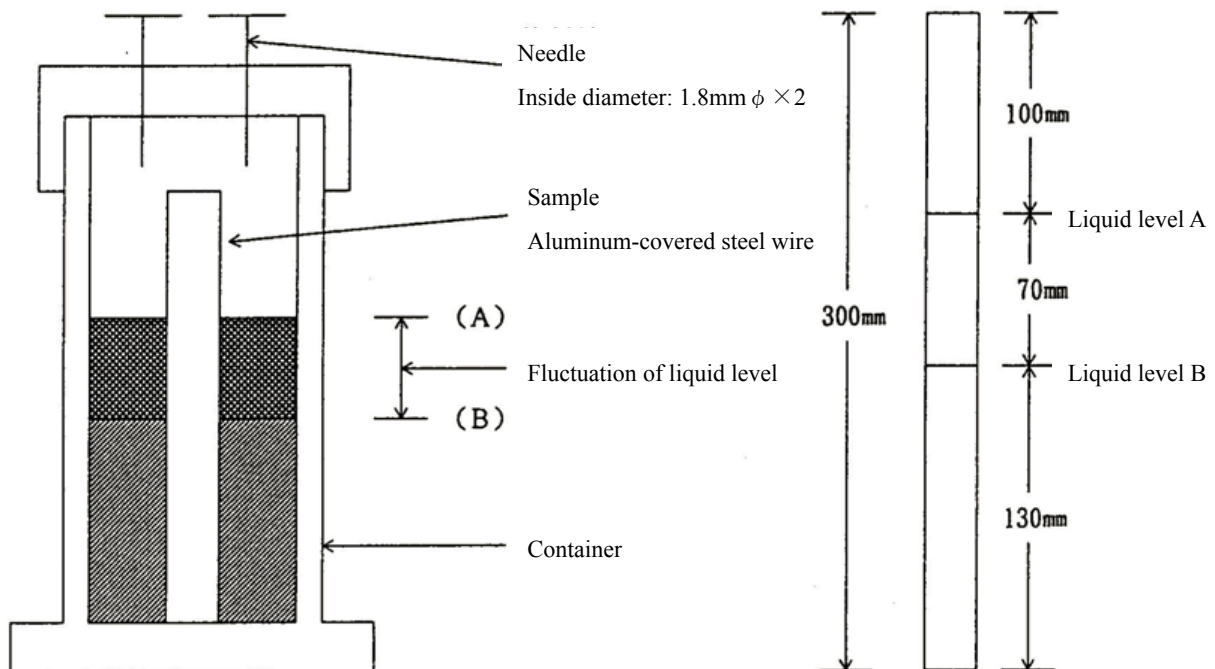

7.12 ACSR characteristics test

This test is meant for inspecting the characteristics of strands prior to standing, and the following items are performed.

(1) Hard aluminum wire

a. Appearance inspection

When checked by 'Section 3. Appearance' from 'the electrical copper wire and aluminum wire test methods' of JIS C 3002, the following shall be confirmed.

(a) A surface is smooth, and there are no scratches, rust, tears and other inappropriate faults in use.

(b) A connection point shall not exist. However, what is finished completely in wire drawing work is not the case.

b. Dimensions inspection

When checked by 'Section 4. Structure' from 'the electrical copper and aluminum wire test methods' of JIS C 3002', 'Table 1' of 'outdoor steel core aluminum conductor polyethylene insulated wire (ACSR-OE)' of standard for electric power C 248 shall be confirmed.

c. Tensile test

When checked by 'Section 5. Tension' from 'the electrical copper and aluminum wire test methods' of JIS C 3002', 'Table 1' of 'outdoor steel core aluminum conductor polyethylene insulated wire (ACSR-OE)' of standard for electric power C 248 shall be confirmed.

d. Electrical conductivity test

When checked by 'Section 6. Electrical conductivity' from 'the electrical copper and aluminum wire test methods' of JIS C 3002', 'Table 1' of 'outdoor steel core aluminum conductor polyethylene insulated wire (ACSR-OE)' of standard for electric power C 248 shall be confirmed.

(2) Aluminum-covered steel

a. Appearance test

When checked by 'Section 3. Appearance' from 'the electrical copper wire and aluminum wire test methods' of JIS C 3002, the following shall be confirmed.

(a) A surface is smooth, and there are no scratches, rust, tears and other inappropriate faults in use.

(b) A connection point shall not exist.

b. Dimension test

When checked by 'Section 4. Structure' from 'the electrical copper wire and aluminum wire test methods' of JIS C 3002, the attached table 2 shall be confirmed.

c. Tensile test

When checked by 'Section 5. Tension' from 'the electrical copper wire and aluminum wire test methods' of JIS C 3002, the attached table 2 shall be confirmed.

d. Electric conductivity

When checked by 'Section 6. Electrical conductivity' from 'the electrical copper wire and aluminum wire test methods' of JIS C 3002, the attached table 2 shall be confirmed.

e. Torsion test

When tested by 'Section 9.2.3 Torsion test' from 'galvanized steel strand' of JIS G 3537, the attached table 2 shall be confirmed.

f. Plating test

When the following two tests are performed, the attached table 2 shall be confirmed.

(a) Aluminum thickness

As for aluminum thickness measurement, cut out a specimen from one used end of a sample, make a flat surface perpendicular to the strand axis by polishing, and measure the minimum thickness of aluminum with an enlarged projector or a measuring microscope.

(b) Winding test

Cut out a specimen from one end of the sample, wrap it closely around a cylindrical rod whose diameter is five times more than the diameter of the specimen for eight times, and examine the exterior of an aluminum layer.

7.13 Test for the degree of cross-linking

When XLPE recycled materials are used for insulators, a test for the degree of cross-linking shall be performed to the

XLPE recycled materials after heat plasticization. The test shall be performed based on Section 4.25 of JIS C 3005, and the degree of cross-linking shall be 40% or less.

8. Test and inspection

8.1 General matters

Section 8.2 Model test, Section 8.3 Manufacturing process inspection and Section 8.4 Acceptance test shall be performed by using Section 7 Test method, and these products must pass all the above provisions.

8.2 Model test

To confirm manufacturer's quality standards, a model test is carried out as in the following test items, and the test must conform to the provisions of Sections 4, 5 and 6. Furthermore, a sample shall be a finished product having a standard length, and three or more test specimens shall be taken for each test.

- (1) Appearance test
- (2) Structure test
- (3) Conductor resistance test
- (4) Withstand voltage test
- (5) Insulation resistance test
- (6) Tracking resistance test
- (7) Insulator tensile test
- (8) Heating test of insulators
- (9) Heat deformation test
- (10) Conductor tensile test
- (11) Salt resistance performance test (salt water immersion test)
- (12) ACSR characteristics test
- (13) Cross-linking degree examination (for XLPE recycled materials)

8.3 Manufacturing process inspection

In performing a model test, to confirm that the exactly same product as a model test product is produced in a production process, a series of inspections such as materials used, quality management items of each production process, quality control methods, defect countermeasures, quality management systems, etc. shall be generally carried out.

8.4 Acceptance inspection

Acceptance inspection shall be performed by a method described in 'Section 8.2 Model test' under supervision if it is directed by our company. Also, specific test items and a sampling rate are consulted with customers at delivery destinations. If the acceptance inspection is carried out without any supervision, manufacturers shall perform an in-house test predetermined after consultation with our company and submit a test report to customers at delivery destinations.

9. Other

9.1 General matters

- (1) Except for items prescribed in this specification, necessary items to satisfy product performance and functionality shall be determined after consultation with our company.
- (2) This specification can be changed with our company's approval if substantial profits are expected for use and in manufacturing by changing a part of it.
- (3) When deemed necessary by our company, process on-site and material inspections, etc. can be performed.

9.2 Packing method

- (1) During transportation, suitable packing is necessary to prevent from being damaged by wrapping with plastic drums or wooden drums whose dimensions are indicated in the attached table 1. Furthermore, in the case of plastic drums, ones specified by our company shall be used, and in the case of wooden drums, ones by the Japanese Electric Wire & Cable Makers' Association (JCS) shall be used.
- (2) A label confirming to one shown in the attached figure 2 should be attached on a plastic drum.
- (3) The following items shall be displayed on the side of a wooden drum in an appropriate way that they cannot be erased easily. Furthermore, a name is based on Table 1 as a standard.
 - a. Name: Example : SN-ACSR/AC-OE
 - b. Nominal cross-sectional area: Example: 32 mm²
 - c. Length: (m)
 - d. Net mass: (kg)
 - e. Total mass: (kg)
 - f. Name of manufacturer or its abbreviation
 - h. Date of production: Example : 2011.5

9.3 Load of testing products

A product used for testing, specimens and implementation costs shall be paid by the deliverers.

9.4 Documents to be submitted

9.4.1 Production specification

In order that our company evaluates compliance with this specification, the following (1)-(5) and necessary items shall be stated in a production specification specifically, and a figure with dimensional tolerances and materials shall be attached. Also, technical references according to the production specification shall be attached if necessary.

- (1) Conductor: Materials, configurations, outer diameter, performance, pitch
- (2) Insulator: Guarantee limit of materials, performance, scratches and bubbles on the surface of coating, etc.
- (3) Display: Display method
- (4) Finished outer diameter: Wire core outer diameter
- (5) Packing: Method, dimension, display

9.4.2 Test result list

A model test described in Section 8.2 shall be carried out, and its result and test conditions shall be stated.

9.4.3 Quality management report

Contents concerning to materials used, quality control items for each production process, quality control methods, defect countermeasures, quality management systems, etc. shall be specifically described in ‘quality management process diagram’, ‘outsourced supplier management’, etc. Furthermore, in the case when main production processes are outsourced, outsourced process control documents (that show the status of outsourced process managements and is described as in the format of a management process diagram) shall be submitted. The scope of a specific description shall be consulted with our company.

9.4.4 Technical references

For the model review, to determine product performance and quality adequately and properly, the following technical references shall be submitted. Also, submission of technical references other than the below is sometimes requested.

- (1) Technical back data about long-period weather resistance of insulators
- (2) In the case of using recycled materials for conductors, the technical description of the following items shall be reported individually.
 - (a) Rationale behind the mixing ratio of recycled materials
 - (b) Quality assurance in the case of recycling repeatedly
- (3) In the case of using recycling materials for insulators, the technical description of the following items shall be reported individually.
 - (c) Conditions for thermoplasticity
 - (d) Quality assurance after repeatedly recycling
 - (e) Technical references on removing foreign substances and impurities of recycled materials and quality control methods

(The section below is intentionally left blank.)

Attached table 1

Conductor	Nominal cross-sectional area (mm ²)		32	120
	Strand configuration (The number of strands/mm)	Aluminum	6 / SB	6 / SB
		Steel wire	1 / 2.6	1 / 4.2
Outer diameter (mm)		7.2	13.6	
Thickness of a polyethylene insulator(mm)			2.0	2.5
Dimension of a fin part (height × width) (mm)			1.0 x 1.0	1.0 x 1.0
Finished outer diameter (mm)			11.2 x 13.2	18.6 x 20.6
Approximate mass (kg / km)			190	560
The maximum resistance of a conductor at 20 ° c (Ω / km)			0.928	0.250
Insulation resistance 20 ° c (M Ω, km)			1500	1000
Tensile load for a conductor (kN)			11.17	32.34
Remarks	Standard strip length (m)		1000	790
	Packing	Plastic drum (company designation)	RP6—6	RP8—6
		Wooden drum (the Japanese Electric Wire & Cable Makers' Association standard)	L6—6	L8—6

- Remarks
- 20% of electrical conductivity of aluminum-covered steels shall be ignored, and their conductor resistance shall be calculated by letting electrical conductivity be as 61%.
 - A lay ratio used for calculating mass and resistance of a conductor shall be set as 2.0% for aluminum wires.
 - A tensile load shall be calculated by setting 90% of the sum of the minimum tensile load of electrical hard aluminum wires multiplied by the number of strands and the tensile load of aluminum covered steel wires.
 - The location to measure the dimension of a fin part shall be as in the attached figure 3.

Attached table 2

Diameter	(mm)	2.6	4.2
Diameter tolerance	(mm)	± 0.05	± 0.05
Tensile strength	(MPa)	1324	1226
Elongation	(%)	1.5 or more	1.5 or more
Electric conductivity	(%)	20.3 or more	More than 23
The number of torsions	(Times)	20 or more	16 or more
Aluminum properties	Minimum aluminum thickness (mm)	0.12	0.23
	Winding test	No significant cracks on the aluminum layer of a specimen shall occur.	
Remarks	Standard aluminum thickness (mm)	0.17	0.34
	Cross-sectional area (mm ²)	5.309	13.85
	Mass (kg / km)	34.67	86.84
	Tensile load (N)	7029	16980

- Remarks
1. Numerical values in this table are obtained at 20 °.
 2. A cross-sectional area, a mass and a tension shall be for the zero tolerance of a diameter.
 3. A density shall be 6.53g per 1 cm³ (2.6 mm) or 6.27g (4.2 mm).
 4. A constant mass resistance temperature coefficient at 20 °c shall be 0.0036 per 1 °c.

Attached Figure 1

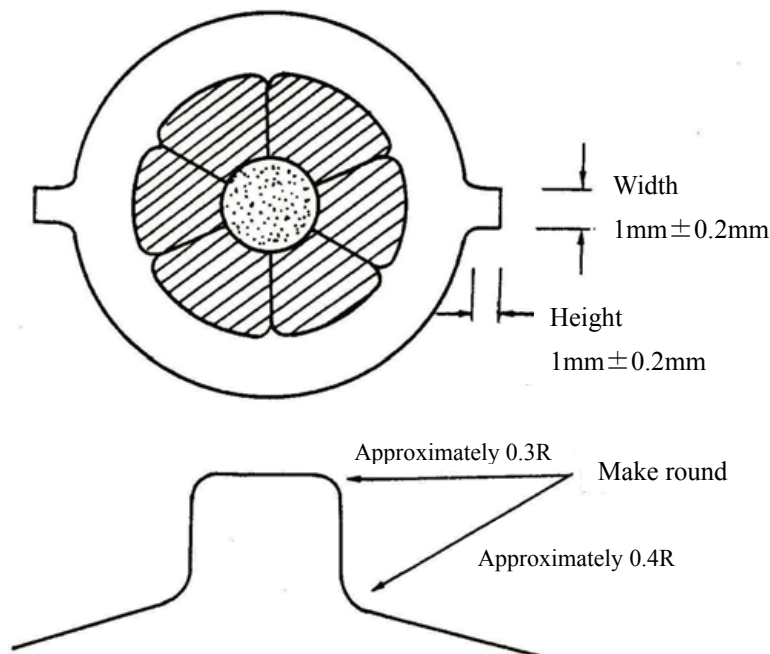

- (Note) 1. Fins shall be installed at symmetrical positions.
 2. The outer circumference of a fin and its bottom part shall be rounded.

Attached Figure 2



- (Note) 1. Both sides of the drum shall be labeled.
 2. The color of the label shall be white.
 3. Even though a drum is left outside for three months after delivery, the color and display of a label can be identified without coming off, and such a label shall be used.

Attached Figure 3

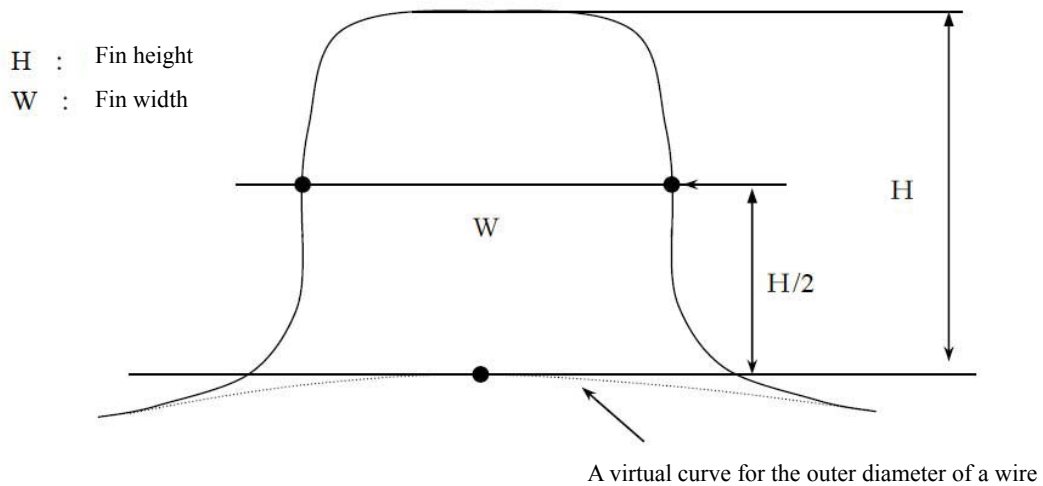

(Note) : The dimension measuring position of a fin part

- (1) Fin height A virtual curve for the outer diameter of a wire and the shortest part of the top of a fin shall be measured.
- (2) Fin width Width shall be measured at the half of the fin height measured in (1).