

6E-43 CABLE BAND (C RANK)



Hook bolt type



Turnbuckle type

December 1960	Established
September 1993	Revised
September 2004	Revised

Distribution Department

TEPCO Power Grid, Incorporated

1. General provisions

1.1 Scope

This specification shall apply to metal parts used to set up utility poles and support pull-down cables for underground electric lines.

1.2 Types

The types shall be as shown in Table 1.

Table 1

Type \ Item	Length of main body of band (mm)	
	Small	Large
Hook bolt type	1,200	1,500
Turnbuckle type	910	1,310

2. Structure and materials

2.1 General matters

- (1) There shall be no scratches, cracks, rust or other inadequacy for finishing.
- (2) In hot dip galvanizing areas, the surface shall be smooth and the plating shall be evenly applied.

2.2 Shape and dimensions

This product consists of a band and a hook or buckle. It is structured to wind an extra length by fastening the hook or buckle to one of the holes provided on the center line of the band, and then tightening the bolt. The standard shape and dimensions for hook type shall be as shown in Attached drawing 1 and those for turnbuckle type shall be as shown in Attached drawing 2. The dimensions of each component shall satisfy the specifications below. The allowable tolerance shall be within the range causing no practical harm.

- (1) Total finished length of band

When the components are assembled to form the product, the minimum finished dimensions shall be as follows:

Large: 1,460 mm

Small: 1,060 mm

- (2) Band hole

Make holes (14 mm x 12 mm) at intervals of 11 mm on the center line of the band in the whole circumference, referring to Attached drawing 1 and 2 as a standard.

- (3) Hook and buckle

The hook and buckle shall be shaped to be easily attached to the holes of the band, and shall be structured so that they can be tightened with a wrench or a ratchet. Also, they shall have a structure so that the length can be adjusted using a bolt for at least 50 mm, with all the components assembled.

(Reference Translation)

[Explanation]

The shape “to be easily attached to the holes of the band” means, as a standard, the width of the hanger portion of the hook or buckle measuring approximately 10 mm.

2.3 Provisions on principal structural part

(1) Band

For material, use steel materials that satisfy the functional characteristics of the product.

[Explanation]

The “steel materials that satisfy the functional characteristics of the product” include SS400 specified in “JIS G 3101 (Rolled steels for general structure).”

(2) Bolts and nuts

For material, use steel materials that satisfy the functional characteristics of the product.

[Explanation]

The “steel materials that satisfy the functional characteristics of the product” include SWCH17R specified in “JIS G 3539 (Carbon steel wires for cold heading and cold forging)” for the hook bolt type and SWCH8R specified in “JIS G 3539 (Carbon steel wires for cold heading and cold forging)” for the turnbuckle type.

(3) Anti-falling ring

For material, use rubber that satisfies the functional characteristics of the product.

[Explanation]

The “rubber that satisfies the functional characteristics of the product” includes NBR (acrylonitrilebutadiene synthetic rubber).

2.4 Surface treatment

Apply hot dip galvanized coating specified in “JIS H 8641 (Hot dip galvanized coatings)” over the entire surface of the product.

2.5 Indication

Indicate the following information clearly at an easily viewable place of the product in such a manner that it is not easily removable:

- (1) Production year: (Example) 04
- (2) Name or abbreviation of manufacturer
- (3) Size: (Example) Large, small

3. Performance

3.1 Material test performance

When the material strength test in Section 4.4 is conducted, the material strength performance of the band shall be as shown in Table 2.

Table 2 Material test performance

	Tensile strength	Proof stress	Elongation	Bending performance
	400 N/mm ² or more	245 N/mm ² or more	21% or more	No cracks or chipping is allowed.
Test method	JIS Z 2241			JIS Z 2248

3.2 Strength test performance

When the strength test in Section 4.5 is conducted, the load resistant power with the product assembled shall be as shown in Table 3.

Table 3 Strength test performance

Test type	Test load	Performance
Tensile test	9,810N	There shall be no cracks, chipping, or extreme deformation after 3 minutes.

3.3 Bolt strength test performance

When the bolt strength test in Section 4.6 is conducted, the tensile load performance of the bolt shall be as shown in Table 4.

Table 4 Bolt strength test performance

Test type	Hook bolt (Hook bolt type)	Double-end stud (Turnbuckle type)
	Minimum tensile load	
Tensile test	23,200N	33,700N
Test method	JIS B 0401	

3.4 Surface treatment test performance

When the hot dip galvanizing test in Section 4.7 is conducted, the coating mass of the hot dip galvanizing shall be 350 g/m² or more, except bolts and nuts.

4. Test and inspection method

4.1 General matters

To determine if the product has an acceptable quality, the test items described below shall be performed as a performance test, and the product shall pass all the items.

4.2 Appearance inspection

Examine all the components by visual observation and touching to check that the appearance complies with “2.1 General matters.”

4.3 Structural inspection

Examine each component by visual observation or using an appropriate measuring apparatus or method, to check that the shape and dimensions comply with “2.2 Shape and dimensions.”

4.4 Material strength test

Cut out a test piece from the material to be used for the band, and perform a test according to JIS Z 2241 (Metallic materials-Tensile testing-Method of test at room temperature) and JIS Z 2248 (Metallic materials-Bend test), to check that the product complies with “3.1 Material test performance.”

4.5 Strength test

In a state where an iron pipe of $\phi 115$ mm is in close contact with a utility pole or a jig having the same diameter, attach the product as shown in Figure 1 and tighten using a standard tool. After that, apply a tensile load of 9,810N to check that the product complies with “3.2 Strength test performance.” At the same time, check the state of the band and record the results.

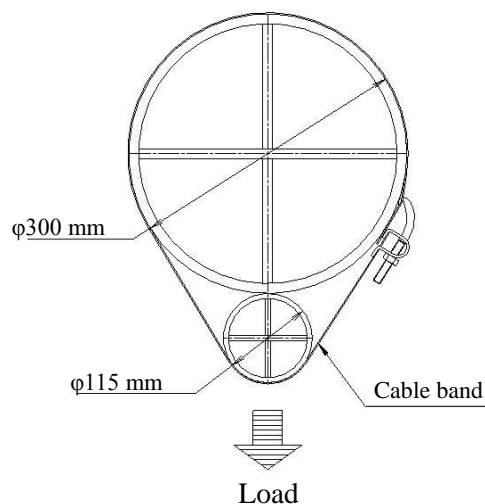

Figure 1 Example of load test

(Reference Translation)

4.6 Bolt strength test

Perform a tensile test of the bolt according to JIS B 1051 (Mechanical properties of fasteners made of carbon steel and alloy steel) to check that the bolt complies with “3.3 Bolt strength test performance.”

4.7 Surface treatment test

Measure the coating mass by the antimony chloride method specified in JIS H 0401 (Test methods for hot dip galvanized coatings) or the coating thickness test method specified in the reference of the same JIS (average of values at any given 5 places) to check that the product complies with “3.4 Surface treatment test performance.”

For the specimen of the coating mass test, appropriate test pieces may be created in advance. The test pieces shall be coated in the same procedure of the same manufacturing process as the product.

5. Test

5.1 Type test

For the type test, the test items below shall be tested for 3 specimens of the same type. The results shall be recorded in writing and reported.

- (1) Appearance inspection
- (2) Structural inspection
- (3) Material strength test
- (4) Strength test
- (5) Bolt strength test
- (6) Surface treatment test

5.3 Acceptance inspection

The test items of acceptance inspection shall be as shown below. A part or all of the following tests may be omitted when TEPCO determines to do so:

- (1) Appearance inspection
- (2) Structural inspection
- (3) Strength test
- (4) Bolt strength test
- (5) Surface treatment test

6. Related standards

6.1 Japanese Industrial Standards

- (1) JIS B 1051 (1991) - Mechanical properties of fasteners made of carbon steel and alloy steel
- (2) JIS G 3101 (1995) - Rolled steels for general structure

Attached drawing 1 Hook bolt type (Unit: mm)

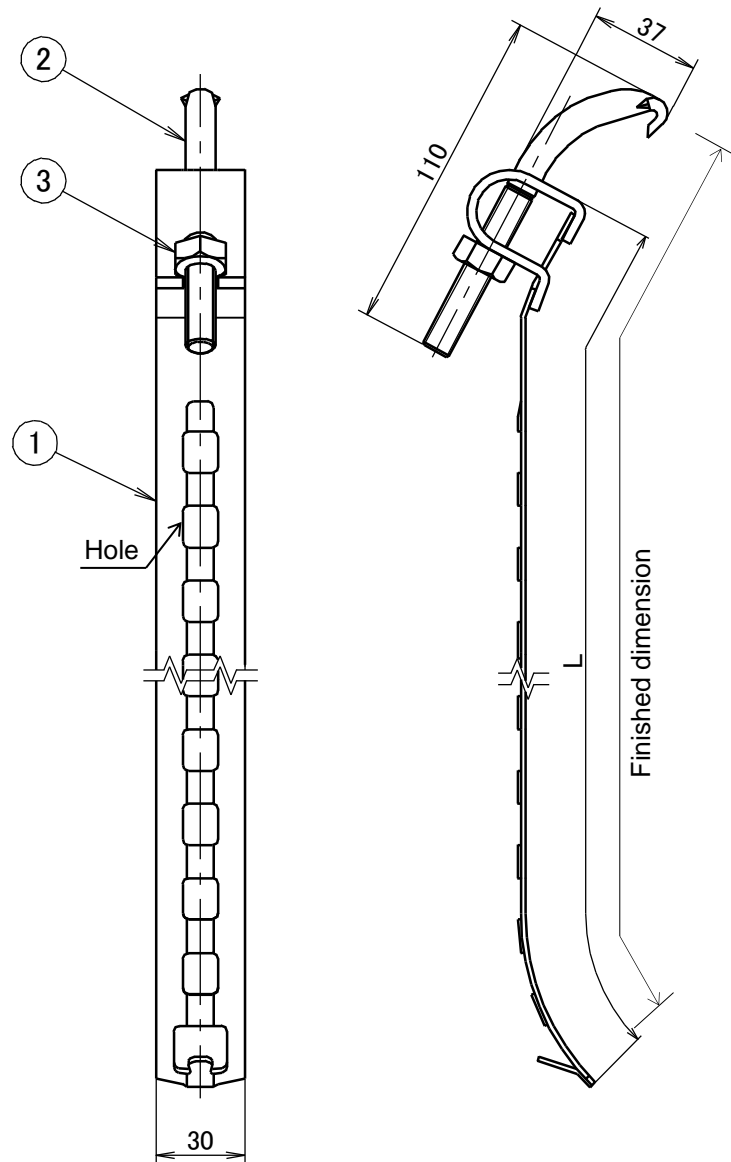

Type	L	No. of holes
Small	1,200	44
Large	1,500	56

No.	Item name	Qty	Remarks
①	Band	1	—
②	Hook bolt	1	M10
③	Hexagon nut	1	M10

1. Band

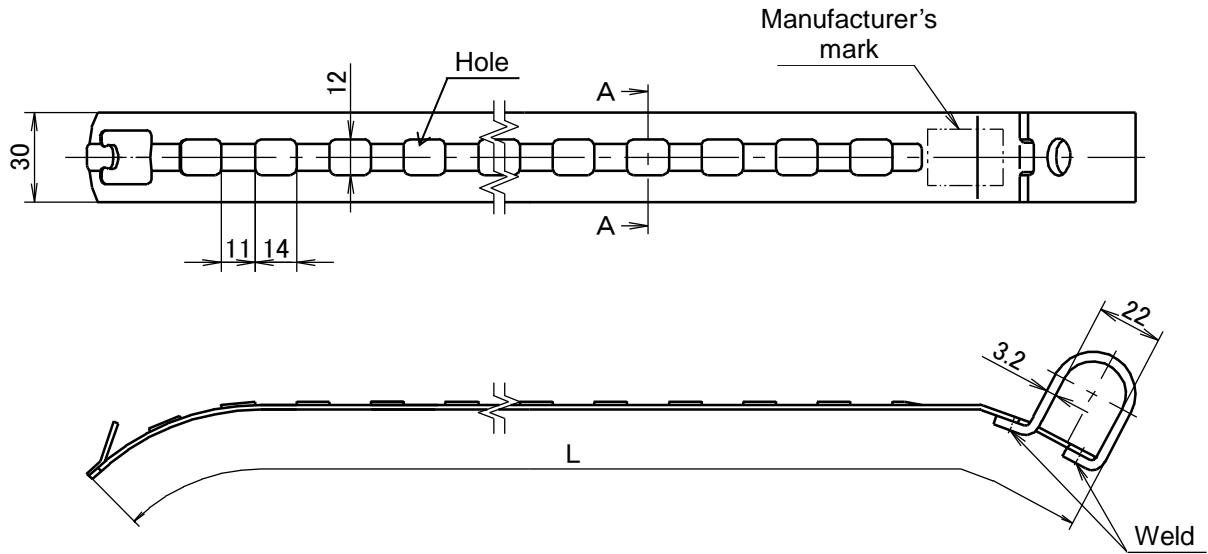

A-A (enlarged view)

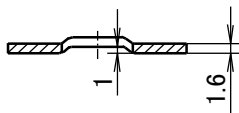

Type	L	No. of holes
Small	1,200	44
Large	1,500	56

2. Hook bolt

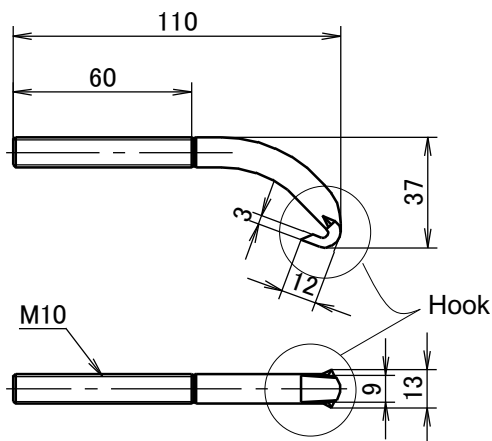

3 Hexagon nut

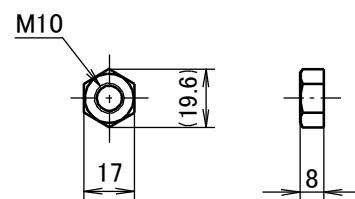

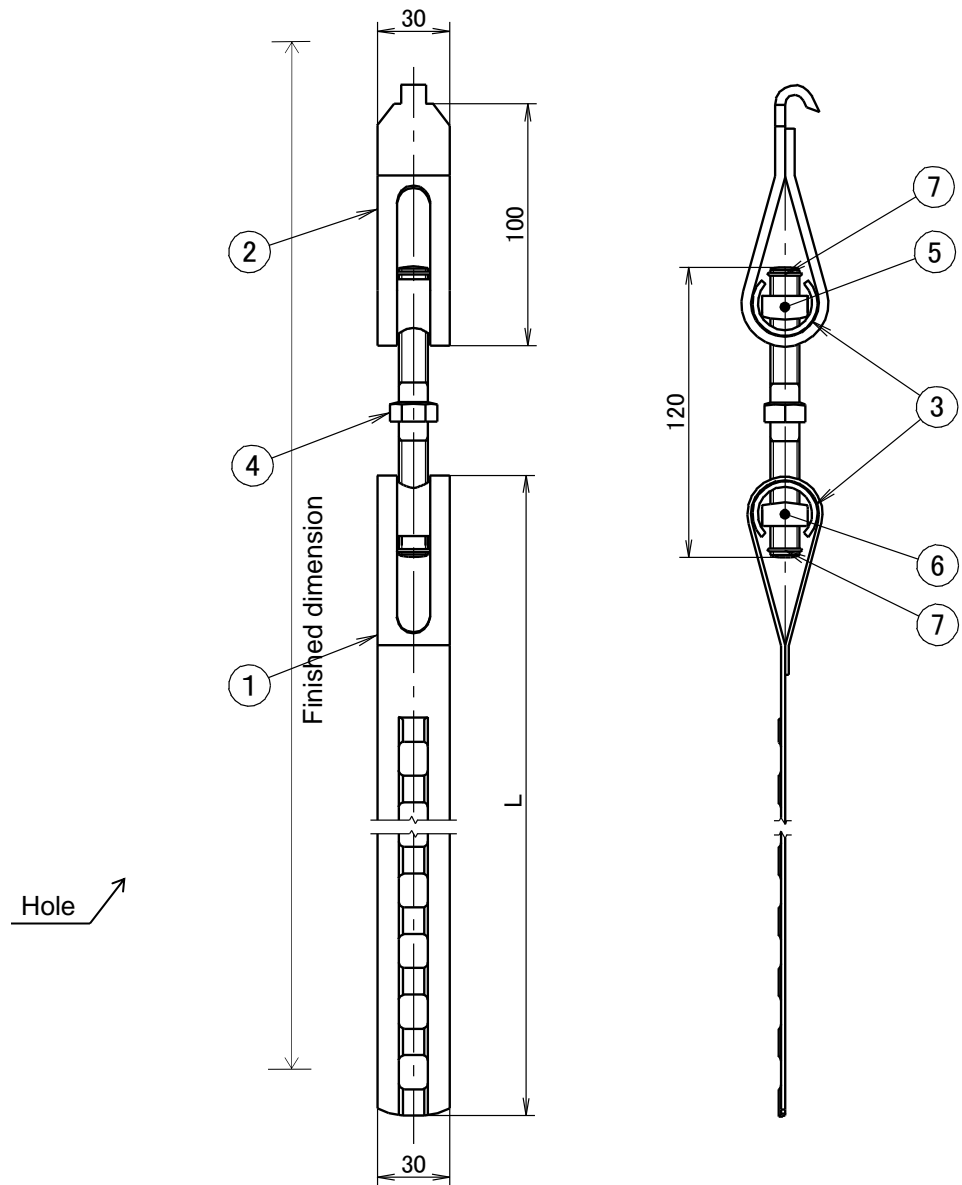

Type	L	No. of holes
Small	910	32
Large	1,310	48

No.	Item name	Qty	Remarks
①	Band A	1	—
②	Band B	1	—
③	Collar	2	—
④	Double-end stud	1	M12
⑤	Square nut	1	M12 (left-hand thread)
⑥	Square nut	1	M12 (right-hand thread)
⑦	Anti-falling ring	1	Rubber

1. Band A

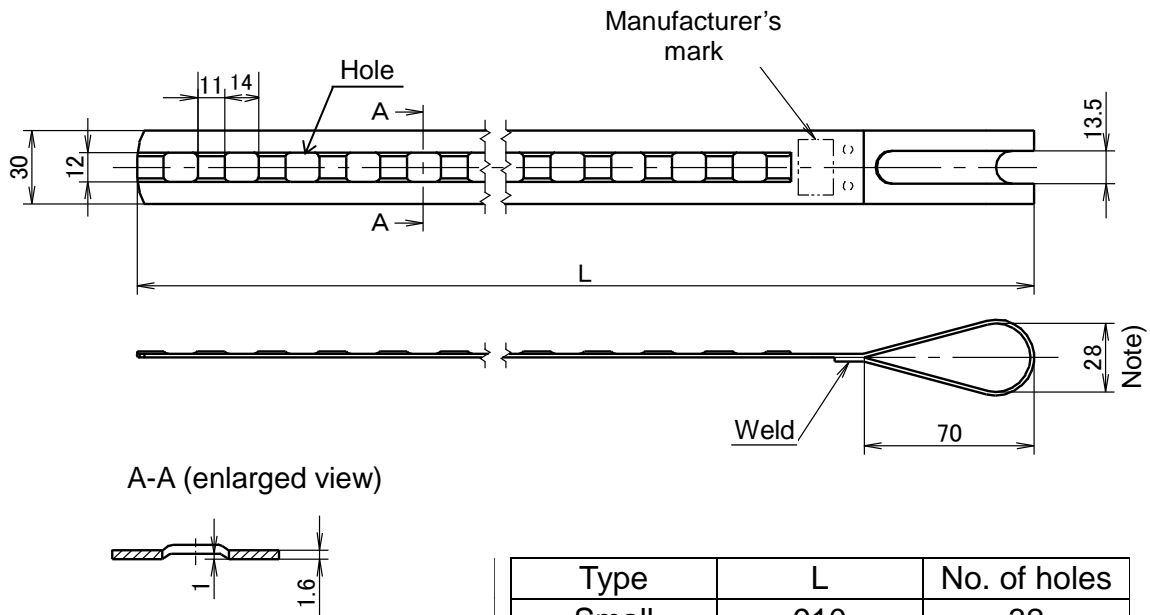

Type	L	No. of holes
Small	910	32
Large	1,310	48

2. Band B

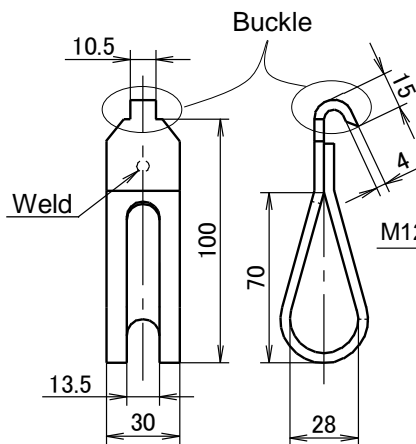

4. Double-end stud

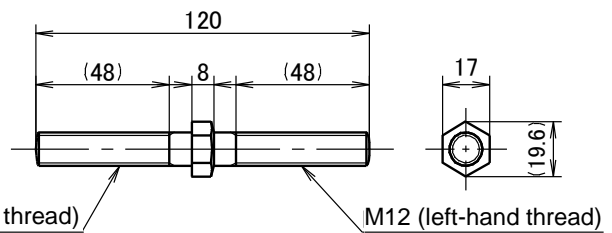

7. Anti-falling ring

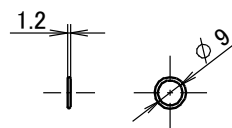

3. Collar

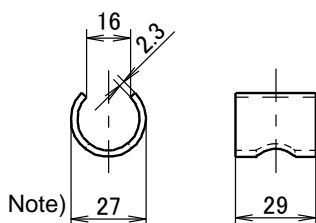

5. Square nut

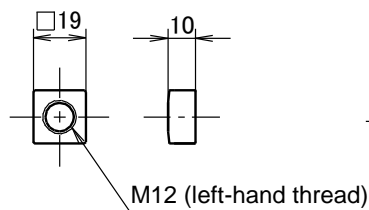

6. Square nut

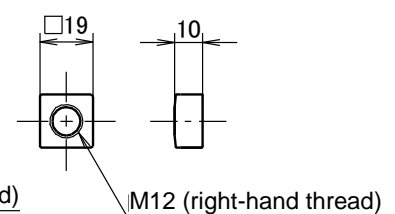

Note) Shall be able to be assembled to the head of band A.