

Situation of Storage and Treatment of Accumulated Water including Highly Concentrated Radioactive Materials at Fukushima Daiichi Nuclear Power Station (268th Release)

September 2, 2016

Tokyo Electric Power Company Holdings, Inc.

1. Introduction

This document is to report the following matters in accordance with the instruction of “Installment of treatment facility and storing facility of water including highly concentrated radioactive materials at Fukushima Daiichi Nuclear Power Station of the Tokyo Electric Power Company (Instruction) “(NISA No. 6, June 8, 2011), dated on June 9, 2011.

<Instruction>

TEPCO should report to NISA the situation of storing and treatment of the contaminated water in the Power Station and the future forecast based upon the current situation has to be reported to NISA as soon as the treatment facility starts its operation. Also, subsequently, continued report has to be submitted to NISA once a week until the treatment of the accumulated water in the Central Radioactive Waste Treatment Facility is completed.

2. Situation of storing and treatment of accumulated water in the building (actual record)

Stored amounts in each unit building (Units 1 to 4 (including condensers and trenches)) and stored and treated amounts, and other related data in the Accumulated Water Storing Facility as of September 1, 2016 are shown in the Attachment -1.

3. Forecast of storing and treatment

(1) Short term forecast

Water transfer is planned so that the levels of the accumulated water in Units 1 and 2 and Units 3 and 4 building will be maintained around at the level of OP. 3,000, based on the stored amount in the Accumulated Water Storing Facilities and the operating situation of the radioactive material treatment equipment. Water is transferred to the Process Main Building and/or High Temperature Incinerator Building as Accumulated Water Storing Facilities.

Treatment is implemented considering the state of storage and transfer of Accumulated Water Storing Facilities.

We assume stored amounts in each unit building (Units 1 to 4 (including condenser and trench)), and stored and treated amounts, and other related data in the Accumulated Water Storing

Facilities as of September 8, 2016, as shown in Attachment -2.

(2) Middle term forecast

Regarding accumulated water in Units 1 and 2 buildings and Units 3 and 4 buildings, from the viewpoint of reducing the risks of discharging to the ocean and leaking into the groundwater, it is necessary to keep enough capacity for the accumulated water in the building until its level reaches OP. 4,000 and to keep the accumulated water level lower than the groundwater level. On the other hand, based on the view of limiting inflow of underwater to buildings and reducing the amount of emerged accumulated water, we are planning to transfer accumulated water keeping its level in the building around OP. 3,000 considering water tank capacity.

As for accumulated water of the Process Main Building and the High Temperature Incinerator Building, we are planning to treat the accumulated water considering the situation of construction of middle and low level waste water tanks, the operation factor of the radioactive material treatment instruments and duration for maintenance.

We forecast stored amounts in each unit building (Units 1 to 4 (including condensers and trenches)), and storing and treatment situations in the Accumulated Water Storing Facilities for the next 3 months, as shown in Attachment -3.

Stored amounts in each building and the water storage equipment are forecasted to be unchanged in case transfer and treatment were implemented as scheduled without rain. However, it would be subject to change depending on the operation factor of the radioactive material treatment instruments and so on.

Also, the water treated at the radioactive material treatment equipment (fresh water and condensed salt water) can be stored in the middle and low level waste water tanks.

END

Storage and treatment of high level radioactive accumulated water (as of September 1, 2016)

Classification	
	High level radioactive water/ Waste, Concentrated waste liquid
	Treated water (saltwater)
	Treated water (concentrated saltwater), pipe removal
	Strontium-treated water
	Treated water (freshwater), pipe removal
	Treated water from Multi-nuclide Removal Facility
	Freshwater

Volume of water to be injected to Reactor (8/25-9/1)	Change from last report
① Filtrate water	-
② Treated water (freshwater)	2,187m ³ -11m ³
Cumulative treated water	718,203m ³

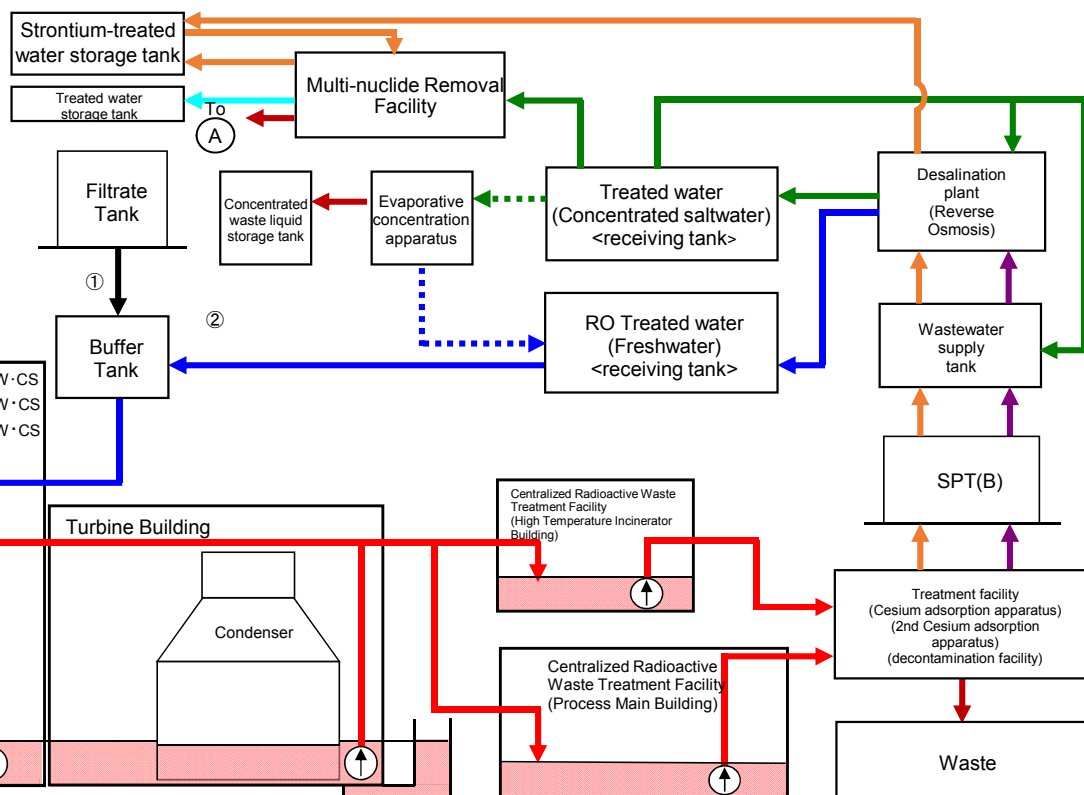

Storage volume ^{1,2}		Change from last report	Storage capacity ^{3,4}
Concentrated saltwater receiving tank*1	0m ³	-	-
Freshwater receiving tank	16,452m ³	+595m ³	18,900m ³
Concentrated waste liquid storage tank	9,189m ³	-12m ³	10,700m ³
Treated water storage tank	681,635m ³	+4,209m ³	690,500m ³
Strontium-treated water storage tank	188,681m ³	-1,738m ³	210,700m ³

Residual water ⁵		Change from last report	Storage capacity ³
Concentrated saltwater tank	Approx. 4,400m ³	No Change	Approx. 60,000m ³

Storage volume		Change from last report	Storage volume ³
Wastewater supply tank	684m ³	-5m ³	1,200m ³
SPT(B)	719m ³	-692m ³	3,100m ³

Chloride concentration	
Before/After Desalination	190ppm/<1ppm (Sampled on August 16)
Before/After Evaporative Concentration	-

Place of Sampling	Radioactivity concentration ⁶
Process Main Building	1.6E+07 Bq/L (Sampled on July 20)
Exit of cesium adsorption apparatus	1.7E+02 Bq/L (Sampled on July 20)
Exit of decontamination facility	-
High Temperature Incinerator Building	1.3E+07 Bq/L (Sampled on August 16)
Exit of second cesium adsorption apparatus	1.3E+03 Bq/L (Sampled on August 16)

Facility	Storage volume	Change from last report	Water level in T/B ^{*8}
Unit 1	Approx. 12,500m ³	+100m ³	T.P. 1,645 (O.P. 3,102)
Unit 2	Approx. 15,900m ³	-400m ³	T.P. 1,415 (O.P. 2,867)
Unit 3	Approx. 16,700m ³	-200m ³	T.P. 1,477 (O.P. 2,914)
Unit 4	Approx. 15,800m ³	No change	T.P. 1,375 (O.P. 2,814)
Total	Approx. 60,900m ³		

Storage Facility	Storage volume	Change from last report	Water level ^{*8}	Treated volume (8/25-9/1)	Cumulative treated volume	Waste produced		Change from last report	Storage capacity
						Sludge	Used vessels		
Process Main Building	Approx. 9,630m ³	+3,980m ³	T.P. +938 (O.P. 2,300)	Approx. 4,580m ³ ^{3,7}	Approx. 1,604,160m ³ ^{3,7}	Sludge	597m ³	No Change	700m ³ ³
High Temperature Incinerator Building	Approx. 3,700m ³	+70m ³	T.P. +808 (O.P. 2,254)			Used vessels	3,279 ⁹	+5m ³	6,239
Total	Approx. 13,330m ³								

¹ The figures of the data are treated as a reference, because water levels during water transfer are not stable.
² The figures of the storage volume do not include those of the following volumes that have accumulated from the bottom of the tanks to the height of so-called "down scale (DS)," where water gauges show 0%:
 Freshwater receiving tank (approx. 1,000m³), Concentrated waste liquid storage tank (approx. 100m³), Treated water storage tank (approx. 1,000m³), Strontium-treated water storage tank (approx. 3,000m³).
³ The figures of the data show the operational limits.
⁴ The figures of "Storage capacity" do not include those of the volumes that have accumulated from the bottom of the tanks to the height of so-called "down scale (DS)," where water gauges show 0%. However, each tank has the capacity that accommodates more than the storage volume that accumulates up to the height of "DS."
⁵ The figure of "Residual water" includes the one of the volumes that have accumulated from the bottom of the tanks to the height of so-called "down scale (DS)," where water gauges show 0%. The amount of the residual water of concentrated saltwater is calculated based on that of the water treated through the ALPS and other facilities.
⁶ The data shown here are those of Cs-137.
⁷ Total treated amount of Cesium adsorption apparatus and 2nd Cesium adsorption apparatus
 Breakdown of the treated amount: Cesium adsorption apparatus (0m³)
 2nd Cesium adsorption apparatus (4,580m³)
 Breakdown of the cumulative treated amount: Cesium adsorption apparatus (353,970m³)
 2nd Cesium adsorption apparatus (1,250,190m³)
⁸ The data of the water levels in the Reactor Buildings are the data as of 7 a.m., September 1.
⁹ Breakdown of the used vessels: Cesium adsorption apparatus (742)
 2nd Cesium adsorption apparatus (170)
 Others: Storage container (2,102), Treated column (9), Used vessel (191), Filters and so forth (65)

[Main operations that have been conducted during the period from August 25, 2016 (the previous announcement data) to September 1, 2016]
 - Water transfer from the Unit 1 Reactor Building to the High Temperature Incinerator Building and the Process Main Building was conducted whenever necessary.
 - Water transfer from the Unit 2 Turbine Building to the High Temperature Incinerator Building and the Process Main Building was conducted whenever necessary.
 - Water transfer from the Unit 2 Radioactive Waste Treatment Facility to the Process Main Building was conducted whenever necessary.
 - Water transfer from the Unit 3 Turbine Building to the High Temperature Incinerator Building and the Process Main Building was conducted whenever necessary.
 - Water transfer from the Unit 3 Radioactive Waste Treatment Facility to the Process Main Building was conducted whenever necessary.
 - On August 28, water transfer from the Unit 1 Turbine Building to the Unit 1 Radioactive Waste Treatment Facility was conducted.
 - From July 27, operations of the Cesium Adsorption Apparatus have been suspended.
 - Operations of the 2nd Cesium Adsorption Apparatus have been conducted; the availability factor is 55% (previously simulated: 60%).
 - Storage capacity of "treated water" increased as new storage tanks started operations.
 - Storage capacity of "concentrated saltwater" decreased as existing storage tanks finished operations.
 - Water transfer to the buildings (Units 1-4, the Process Main Building, the High Temperature Incinerator Building) was conducted whenever necessary due to the other work.

Storage and treatment of high level radioactive accumulated water (as of September 8, 2016)

Classification	
	High level radioactive water/Waste, Concentrated waste liquid
	Treated water (saltwater)
	Treated water (concentrated saltwater) / Removal of piping
	Strontium-treated water
	Treated water (freshwater) / Removal of piping
	Treated water from Multi-nuclide Removal Equipment
	Freshwater

Volume of water to be injected to Reactor (9/1-9/8)	Change from last report
① Filtrate water	-
② Treated water (freshwater)	+81m ³
Cumulative treated water	720,471m ³

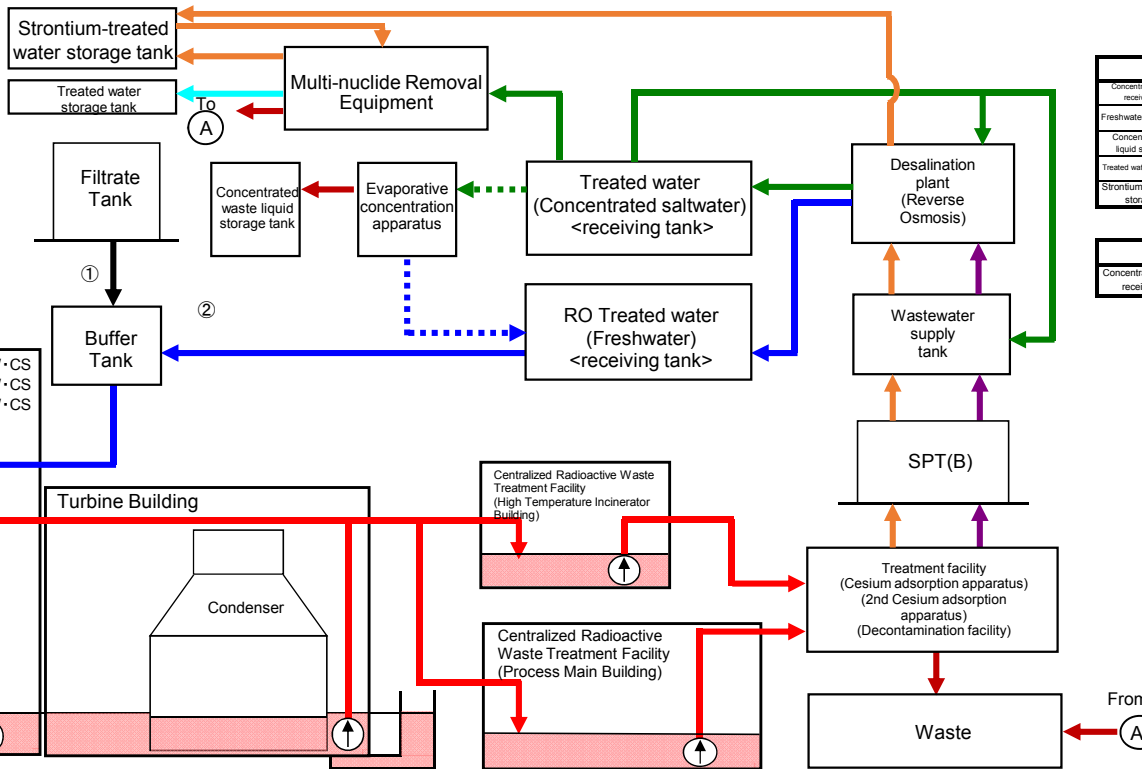
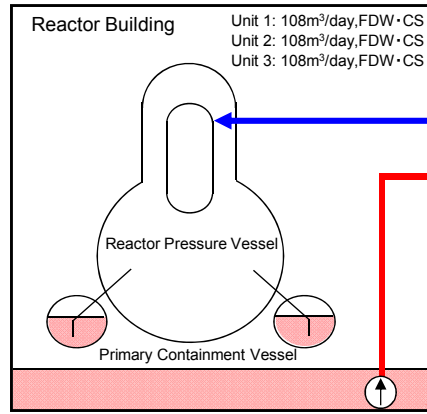

Storage volume ¹	Change from last report	Storage capacity ^{2,3}
Concentrated saltwater receiving tank ¹	0m ³	-
Freshwater receiving tank	16,371m ³	-81m ³
Concentrated waste liquid storage tank	9,189m ³	No Change
Treated water storage tank ⁴	686,362m ³	+4,727m ³
Strontium-treated water storage tank	187,907m ³	-774m ³

Residual water ⁴	Change from last report	Storage capacity ^{2,3}
Concentrated saltwater receiving tank	Approx. 3,700m ³	-700m ³
		Approx. 60,000m ³

Facility	Storage volume	Change from last report	Water level in T/B
Unit 1	Approx. 12,700m ³	+200m ³	T.P. 1,593 (O.P. 3,045) (Unit 2 T/B)
Unit 2	Approx. 16,900m ³	+1,000m ³	
Unit 3	Approx. 16,900m ³	+200m ³	T.P. 1,544 (O.P. 2,981) (Unit 3 T/B)
Unit 4	Approx. 16,300m ³	+500m ³	
Total	Approx. 62,800m ³		

Storage Facility	Storage volume	Change from last report	Water level	Treated volume (9/1-9/8)	Cumulative treated volume	Waste produced		Change from last report	Storage capacity
						Sludge	Used vessels		
Process Main Building	Approx. 12,160m ³	+2,530m ³	T.P. +1,666 (O.P. 3,028)	Approx. 5,040m ³⁻⁵	Approx. 1,609,200m ³⁻⁵	597m ³	700m ³⁻²	No Change	6,239
High Temperature Incinerator Building	Approx. 2,870m ³	-830m ³	T.P. +130 (O.P. 1,576)			3,294 ⁶			
Total	Approx. 15,030m ³								

[Main operations that are planned to be conducted during the period from September 1, 2016 to September 8, 2016.]

- Water transfer from the Unit 1 Reactor Building to the High Temperature Incinerator Building and the Process Main Building will be conducted whenever necessary.
- Water transfer from the Unit 2 Turbine Building to the High Temperature Incinerator Building and the Process Main Building will be conducted whenever necessary.
- Water transfer from the Unit 2 Radioactive Waste Treatment Facility to the Process Main Building will be conducted whenever necessary.
- Water transfer from the Unit 3 Turbine Building to the High Temperature Incinerator Building and the Process Main Building will be conducted whenever necessary.
- Water transfer from the Unit 3 Radioactive Waste Treatment Facility to the Process Main Building will be conducted whenever necessary.
- Water transfer from the Unit 1 Turbine Building to the Unit 1 Radioactive Waste Treatment Facility will be conducted.
- Operations of the Cesium Adsorption Apparatus will continue to be suspended.
- Operations of the 2nd Cesium Adsorption Apparatus will be conducted (assumed availability factor 60%).
- Storage capacity of "treated water" will increase as new storage tanks start operations.

¹ The figures of "Storage volume" do not include those of the volumes that have accumulated from the bottom of the tanks to the height of so-called "down scale (DS)," where water gauges show 0%.

² The figures of the data show the operational limits.

³ The figures of "Storage capacity" do not include those of the volumes that have accumulated from the bottom of the tanks to the height of so-called "down scale (DS)," where water gauges show 0%. However, each tank has the capacity that accommodates more than the storage volume that accumulates up to the height of "DS."

⁴ The figure of "Residual water" includes the one of the volumes that have accumulated from the bottom of the tanks to the height of so-called "down scale (DS)," where water gauges show 0%. The amount of the residual water of concentrated saltwater is calculated based on that of the water treated through the ALPS and other facilities.

⁵ Total treated amount of Cesium adsorption apparatus and 2nd Cesium adsorption apparatus Breakdown of the treated amount: Cesium adsorption apparatus (0m³)
2nd Cesium adsorption apparatus (5,040m³)
Breakdown of the cumulative treated amount: Cesium adsorption apparatus (353,970m³)
2nd Cesium adsorption apparatus (1,255,230m³)

⁶ Breakdown of the used vessels: Cesium adsorption apparatus (742)
2nd Cesium adsorption apparatus (174)
Others: Storage container (2,112), Treated column (9), Used vessels (192), Filters and so forth (65)

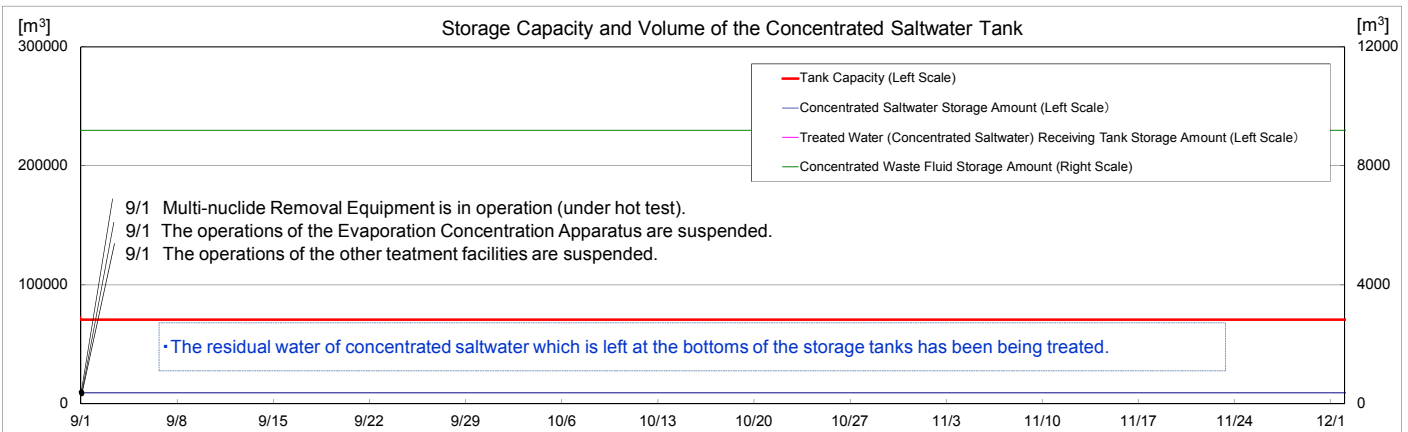
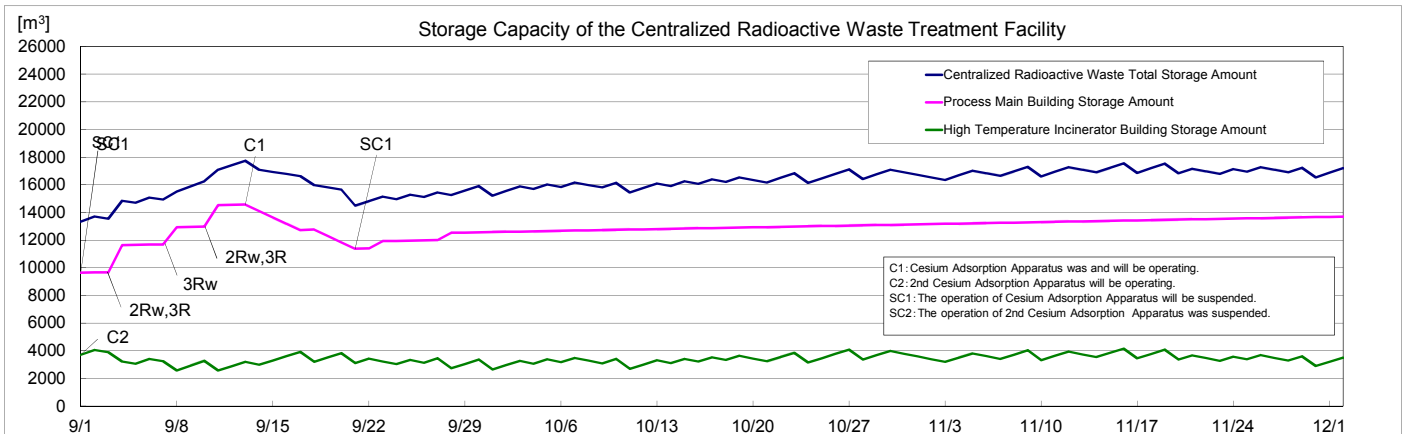
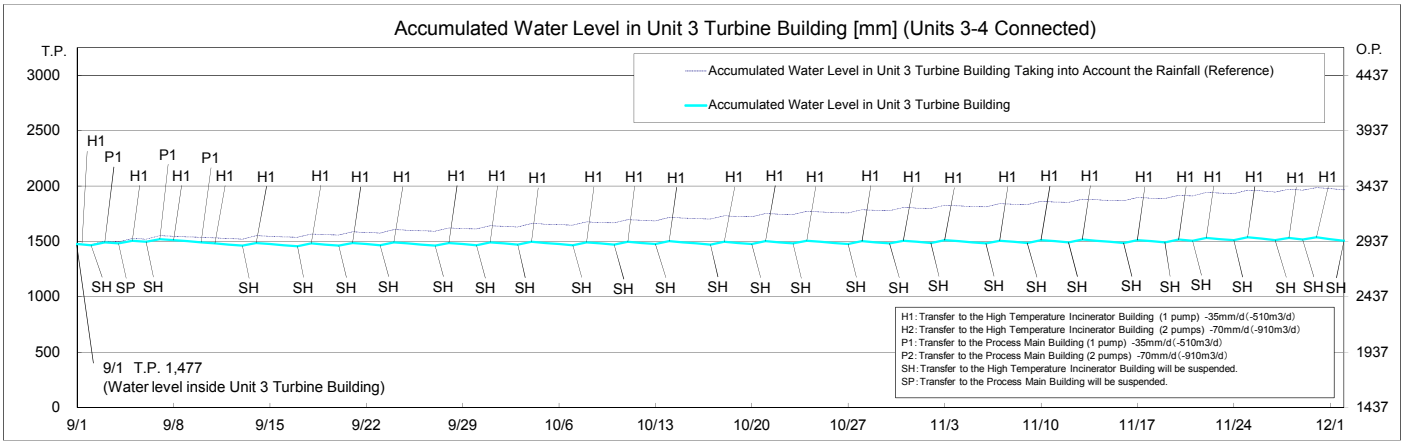
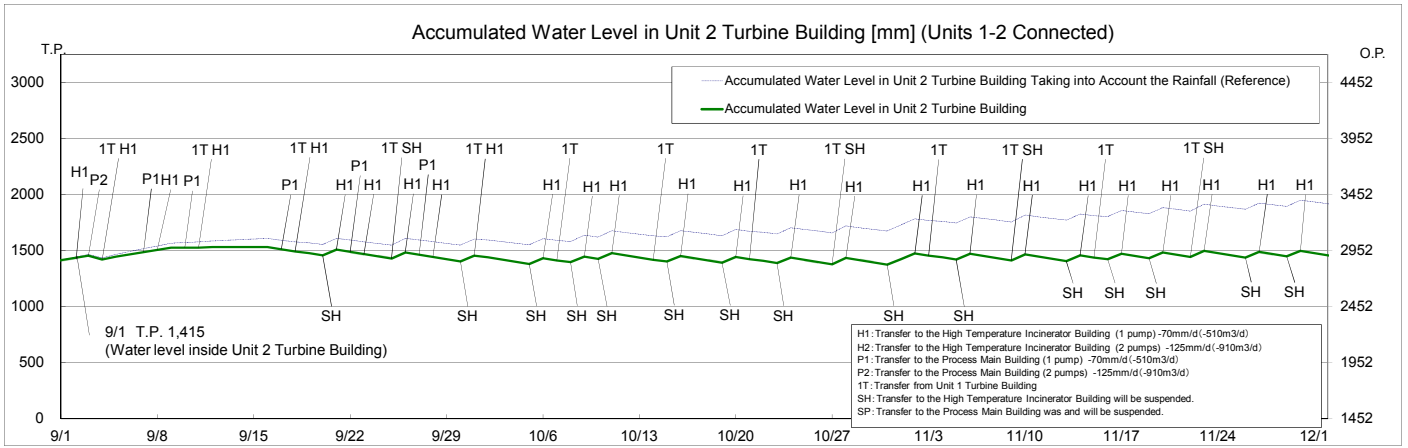

Note

- The amount of water treated through the 2nd Cesium Adsorption Apparatus is estimated to be 780m³/d (Subject to change depending on the factors such as the levels of water accumulated in T/Bs).
- "Accumulated Water Levels in Unit 2 and 3 T/Bs" are simulated water levels in consideration of the change of the water levels caused by recent rainfall, inflow of groundwater, etc. in the surrounding areas of the Fukushima Daiichi Nuclear Power Station.
- "Accumulated Water Levels in Unit 2 and 3 T/Bs Taking into Account the Rainfall" are simulated water levels which are calculated by adding to the accumulated water amounts which are assumed to increase at the rate of 5mm a day when the surrounding areas of the Fukushima Daiichi Nuclear Power Station have the rainfall equal to the average amount of rain which fell for three months from August to October in 2008 to 2010.