

Status of heat removal in the isolation condenser at Unit-1

1. Introduction

At Unit-1 the reactor was being cooled and its pressure was under control after the earthquake by intermittent operation of the isolation condenser (IC; a schematic drawing is shown in Figure 1). Immediately before the station blackout due to tsunami, the IC operation was temporarily in a halted situation. After the station blackout, the shift operator noticed in the Main Control Room the indicator lamps were "ON" indicating "CLOSURE" of the IC (Channel A) isolation valves (MO-2A, MO-3A) outside the containment vessel. The operator attempted to open the valves at 18:18 on March 11th and confirmed that steam was being discharged from the reactor building based on witnessing it and hearing its sounds behind the building. But the amount of steam produced was limited and steam generation ceased after a while. The operator, having been concerned about depletion of the IC tank water inventory, closed the return line isolation valve (MO-3A).

In general the IC cooling capacity is considered to deteriorate, when non-condensable hydrogen gas is generated due to water-zirconium reactions, by the mixing of hydrogen gas into the cooling lines. From the analysis done so far, the reactor water level was kept at the level just below the top of active fuel (TAF) before 18:18 and a large amount of hydrogen might not have been generated. But hydrogen gas might have been also generated by radiolysis. It is necessary to clarify to what extent the IC heat removal capability deteriorated at Unit-1.

According to the IC water level surveys conducted after the accident, the tank water level of Channel A was 65% (vs. normal level at 80%) as of October 18th, 2011, showing there was sufficient water inventory at the time of IC shutdown. If the return line isolation valve (MO-3A) had NOT been closed at 18:25 on March 11th, the IC could have continued reactor cooling. From these considerations, two issues are examined: Why did the amount of steam generation decline and cease after a while after the IC Channel A isolation valves had been opened (Unit-1/Issue-1)? What could be the possible influence on the accident progression if the IC Channel A isolation valve outside the containment vessel had been kept open (Unit-1/Issue-2)?

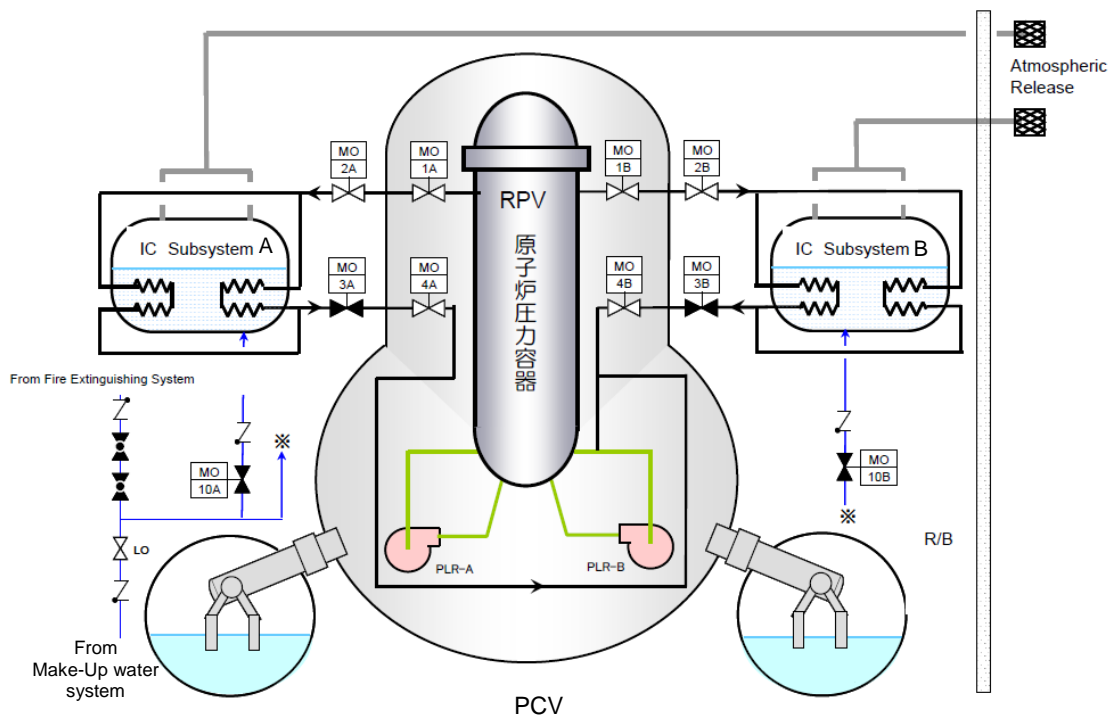

Figure 1 Schematic diagram of isolation condenser system

2. Evaluation of heat removal capability

MAAP5.01 simulated the IC system and analyzed the accident progression taking into account the IC operation history from the reactor scram to the station blackout. The results are presented as Attachment 3 along with Progress Report 2.

After the station blackout, the IC might have been unable to keep its heat removal capability due to the unexpected non-condensable gas trapped in the IC heat transfer tubes. The earlier analysis (Attachment 3) therefore assumed that the IC had not been operable regardless of the IC valve operations after 18:18 on March 11th.

In the current analysis, the IC was assumed to start up upon the valve opening operation of IC Channel A at 18:18 and further assumed to continue working after the valve closing operation at 18:25 (this is designated as the IC working case). All other conditions for analysis were set the same as in the earlier analysis. Also concerning the gaseous phase leaks from the containment vessel, the reactor building closed cooling water system (RCW) was assumed to have been damaged, allowing the leaks, upon the RPV being damaged, as was assumed in the earlier analysis (Attachment 3). Table 1 summarizes the IC operating conditions in the earlier analysis and the current IC working case.

Table 1 IC operating conditions

Time on March 11 th	Incident	Earlier analysis	IC working case
14:46	Earthquake		
14:48	Reactor scrammed		
14:52	IC(A)(B) started up automatically	In operation	
15:03	IC(A) stopped	Not in operation	
15:03	IC(B) stopped	Not in operation	
15:17	IC(A) restarted	In operation	
15:19	IC(A) stopped	Not in operation	
15:24	IC(A) restarted	In operation	
15:26	IC(A) stopped	Not in operation	
15:32	IC(A) restarted	In operation	
15:34	IC(A) stopped	Not in operation	
15:37	Station blackout		
18:18	IC(A) valves 2A,3A opened	Not in operation	In operation
18:25	IC(A) valve 3A closed	Not in operation	In operation
21:30	IC(A) valve3A opened	Not in operation	In operation

3. Examination of the accident progression from the scram to the station blackout

From the scram to the station blackout, there are no differences between the earlier analysis and the IC working case. Figure 2 compares the measured reactor pressures recorded on the transient recorder and the MAAP results. The analysis results show bigger changes compared with the measured data but both are more or less consistent. The IC system is driven by the pressure difference between the values at its inlet (reactor pressure) and outlet (after pressure drop due to heat removal and condensation of steam), i.e., this pressure difference provides the driving force to statically let the steam flow in the IC tubes. As a result, while the IC is working with its valves opened, the steam is cooled and condenses in the IC, and then the condensed water returns to the reactor and re-evaporates by absorbing decay heat. By repeating this cycle, heat energy is transferred to the IC shell side and the reactor pressure decreases gradually. Along with the decreasing reactor pressure, the steam flow to the IC tubes decreases and the amounts of steam supplied and heat removed decrease, as seen in Figure 3 (amount of steam supplied to IC) and in Figure 4 (amount of heat removed), both by MAAP analysis.

The IC shell side receives heat from the reactor and its water temperatures increase. Figure 5 shows the observed shell side water temperatures (chart readings) and MAAP

results. The water temperature increase on the shell side is in agreement between measurement and analysis. That means the IC heat removal capabilities are fairly well simulated in the analysis.

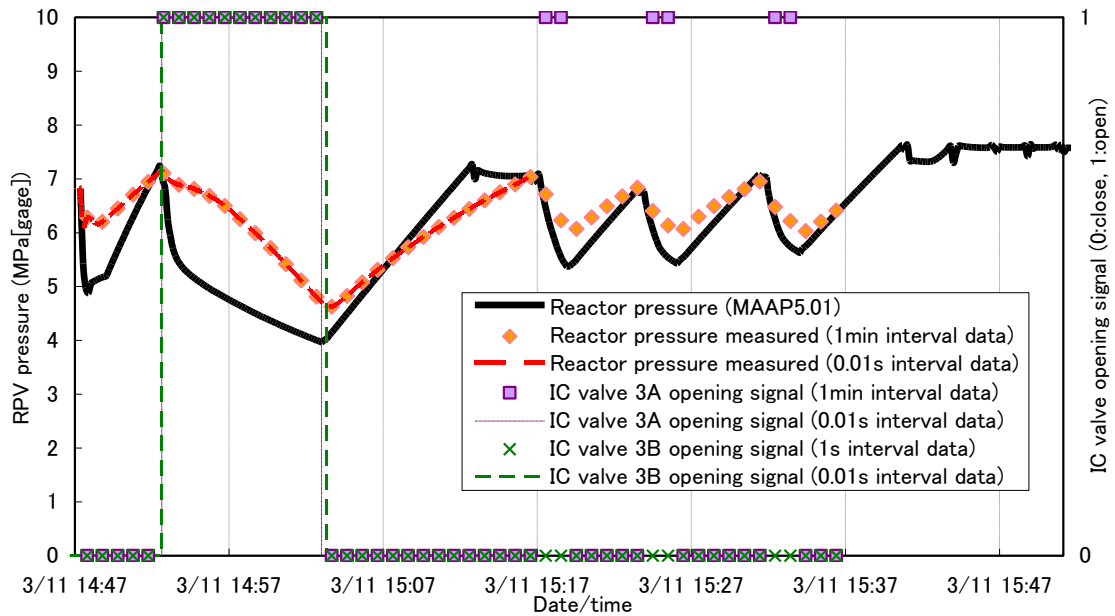

Figure 2 Reactor pressures (observed data from the transient recorder and analysis results) and the timings of IC valves opening

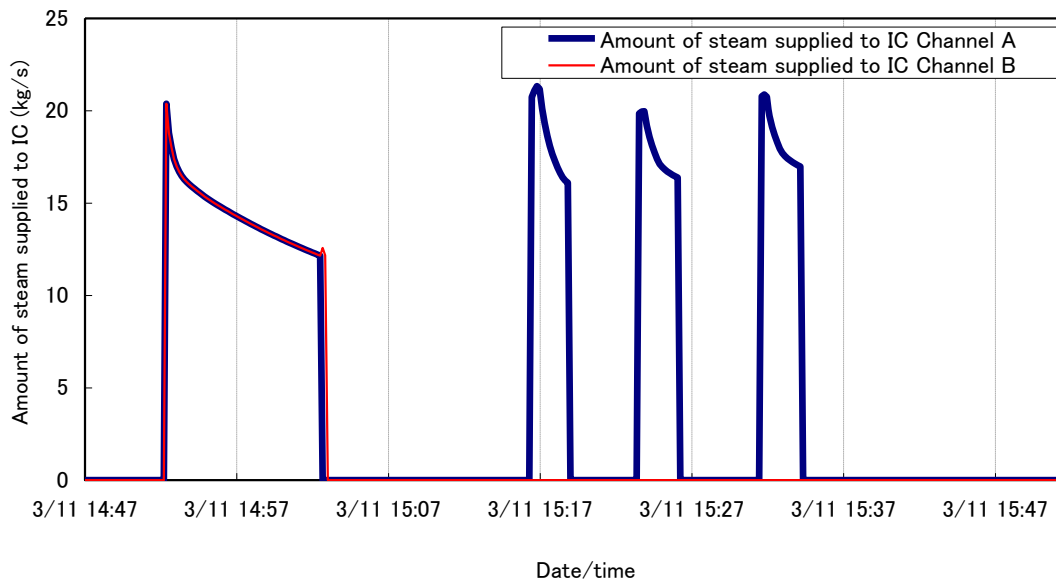

Figure 3 Amount of steam supplied to IC (MAAP analysis)

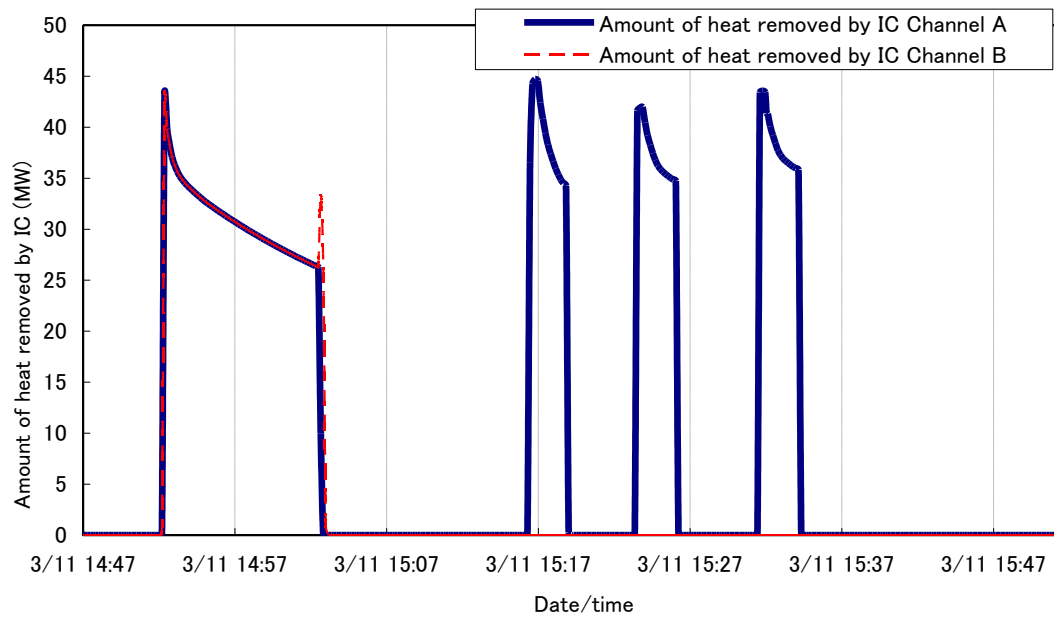

Figure 4 Amount of heat removed by IC (MAAP analysis)

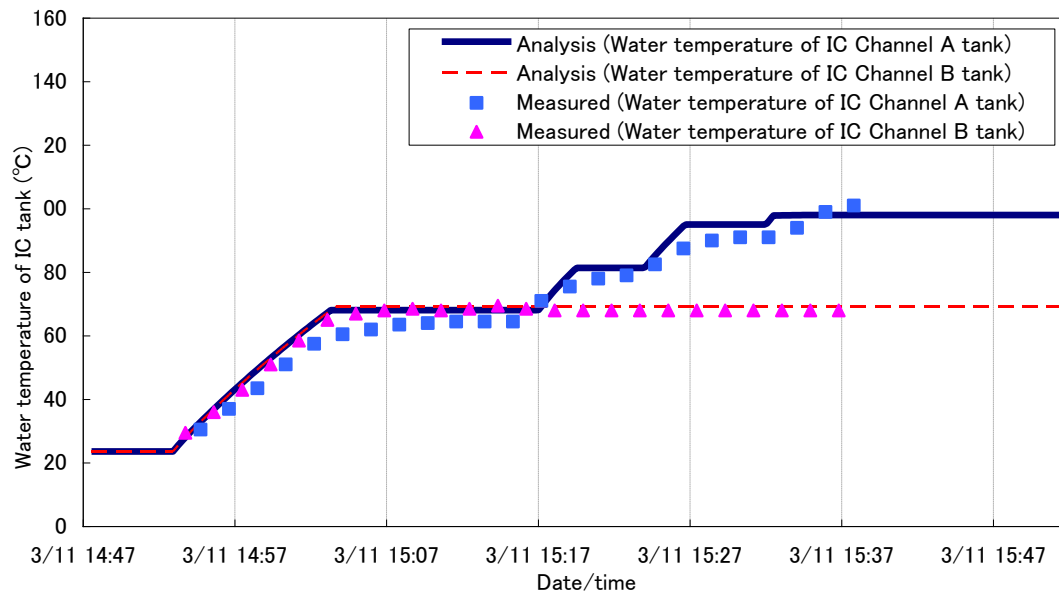

Figure 5 IC shell side temperatures (measured (chart readings) and MAAP analysis)

4. Evaluation of the accident progression after the station blackout

Concerning the IC operating conditions after the station blackout, the closing operation of IC Channel A isolation valve at 18:25 was ignored in the IC working case, as explained in Section 2 above, and the IC was assumed to have continued its operation. Figures 6 through 12 present the results of the IC working case and the earlier analysis after 18:18, when the IC Channel A isolation valve was opened: Figure 6 Reactor water level changes; Figure 7 Reactor pressure changes; Figure 8 Containment vessel pressure changes; Figure 9 Core temperature changes; Figure 10 Gas temperature changes in the reactor vessel; Figure 11 Containment vessel temperature changes; and Figure 12 Amount of hydrogen generated.

Upon the IC startup at 18:18, the IC starts removing heat and the reactor pressure decreases drastically. It should be noted that fuel temperatures are in an increasing trend, because, according to the MAAP analysis, the reactor water level had cut the TAF level before 18:18 when the IC started up and the fuel began to be uncovered. The IC can remove the heat, but it does not inject external water to the reactor and it cannot restore the level to flood the core. Current MAAP analysis shows that the reactor water and its evaporation are not enough to prevent fuel temperatures from increasing. As the fuel temperatures increase, the amount of hydrogen gas generated by water-zirconium reactions sharply increases, this hydrogen gas trapped in the IC tubes blocks the steam flow, and thus the IC heat removal capacity is quickly deteriorated and eventually lost. The reactor pressure increases rapidly thereafter and shows the similar accident progression to the earlier analysis.

No considerations were given to water radiolysis in the current MAAP analysis. In the IC working case MAAP gives the results that the heat removal by IC startup at 18:18 decreases very rapidly after around 19:00 when the water-zirconium reactions start generating hydrogen gas and that it drops to almost zero at around 19:05 when about 20kg of hydrogen is generated. The amount of non-condensable gas (hydrogen, oxygen) due to water radiolysis is proportional to the decay heat. The amount of non-condensable gas from the scram to 19:05 is about 1.5kg, which is less than 10% of the amount of hydrogen generated by the water-zirconium reactions. It should also be noted that, upon the SRV activation, the non-condensable gas is also discharged from the RPV together with steam, thus further decreasing its amount remaining in the RPV. In conclusion, it is considered that the influence of water radiolysis on the IC heat removal capability is very limited and the heat removal capability deterioration is mainly due to water-zirconium reactions.

When comparing the results of the IC working case and the earlier analysis, it can be noted that damage of core support plate and RPV is delayed in the IC working case. This

means the heat removal by the IC after 18:18 could delay the accident progression but it was not enough to stop the accident progression itself.

Damage of the main steam line flange gaskets takes place earlier in the IC working case than in the earlier analysis. This is because the RPV atmosphere temperature was just short of 450 deg C in the earlier analysis at which temperature the flange gaskets were assumed to be damaged. This difference is considered to come from the difference in the conditions in the reactor (for example, the reactor water level or fuel temperatures when the in-core instrumentation dry tubes were damaged) or the difference in the amount of water-zirconium reaction products in the analysis models. Certainly, in the two analyses there is a difference in the timing of damage of main steam line flange gaskets and the ensuing reactor pressure decrease, but the results in both are essentially the same.

Concerning the gas temperatures in the RPV, the IC working case gives generally higher values. This is because, in the IC working case, the steam condensed in the IC can evaporate again when returned to the reactor, and thus water-zirconium reactions are considered to further continue due to this newly generated steam. But still, there is no big difference in the timing for the reactor water level to cut the BAF level, when steam generation ceased. Thus, only a small difference remains in the accident progression from the earlier analysis.

Figure 13 shows the heat removal by the IC (Channel A) and the non-condensable gas partial pressure, while Figure 14 gives the water inventory in the IC tank. The IC heat removal slightly recovers at the timings of the in-core instrumentation dry tubes damage, main steam line flange gaskets damage and reactor pressure decrease after the core support plate damage. This comes from the analytical model in which part of the hydrogen trapped in the IC returned to the RPV, but it is not certain whether such hydrogen return flow to the RPV can physically take place. Regardless of whether hydrogen gas returned to the RPV or not, the amount of water in the Channel A tank consumed for cooling is limited and the amount of water consumed is only about 30 to 40%, according to the analysis.

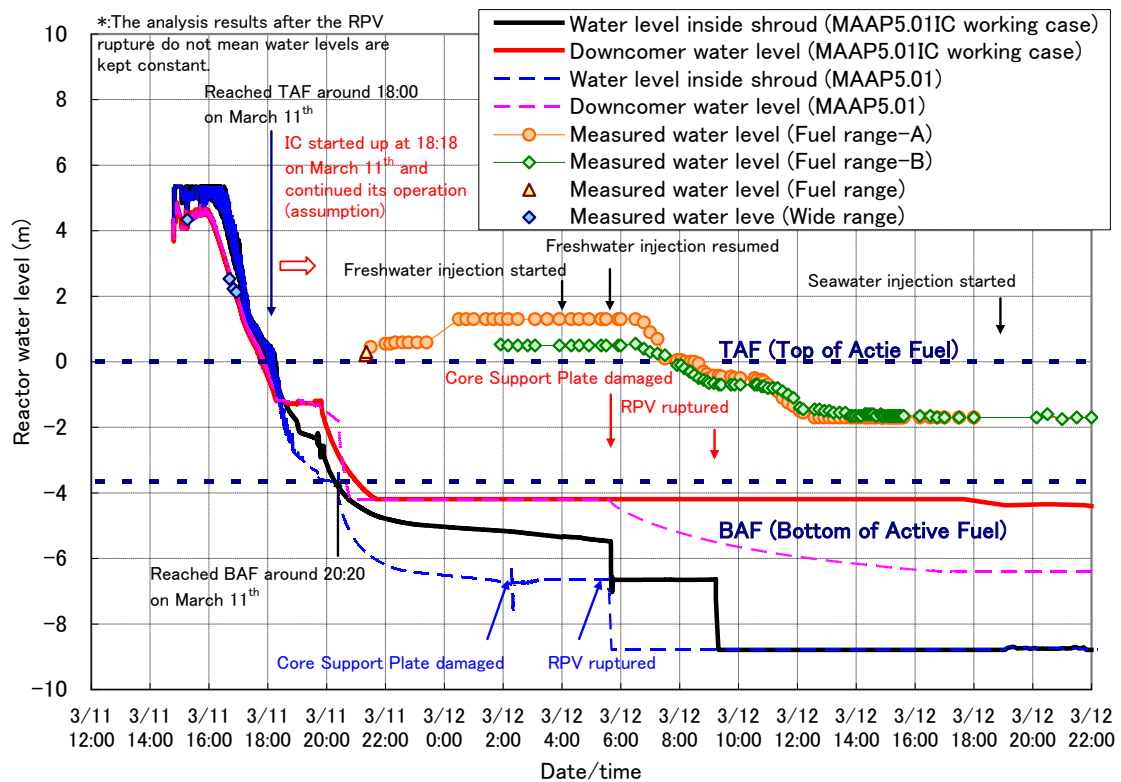

Figure 6 Reactor water level changes (IC working case (red) vs. earlier analysis (blue))

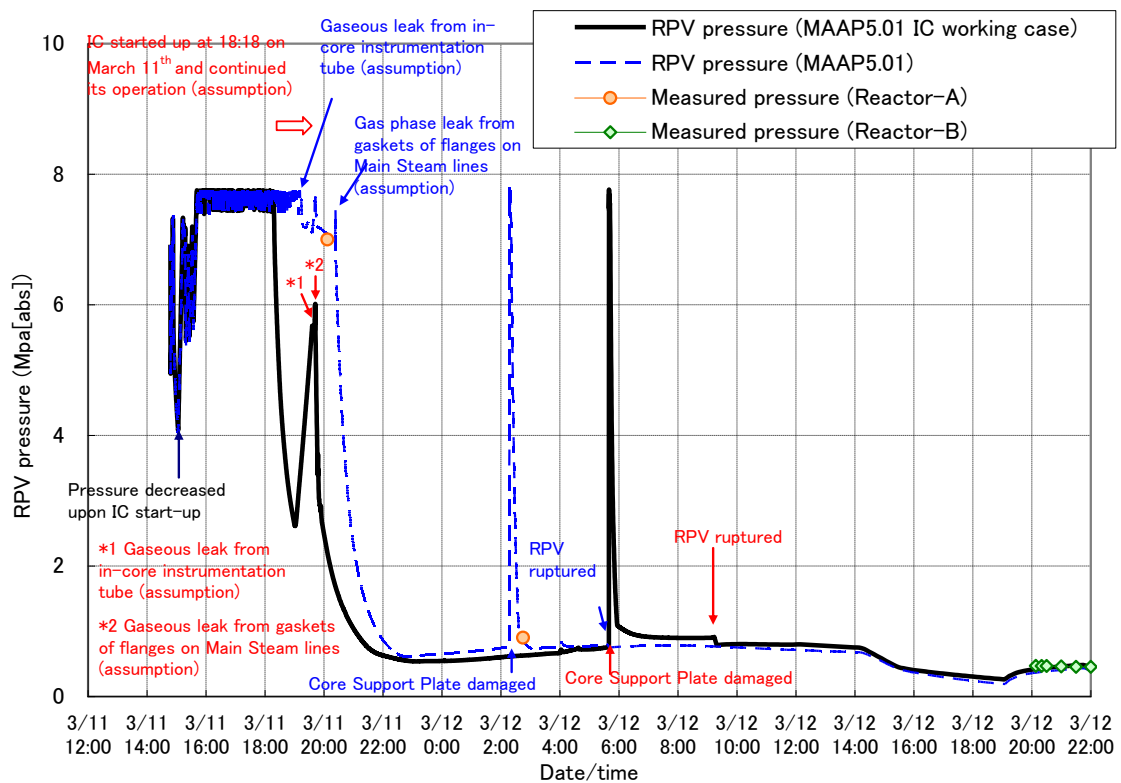

Figure 7 Reactor pressure changes (IC working case (red) vs. earlier analysis (blue))

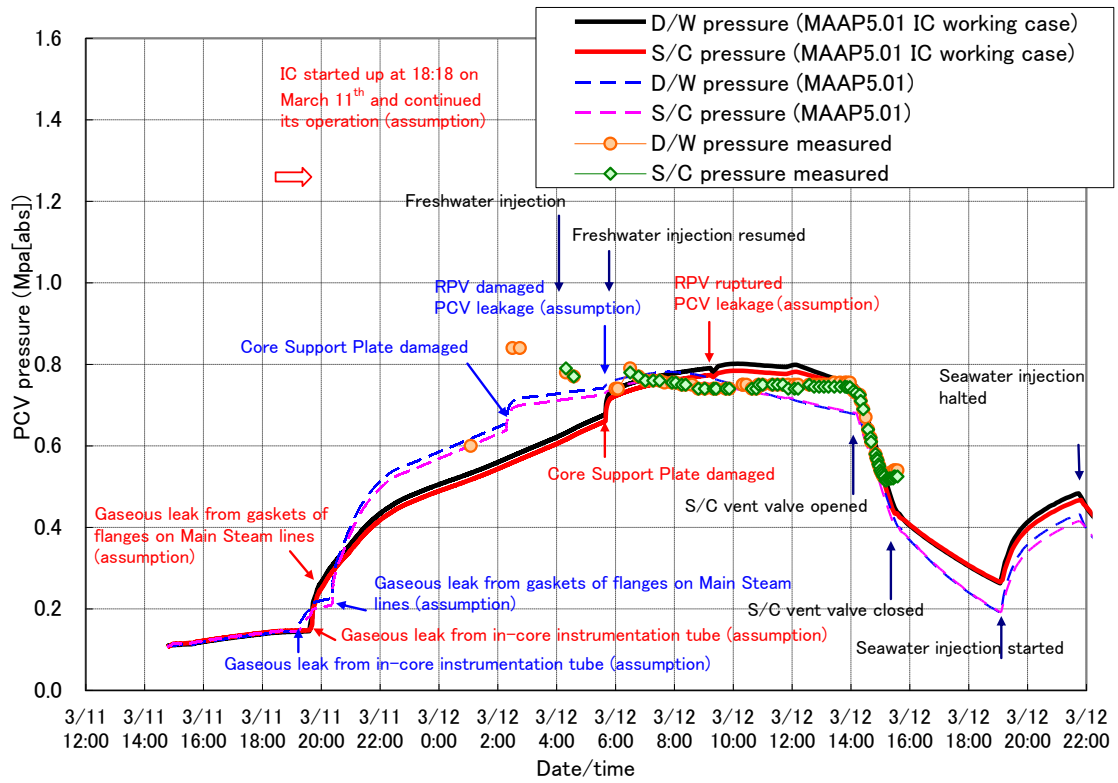

Figure 8 PCV pressure changes (IC working case (red) vs. earlier analysis (blue))

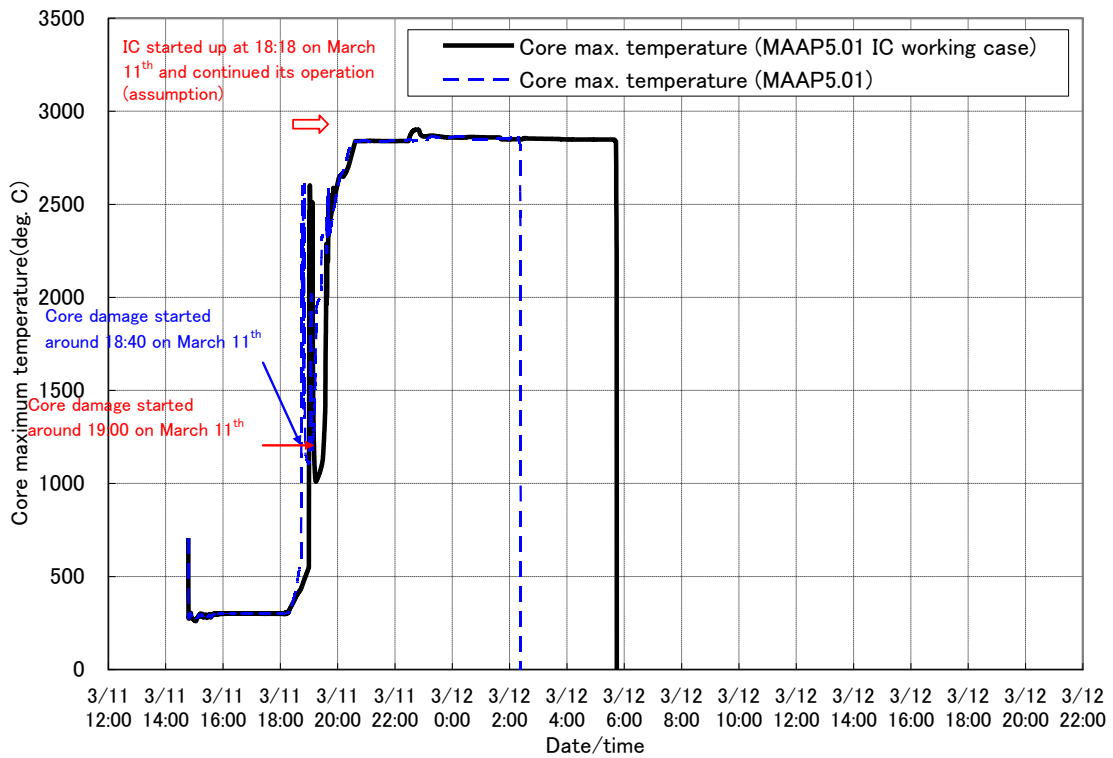

Figure 9 Core temperature changes (IC working case (red) vs. earlier analysis (blue))

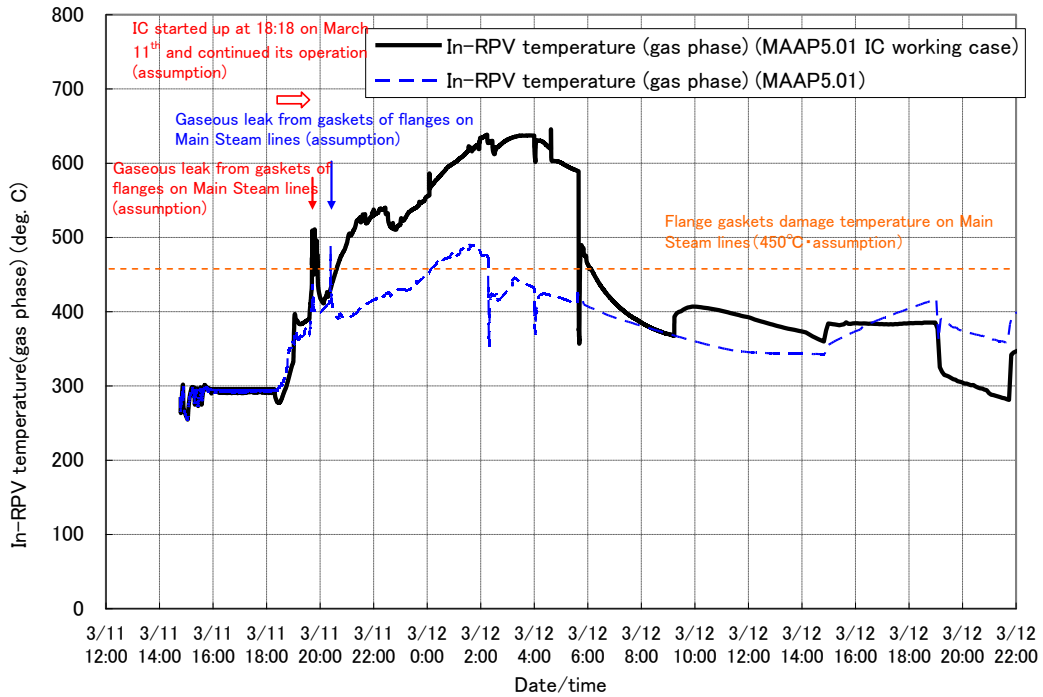

Figure 10 Gaseous temperature changes in RPV
(IC working case (red) vs. earlier analysis (blue))

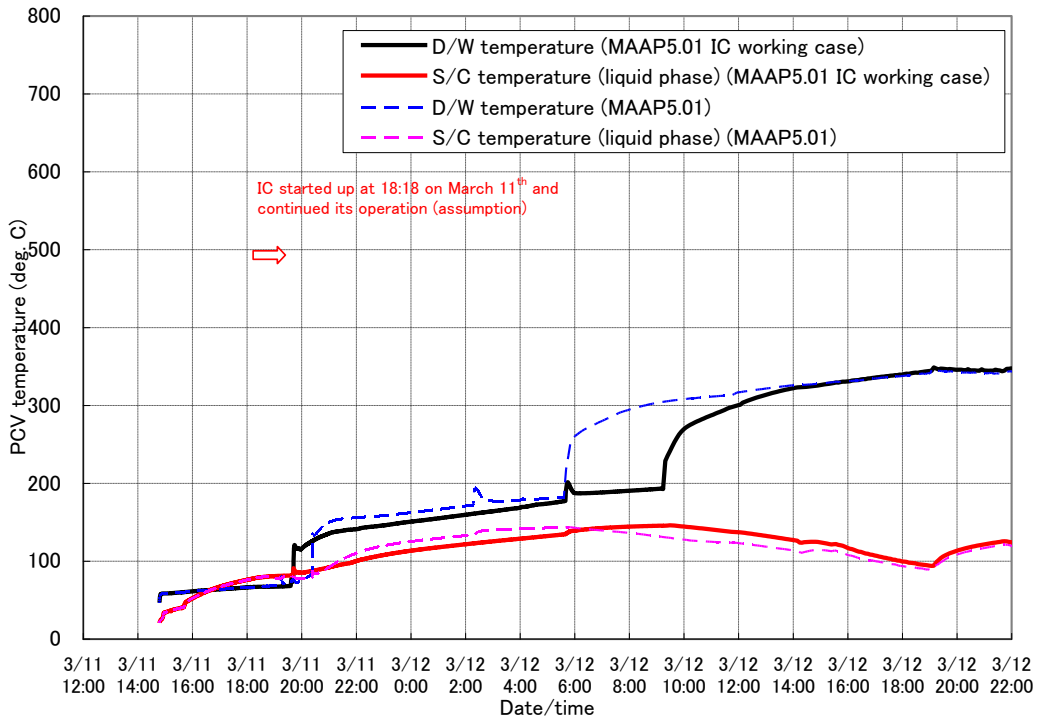

Figure 11 PCV temperature changes
(IC working case (red) versus earlier analysis (blue))

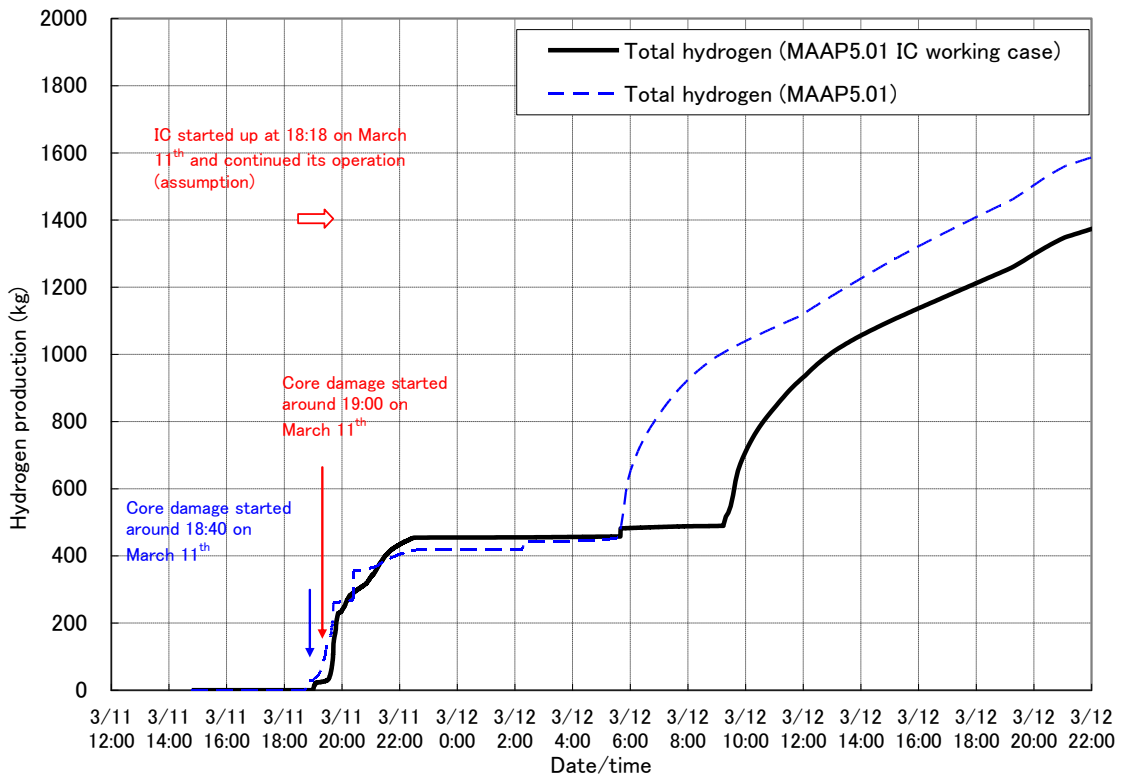

Figure 12 Hydrogen gas generation (IC working case (red) vs. earlier analysis (blue))

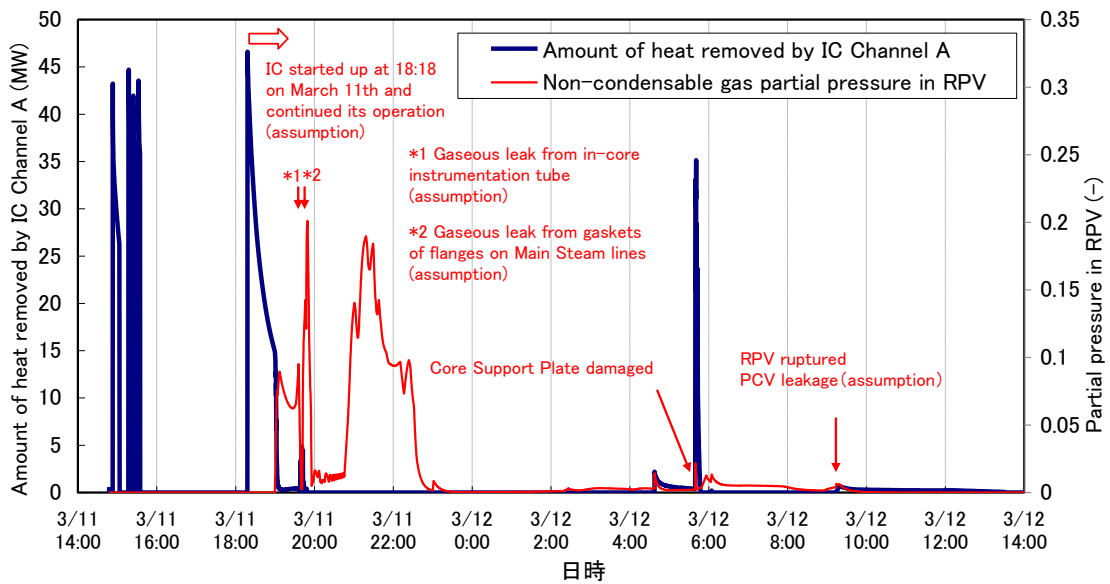

Figure 13 Amount of heat removed by IC Channel A and non-condensable gas partial pressure in RPV (IC working case)

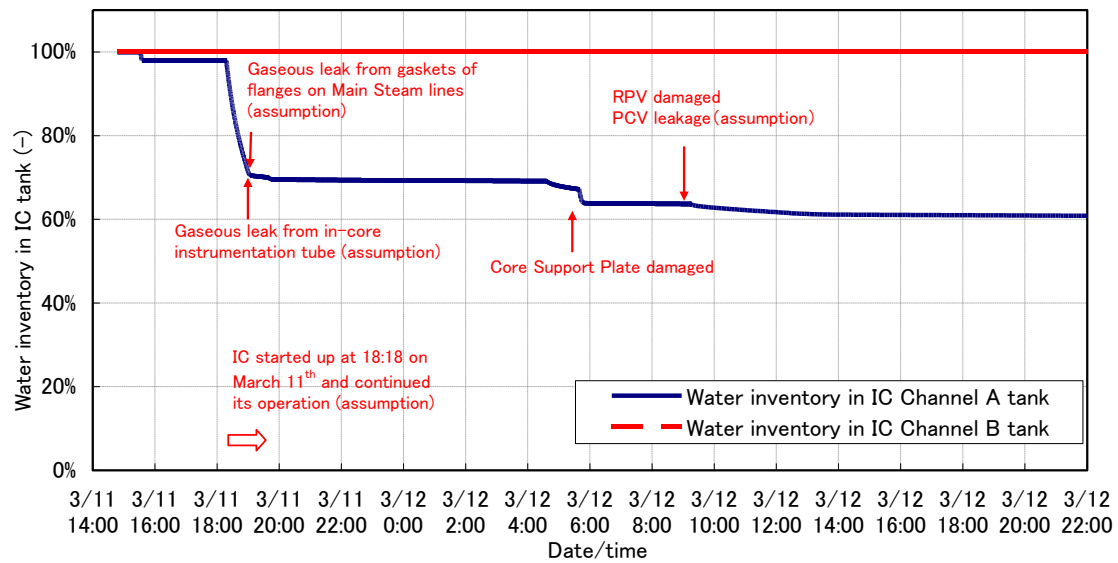

Figure 14 Amount of water inventory in IC tanks

5. Conclusion

The accident progression was examined for the case in which the IC was assumed to have remained operable beyond 18:25 when the IC had been actually deactivated after being activated at 18:18. The analysis results showed that, even if the IC had continued its operation, the hydrogen gas generated by water-zirconium reactions would have trapped in the IC tubes and deteriorated their heat removal capability eventually to null. In the IC working case assuming continued IC operation, the timing of RPV damage could be delayed, but no big difference in the accident progression could have taken place from the actual situation of Unit-1 to date.