

Report on the Investigation and Examination of
Unconfirmed/Unclear Matters
on the Development Mechanism of the Fukushima Nuclear Accident
Progress Report No.3

May 20, 2015

Tokyo Electric Power Company, Inc.

Table of Contents

■ Overview

1. Overview of the Fukushima Nuclear Accident	P 3
2. Positioning of this report	P 4
3. Investigation/Deliberation History	P 5
4. Progress made in the study of ten high-priority issues	P 6
5. Main points of the third progress report	P 7
6. Sharing insights and engaging in discussion with researchers from overseas	P 8

■ Matters studied

Overview of the third progress report	P10
1. Success or failure of Unit 2 containment vessel venting	P11
2. Regarding the dose rate increase seen around March 20 th	P17
3. Unit 1 measurement data and accident development assumptions made based on past analysis results	P23
4. Explanation on Unit 2 CAMS measurement data	P30
Terminology	P33

Report on the Results of the Examination and Review of
Unconfirmed/Unclear Matters

Progress Report No.3

Overview

1. Overview of the Fukushima Nuclear Accident

To date, TEPCO has compiled the following documents to summarize the Fukushima Nuclear Accident:

Fukushima Nuclear Accident Investigation Report

(Provides details on the facts related to conditions before and after the Fukushima Nuclear Accident)

Nuclear Safety Reform Plan

(Analyzes organizational causes that served as a backdrop for the accident, as well technical causes of the accident)

- ✓ Elucidated the root causes of the Fukushima Nuclear Accident
→Kashiwazaki-Kariwa NPS: Implemented safety countermeasures to prevent the occurrence of a severe accident
- ✓ TEPCO compliance with new safety regulations
→Nuclear Regulation Authority: Each measure discussed and confirmed at review meetings.

2. Positioning of this report

Accident root causes
(clarified)

Accident investigations to date have made it clear that the accident occurred because of a widespread loss of safety function caused by the tsunami that occurred after all external power had been cut off by the earthquake, and that escalation of the accident thereafter was not able to be stopped due to the lack of advanced accident prevention preparation.

After reviewing the details of various accident investigations conducted by other agencies and organizations, including TEPCO, the Nuclear Regulatory Agency's accident analysis review committee determined that the primary causes of the accident are the same as those above determined by TEPCO.

⇒The Kashiwazaki-Kariwa NPS has implemented safety countermeasures based on these results

Efforts to ensure that an accident like the Fukushima Daiichi Nuclear Accident never occurs again
Scope covered by the accident investigation report and the nuclear safety reform plan

Detailed accident development mechanism

Understanding the **unsolved issues of details of how the incident developed after the initial accident** is not only the responsibility of the parties involved in the accident but also important in order to:

- **predict the state of field debris and accumulate knowledge required for decommissioning**
- **provide knowledge for contributing to the improvement of precision of accident simulation models used by countries all over the world**
- **continually improve nuclear power station safety technology**

Continuous efforts to further improve safety
Scope covered by deliberations and investigations into unsolved issues

This report compiles the results of investigations and deliberations conducted from the viewpoints mentioned above. This is the third progress report following those given in December 2013 and August 2014

3. Investigation/Deliberation History

52 issues were identified as being unsolved events related to the detailed development of the incident following the accident

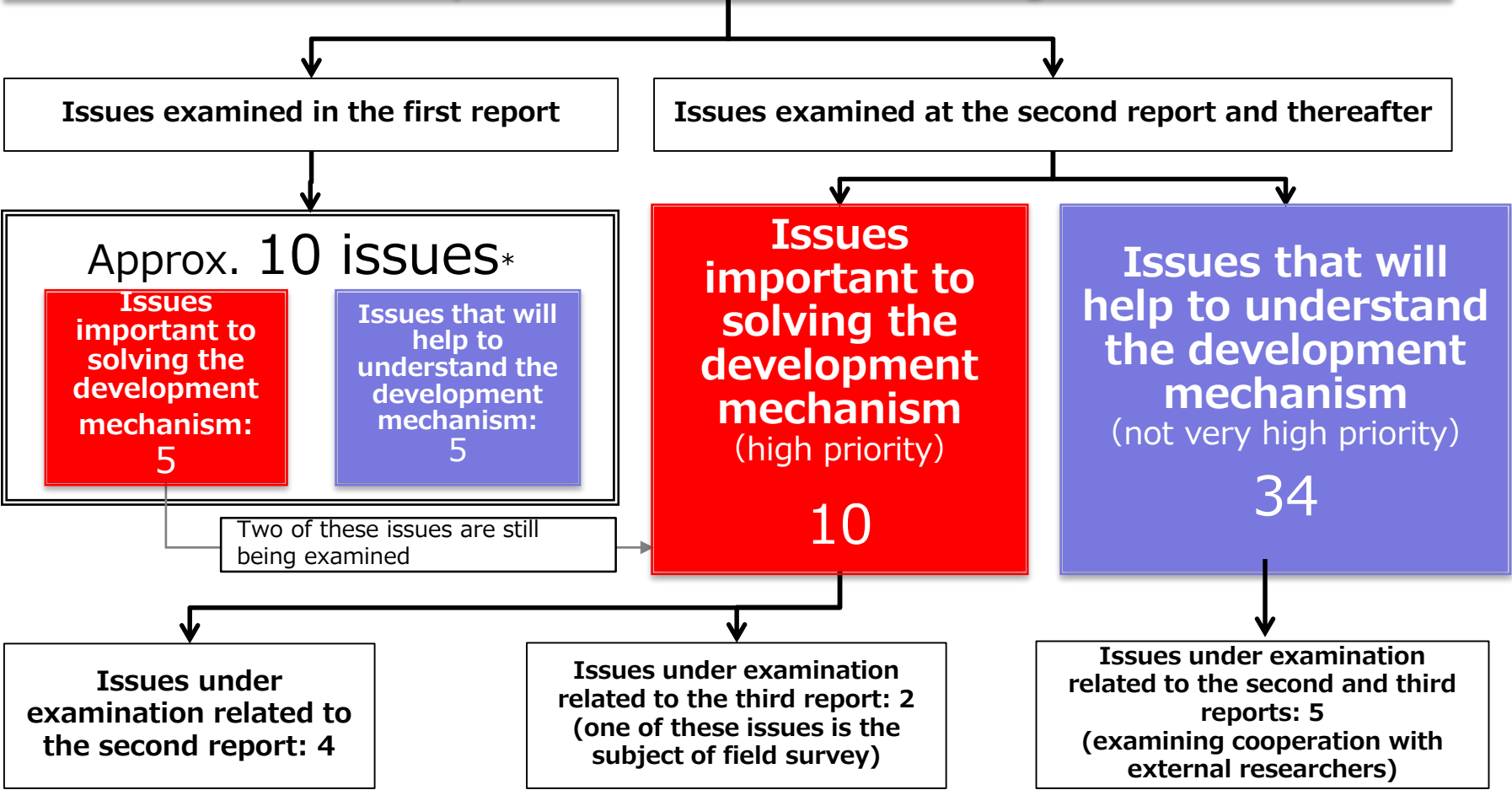

* Includes causes that have been revisited through additional investigations. The second report and reports thereafter examine the development mechanism.

2. Progress made in the study of ten high-priority issues

Issues reported on in the second progress report	Factors in the shutdown of the reactor core isolation cooling system at Unit 3	Unit 3-1
	Evaluation of HPCI system operational state at Unit 3 and its impact on the accident's progression	Unit 3-5
	Rise in reactor pressure following forced depressurization at Unit 2	Unit 2-7
	Improving the accuracy of our estimate of the volume of cooling water injections from fire engines into the nuclear reactor	Common-2
Issues covered in the current report	Success or failure of Unit 2 containment vessel venting (Rupture disk status of Unit 2)	Unit 2-9
	Cause investigation of dose increase around March 20th	Common-9
Issues under review (investigated by TEPCO)	Study of safety relief valve operation after reactor core damage	Common-1
Issues under review (government R&D projects, etc.)	Melted core material behavior when dropping to the lower plenum	Common-6
	Thermal stratification in the suppression pool at Unit 3	Unit 3-3
Issues for which review has yet to begin	Identification of causes for the high-dose contamination of pipes in the reactor cooling water system at Unit 1	Unit 1-9

5. Major Points of the Third Progress Report

1. Success or failure of Unit 2 containment vessel venting (priority issue)

Field investigations have revealed that radiation levels around the rupture discs were low, quite low even when compared to SGTS filters (downstream side) which are thought to have been affected by Unit 1 venting. This suggests that the rupture discs did not activate.

2. Investigation into the cause of site dose rate increases around March 20, 2011 (priority issue)

It was reconfirmed that conditions inside the plant did not change greatly during the time period when site dose levels increased. Given the changes in wind direction experienced on that day investigation results suggest that radioactive substances that were being discharged continually from the containment vessel were detected as a result of the change in wind direction.

3. Presumed accident development at Unit 1 based on new analysis results

Unit 1 accident development behavior was examined based on Unit 1 water level measurements and the results of accident development analyses. This has provided a certain degree of clarity in regards to the timing and location of leaks from the reactor pressure vessel.

4. Presumed accident development based on Unit 2 CAMS measurement data

Unit 2 CAMS measurement data was analyzed in order to examine accident development. This data suggests that it is highly possible that a large change in status occurred on the evening of March 15, and that there was a monotonic decrease in dose rates after March 15 thereby suggesting that reheating and melting will not occur again.

4 . Sharing insights and engaging in discussion with researchers from overseas

The Atomic Energy Society of Japan meetings/International meetings

We have given presentations on study results at academic and international meetings. We have been fortunate to receive awards for these presentations. We will continue our examination while considering comments that have been made and other achievements gained through these activities.

< Presentation >

AESJ meeting: Spring and Fall meeting 2013 - 2015

International meeting:

NURETH (Nuclear Reactor Thermal Hydraulics) 10th meeting

NUTHOS (Nuclear Thermal Hydraulics, Operation and Safety) 9th meeting, 2012 and 10th meeting, 2014

International Workshop on Severe Accident Research, Tokyo Univ.

Nuclear Regulation Authority, Japan The Committee on Accident Analysis

We explained our evaluation of the tsunami arrival time and the cause of the loss of all power sources, which is mentioned in the interim report made by the NRA. We will continue our examination using the results from field investigations and the analysis results from the Committee.

OECD/NEA BSAF Project

We have shared our study results and accident information with BSAF project members. Comparing simulation results obtained from domestic and foreign researchers and exchanging opinions are helpful in our examination of unsolved issues.

OECD/NEA : The Organization for Economic Co-operation and Development/The Nuclear Energy Agency

BSAF : "Benchmark Study of the Accident at the Fukushima Daiichi Nuclear Power Station" has been established to improve severe accident codes and analyze accident progression and current core status in detail for presentation of fuel debris removal, as a part of the R&D projects for the mid-to-long term response for decommissioning of the Fukushima Daiichi. The first phase has been in completion in 2014 fiscal year, and the second phase will begin in 2015 fiscal year.

Niigata Prefecture Technical Committee

We have explained the issues regarding questions and points of interest from the governor and committee members during the discussion at the Niigata Prefecture technical committee meeting on the verification of the Fukushima Daiichi accident and safety measures at Kashiwazaki-Kariwa NPS.

We are continuing our investigation while considering discussions and opinions with and from various parties and researchers

Report on the Results of Examination and Review on
Unconfirmed/Unclear Matters

Progress Report No.3

Matters studied

1. Unit 2 SGTS dose survey

(1) Overview

The relationship between the success or failure of Unit 2 containment vessel venting (whether or not the rupture disks worked) and the discharge of radioactive substances around 9 PM on March 14 is as yet unclear (Unit 2-9)

No inferences can be made under the current conditions.
A field survey is required to shed further light on the issue.

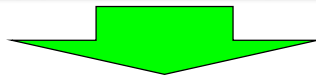

A dose survey of the rupture disks and the area around the SGTS filters shall be implemented in order to look for traces of venting flow



The SGTS filters (downstream side) were highly contaminated even though contamination was not found on the piping around the rupture disks

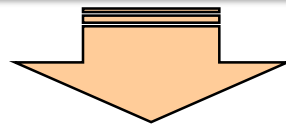

The condition of the rupture disks shall be checked in order to shed light on issue Unit 2-9 (whether or not the Unit 2 rupture disks worked) and the cause of contamination of the STGS filters, and the examination of radioactive substance release routes shall continue

(2) Unit 2 SGTS system schematic and survey location

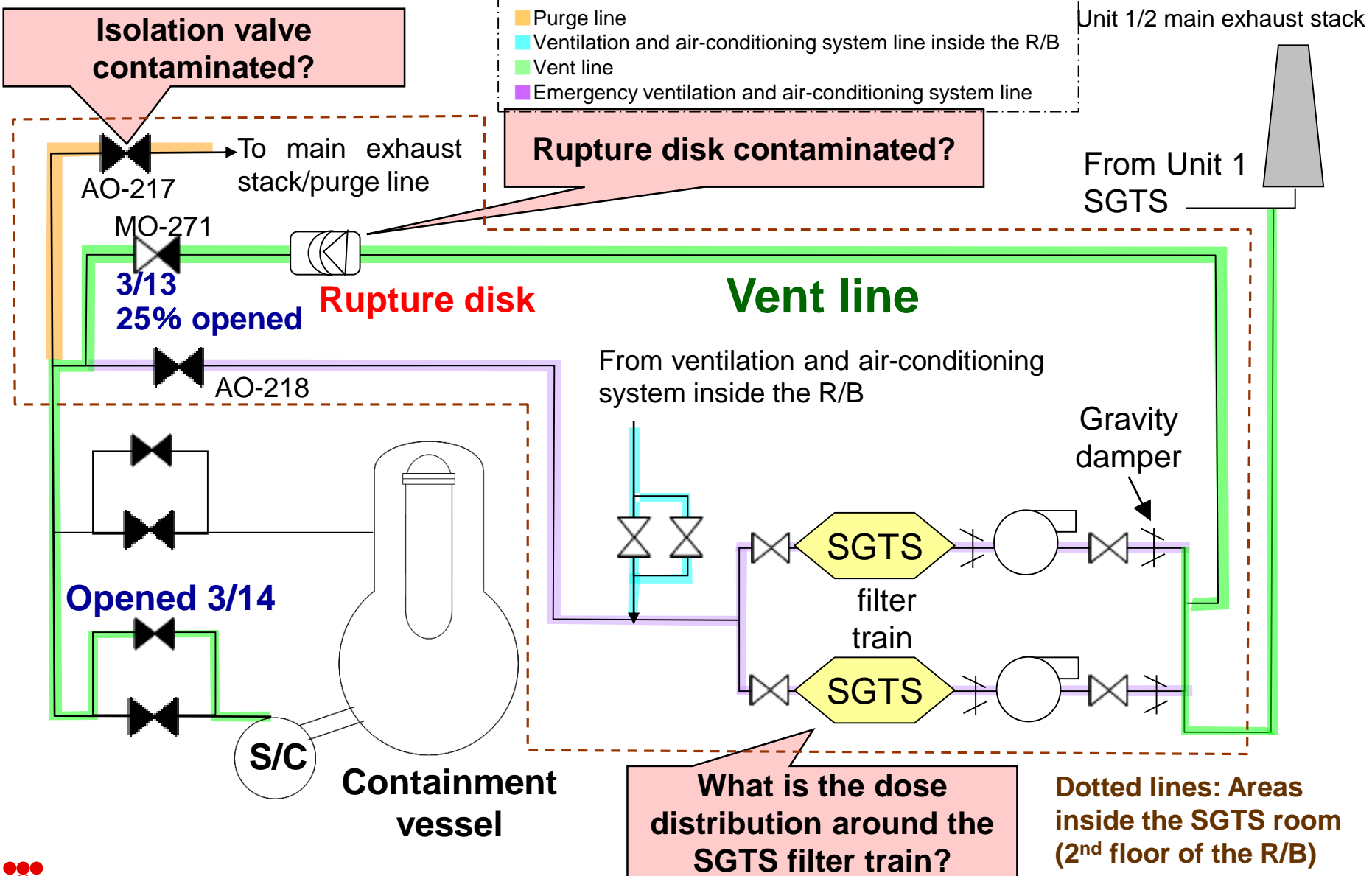

(3) Dose survey results ~ Around rupture disks ~

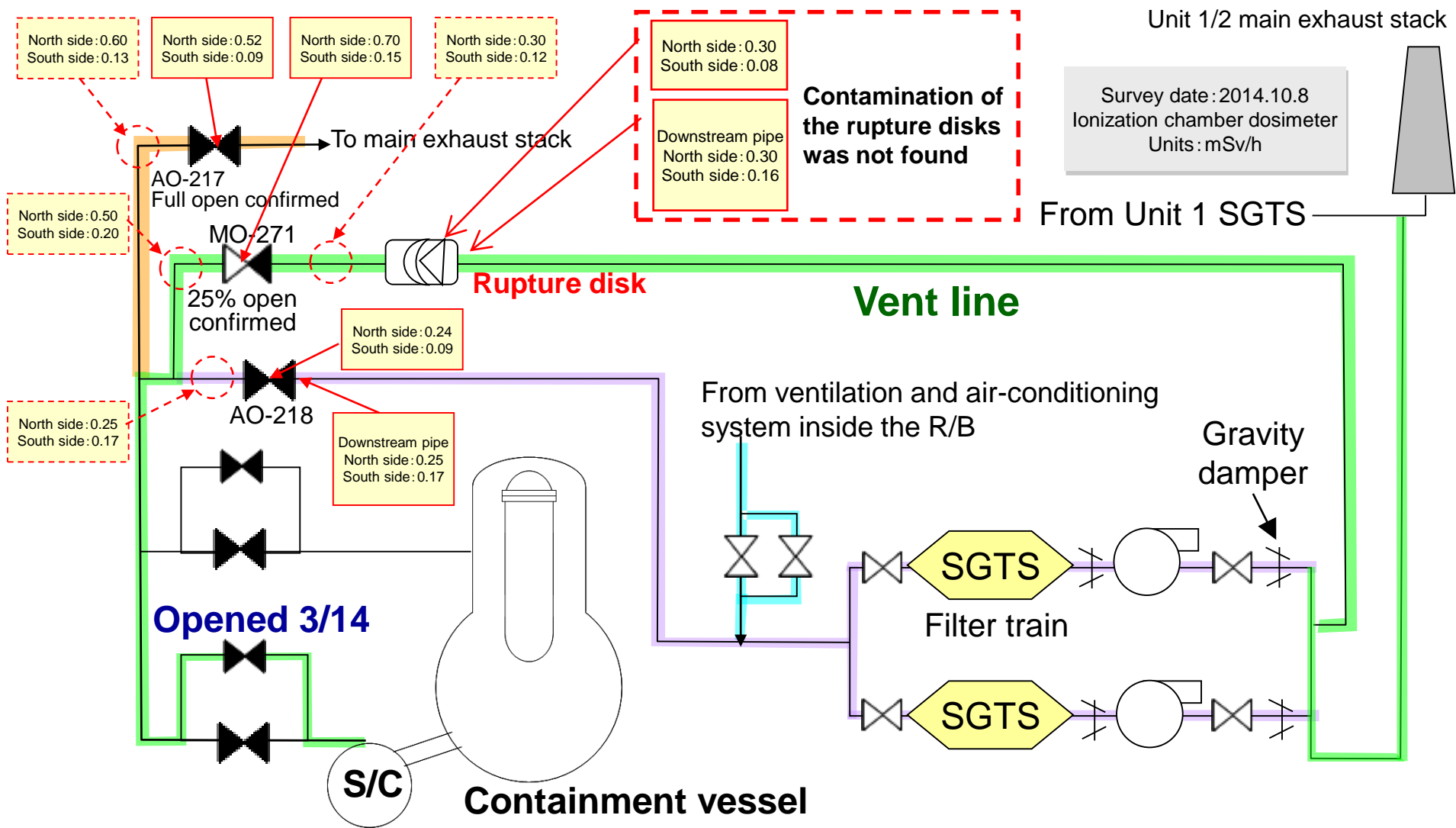

★The “north side” of the pipe surface dose refers to the dose measured from the SGTS filter side. “South side” values are lower due to shielding by the pipes. This means that doses from the SGTS dominate and that contamination of the pipes cannot be detected

(4) Dose survey results ~ SGTS filter train (A) ~

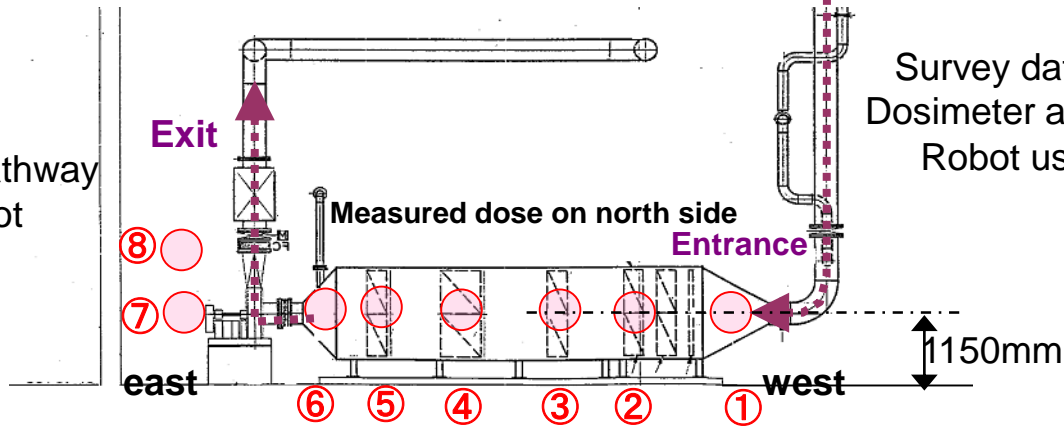
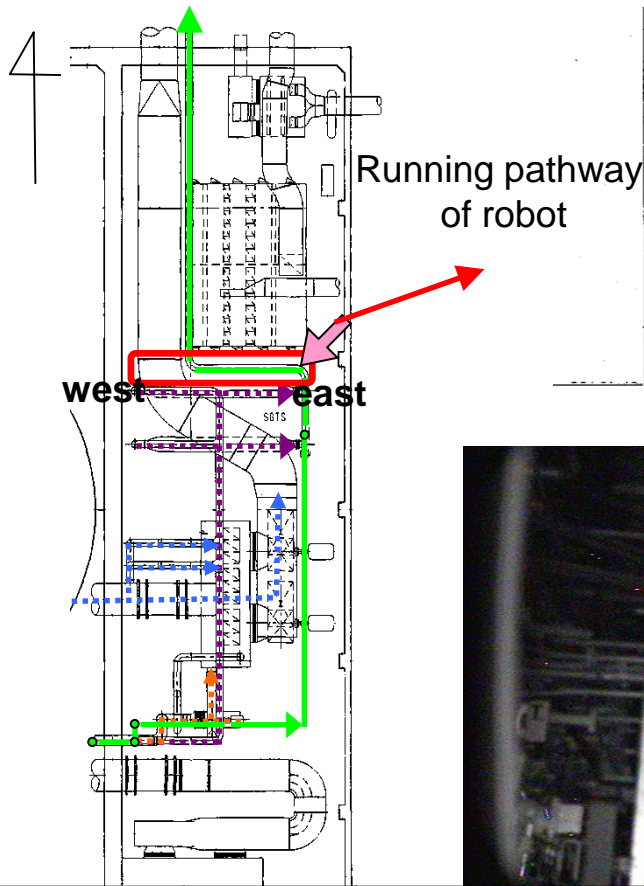

Survey date: 2014.11.12
 Dosimeter attached to robot
 Robot used: PackBot

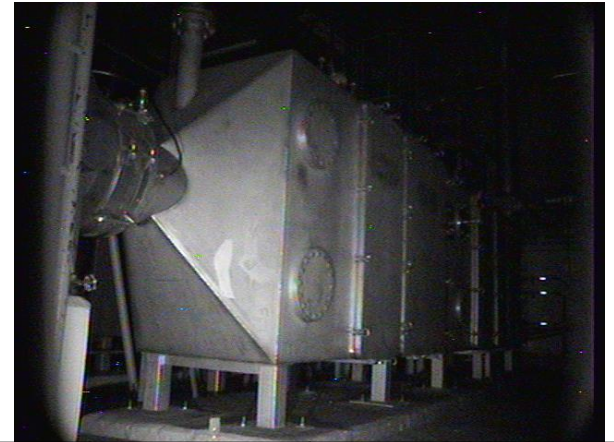
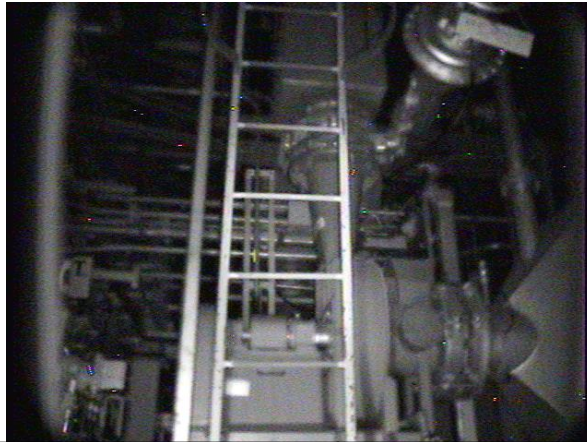

Measurement location	⑧-A	⑦-A	⑥-A	⑤-A	④-A	③-A	②-A	①-A
Measurement location	Outlet pipe	Outlet pipe	Outlet	HEPA filter	Charcoal filter	HEPA filter	Pre- filter	Inlet
Measurement height	2170mm	1150mm	1150mm	1150mm	1150mm	1150mm	1150mm	1150mm
Dose rate	79mSv/h	85mSv/h	400mSv/h	1Sv/h *	460mSv/h	220mSv/h	140mSv/h	69mSv/h

* Dose rate measured at a location approximately 20 cm away from the surface of the filter train (approximately 65 cm from the center of the filter)

(4) Dose survey results ~ SGTS filter train (B) ~

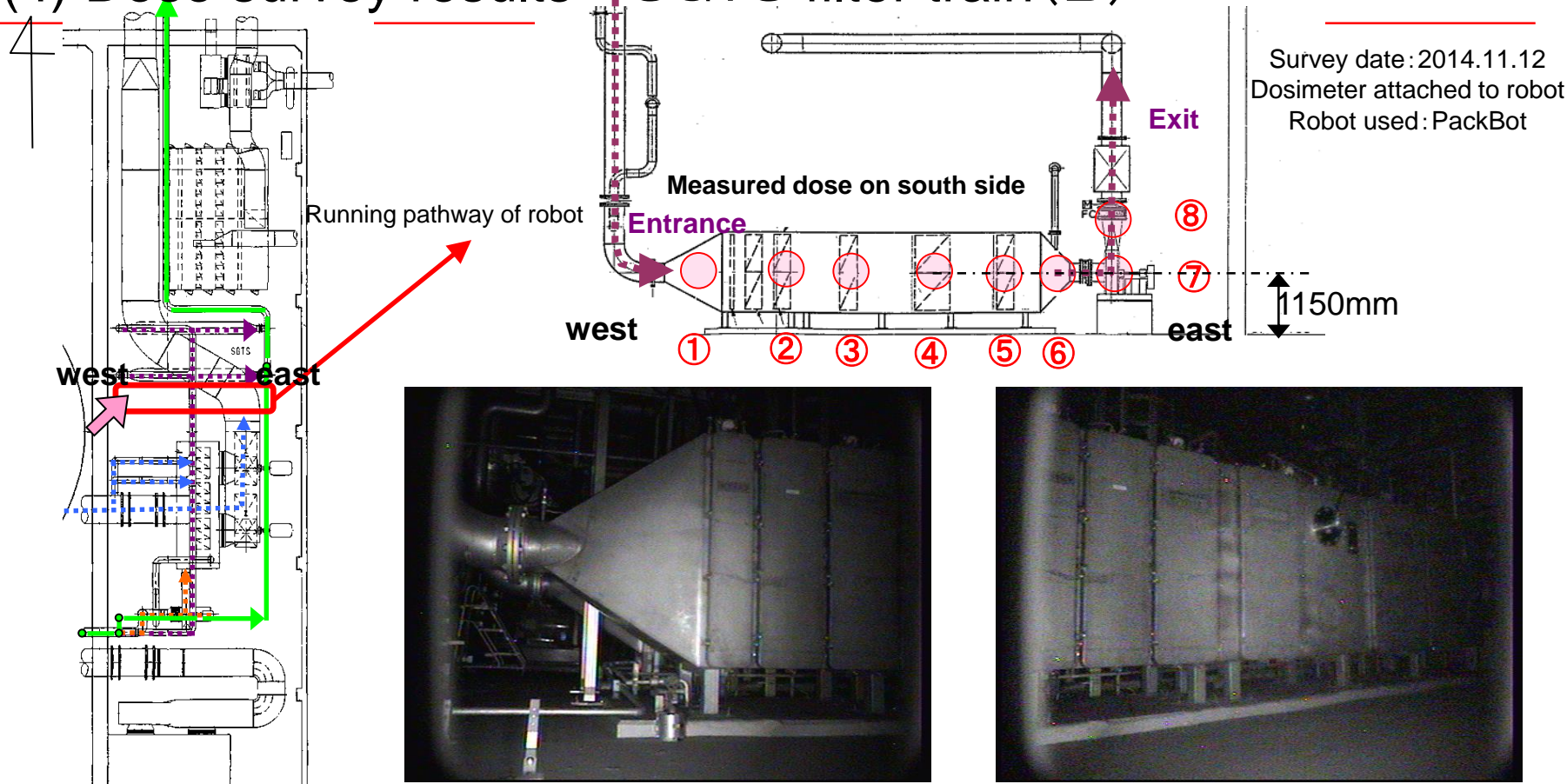

Measurement location	①-B	②-B	③-B	④-B	⑤-B	⑥-B	⑦-B	⑧-B
	Inlet	Pre-filter	HEPA filter	Charcoal filter	HEPA filter	Outlet	Outlet pipe	Outlet pipe
Measurement height	1150mm	1150mm	1150mm	1150mm	1150mm	1150mm	1150mm	2170mm
Dose rate	15mSv/h	29mSv/h	44mSv/h	160mSv/h	850mSv/h *	500mSv/h	210mSv/h	120mSv/h

*) Dose rate measured at a location approximately 20 cm away from the surface of the filter train (approximately 65 cm from the center of the filter)

(5) Dose survey results

High levels of contamination were found on the SGTS filter (downstream side)
⇒ It is possible that gases containing radioactive materials flowed back into the SGTS. This may have been caused by the following factors.

Possibility ① Back flow from Unit 2 venting

Possibility ② Back flow from Unit 1 venting

No contamination was found near the rupture discs.

⇒ It is highly likely that the rupture discs did not function

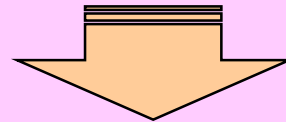

Further investigation into success and failure of Unit 2 containment vessel venting will be continued

2. The causes of the dose increase seen around March 20th

(1) Overview

On or around March 28 an increase in dose rate is on site at the Fukushima Daiichi NPS were measured. However, the cause of the aforementioned dose rate increase has yet to be identified

There are two possible causes of the dose increase.

- ① a new discharge of radioactive substances
- ② the detection of radioactive substances steadily being discharged from the containment vessel as a result of a change in wind direction

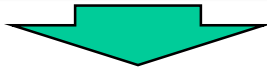

Examination based on plant data, accident handling records, and dose measurement results

There is no data or information to support possibility ①. In contrast, evidence supports possibility ②



Kashiwazaki-Kariwa NPS safety countermeasures

Dose rate increases inside the Fukushima Daiichi NPS site are caused by release of radioactive substances from the containment vessel, so maintaining the integrity of the containment vessel is vital

⇒ Various countermeasures for preventing loss of the containment vessel integrity shall be deliberated and implemented

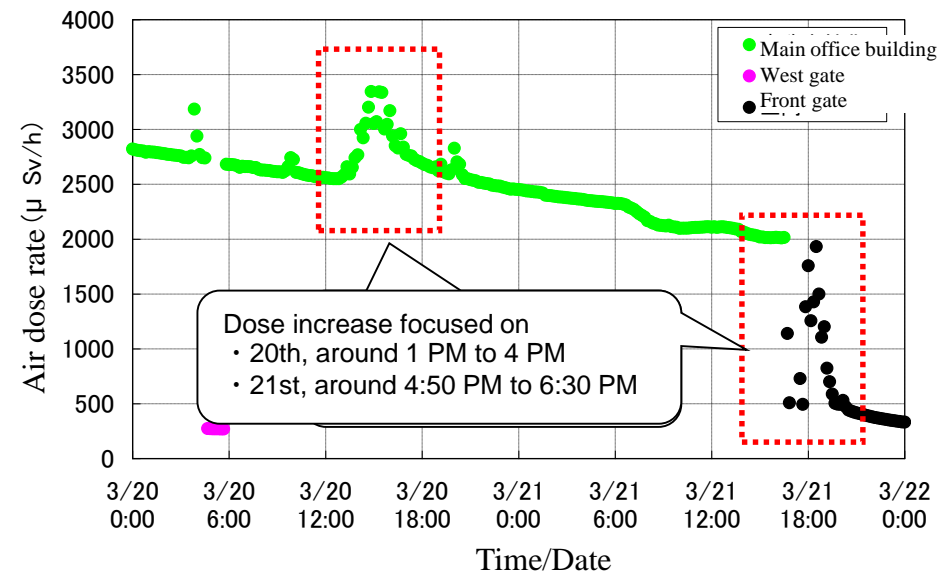

Fukushima Daiichi NPS site dose measurement results

(2) Examination based on plant data, accident handling records, and dose rate measurement results 1/4

Changes in plant data for units 1~3 during the period when dose rate increases were measured were examined in order to determine if there have been new discharges of radioactive substances

Plant	Reactor water level	Reactor pressure	D/W pressure	S/C pressure	CAMS (D/W)	CAMS (S/C)	Conclusions	Possibility of a new discharge
	○ indicates significant changes around the time of the dose increase							
Unit 1	×	×	×	×	○	×	CAMS (D/W) values decreased greatly at around 12 PM on the 20th. However, this was most likely caused by CAMS (D/W) indicator malfunction since no changes were seen in reactor pressure or containment vessel pressure, and because while the CAMS (D/W) values greatly decreased around 12 PM, the CAMS (S/C) values did not change greatly during the aforementioned time period.	Low
Unit 2	×	×	×	×	○	×	At 11 AM on the 20 th only one CAMS(D/W) measurement point was lower than the ones before and after it. This coupled with facts that there were no changes to CAMS(S/C) measurements during the same time period and no other changes were seen in other data, it is highly possible that the 11 AM measurement was due to an indicator malfunction.	Low
Unit 3	○	○	○	○	×	×	At around noon on March 20 reactor water level increased slightly while reactor pressure and containment vessel pressure decreased slightly. Meanwhile, around this time Unit 3 reactor pressure vessel and containment vessel temperatures both declined. It is assumed that the pressure declined in conjunction with a decrease in temperature. If there had been a discharge large enough to increase site doses it is highly likely that some change would have been seen in the CAMS indicators.	Low

When using plant data to examine the possibility of a radioactive substance release it is not sufficient to merely look for significant changes but rather necessary to examine the issue based on the interrelationship of the data. As a result, it was not possible to determine whether or not it is possible that a new release of radioactive substances occurred.

(2) Examination based on plant data, accident handling records, and dose rate measurement results 2/4

Accident response records (details of teleconferences between Fukushima Daiichi and the Head Office) were used to examine whether or not a new release of radioactive substances occurred.

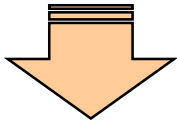

Black smoke was seen emanating from the southeast side of the Unit 3 R/B at around 4 PM on March 21

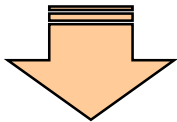

Unit 3 (March 21, 2011)

However, it was assumed that this was caused by the ignition by some means of oil in the PLR pump speed controller on the fourth floor of the reactor building. Since the unit was in operation at the time of the accident there were very few flammable materials inside the power station so it is quite possible that the aforementioned clause is accurate.



An examination of the accident handling records did not yield any evidence to support that there was a new release of radioactive substances

(2) Examination based on plant data, accident handling records, and dose rate measurement results 3/4

Dose rate measurement results were used to examine the possibility that the increases were the result of a change in wind direction

During the course of the accident the containment vessels for Fukushima Daiichi NPS Units 1~3 loss containment function and reactive substances were steadily being discharged outside the building. (Photo) The site dose rate increase measured around March 20 was most likely due to a change in wind direction that blew the steadily escaping radioactive substances the opposite way.



Aerial photo of Unit 3 (March 16, 2011)

(2) Examination based on plant data, accident handling records, and dose rate measurement results 4/4

Analysis of the percentage of measurement points that were downwind during the dose increase, and the percentage of measurement points that were in directions other than downwind thereafter when dose levels decreased.

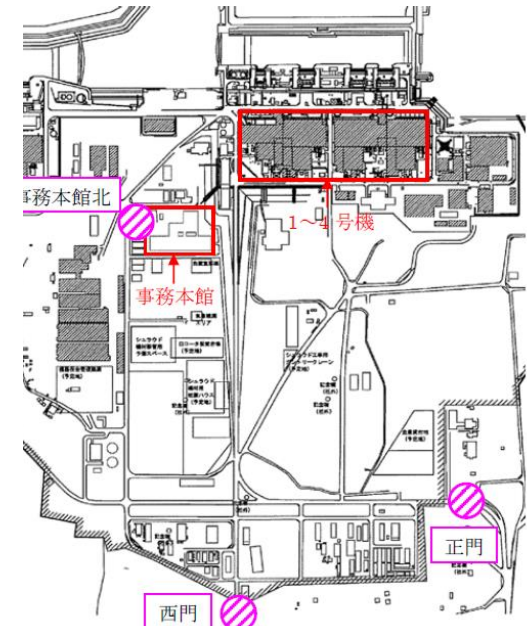
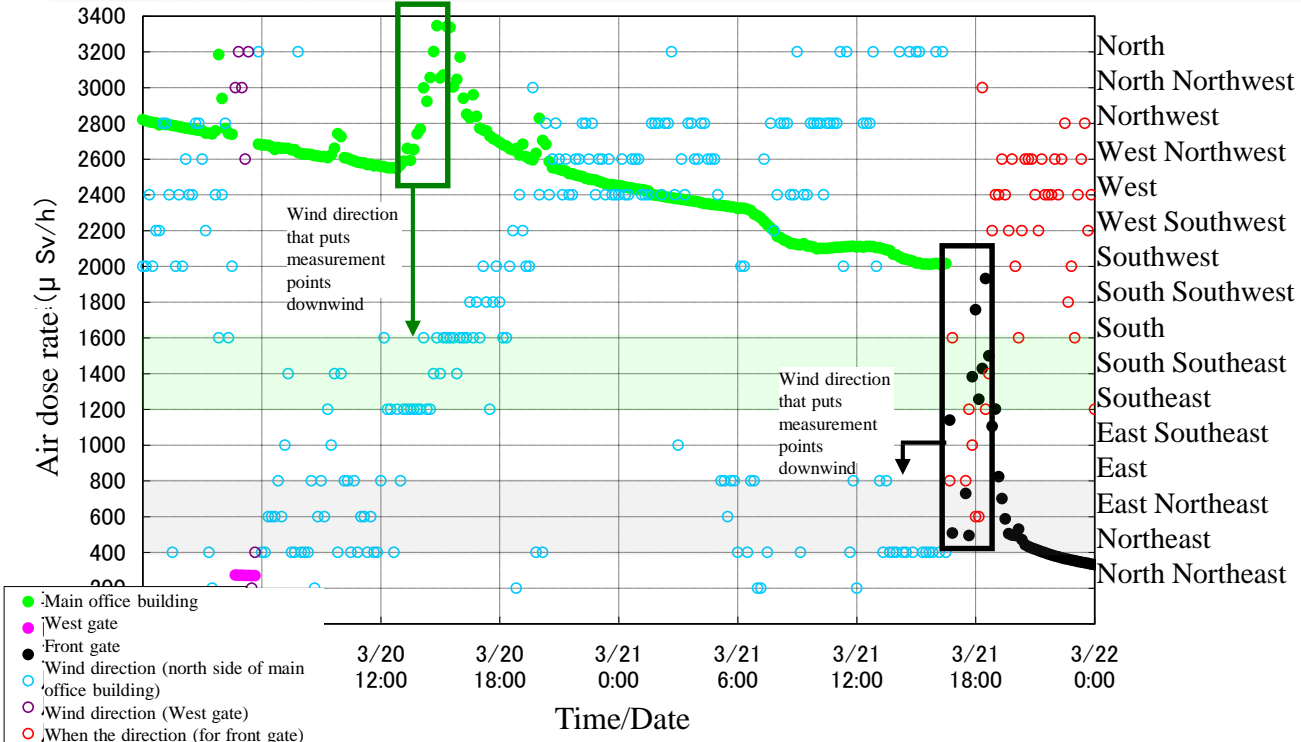

Dose measurement point diagram

Fukushima Daiichi NPS Site Dose Measurement Results and Wind Direction at Each Measurement Point

The results of the analysis show that a large percentage of the measurement points were downwind during the increase in dose levels, and in contrast when the dose levels decreased most of the measurement points were not downwind.

⇒ It is highly possible that because of the dose increase was due to a change in wind direction

(3) Kashiwazaki-Kariwa safety countermeasures

It is possible that containment function was lost during the Fukushima Daiichi NPS accident because silicon rubber that is used for hatch seals (gaskets) and the top-end flange of the containment vessel deteriorated because of the harsh environment to which it was exposed during the accident, such as high temperature steam. The following containment vessel rupture prevention countermeasures, which include countermeasures other than just preventing damage from high temperatures, are currently being deliberated and implemented, and safety measures will continue to be improved based on new knowledge that is obtained.

Containment vessel leak prevention: top head cooling, substitute spray systems for the containment vessel, coolant injection into the bottom of the containment vessel, filter event sealed material backups and material improvements

Suppressing the discharge of radioactive substances: Filter vents

Preventing hydrogen explosions: Filter vents, static catalyst recombination equipment

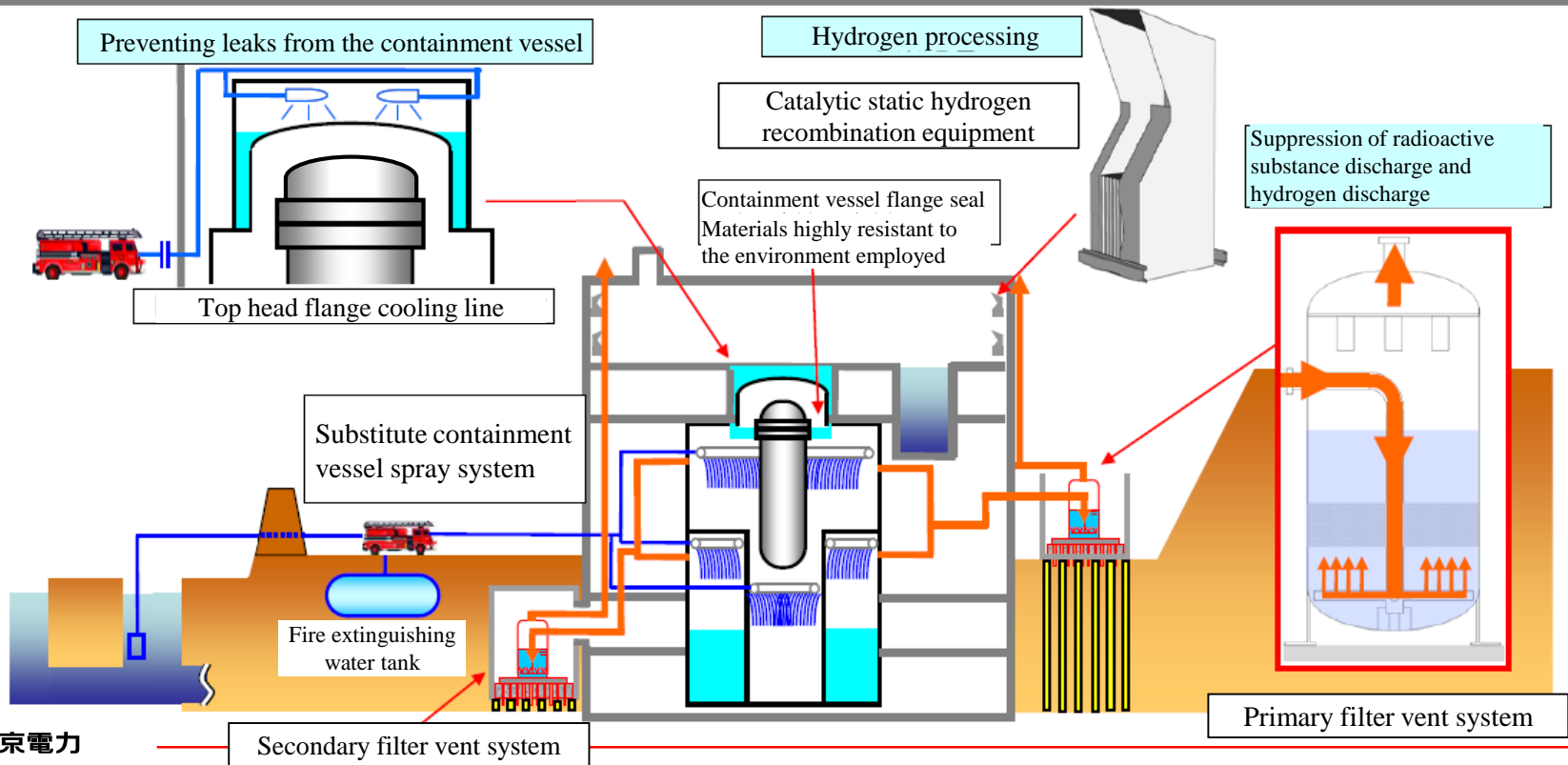

3. Unit 1 measurement data and accident development assumptions made based on past analysis results

(1) Overview

Plant data for Unit 1 is not sufficient as a result of the loss of power. It is also assumed that reactor water level measurement data is not accurate. (See Figure)

However, **it is possible to estimate how the accident developed** from changes in water levels, and assumptions can be made about accident development behavior by analyzing plant data, such as reactor water level meters, in conjunction with past analysis results.

- (1) Estimating accident development from Unit 1 plant data and past analysis results
- (2) Examining the inferences of (1) using a containment vessel internal thermal hydraulics analysis code (GOTHIC)

Primary knowledge obtained and an overview of how the accident developed

The results of the analysis performed in (2) suggest the possibility that the location of leak ② was not the main steam relief safety valve (SRV), but rather the top of the containment vessel

- ① 3/11 6:50 PM
Beginning of fuel damage, beginning of the generation of hydrogen, small-scale leak from reactor pressure vessel to containment vessel (D/W)
- ② 3/11 8 PM to 9 PM
Leak from reactor pressure vessel to containment vessel (D/W)
- ③ 3/11 11:24 PM to 12:30 AM
Melted debris flows into bottom of plenum (small scale)
- ④ 3/12 1:05 AM to 2:30 AM
Melted debris flows into bottom of plenum (large scale)
- ⑤ 3/12 around 6 AM
Damage to bottom head of reactor pressure vessel

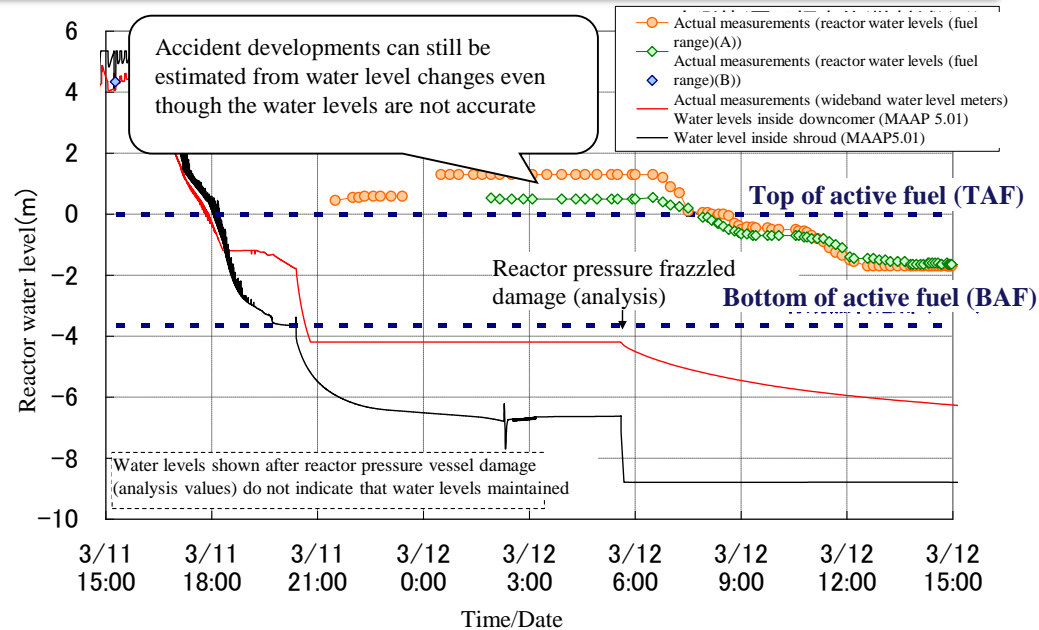

Unit 1 reactor water level changes

Reflected in Kashiwazaki-Kariwa safety countermeasures

- A leak at the top of the containment vessel means that containment vessel containment function was lost in conjunction with an increase in temperature ⇒ Containment vessel rupture prevention countermeasures implemented.
- DC power sources have been enhanced and spare storage batteries readied as reactor water level monitoring enhancement measures
- Thermometer installed in water level meter condensate tank (Enables the reliability of readings to be confirmed)

(2) Water level meter construction

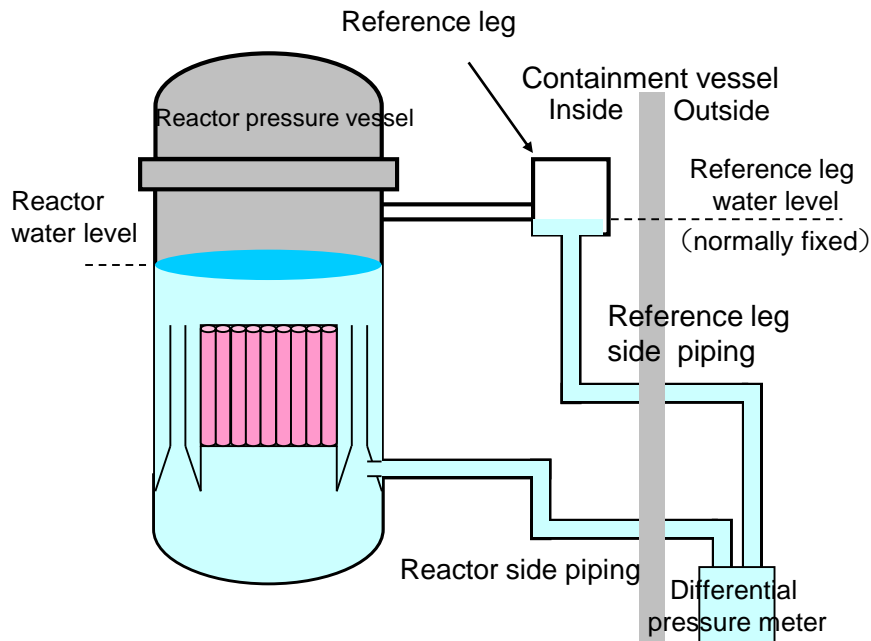

Water level meter diagram

- Reactor water level is calculated by the difference in head pressure between the reference leg side piping and the reactor side piping.
- Normally the reference leg side piping water level is kept at a fixed level. Changes in reactor water level are detected by changes in head pressure in the reactor side piping.
- Under harsh circumstances like those seen during the Fukushima Daiichi NPS accident when the temperatures inside the containment vessel become extremely hot, the water inside the reference leg side piping, which is normally at a fixed level, evaporates thereby causing the amount of water inside the pipe to decrease.
- As a result, it becomes impossible to accurately measure water levels inside the reactor. (If the water inside the reference leg side piping evaporates reactor water levels are estimated to be a little higher (they are overestimated))

(3) Results of analysis using the GOTHIC code 1/3

We performed thermal hydraulic analysis inside primary containment vessel by thermal hydraulics analysis code (GOTHIC) by utilizing analysis condition being set based on presumed accident progression.

A sensitivity analysis was performed on the gas leak from the reactor pressure vessel into the containment vessel that is assumed to have occurred during accident development ② (March 11 between 8 PM and 9 PM) after changing the assumed location of the leak
 【Case 1】 Leak location : Bottom of Containment vessel (near main steam safety relief valve (SRV))
 【Case 2】 Leak location : Top of Containment vessel

【Case 1】Leak location : Near bottom of Containment vessel (SRV)

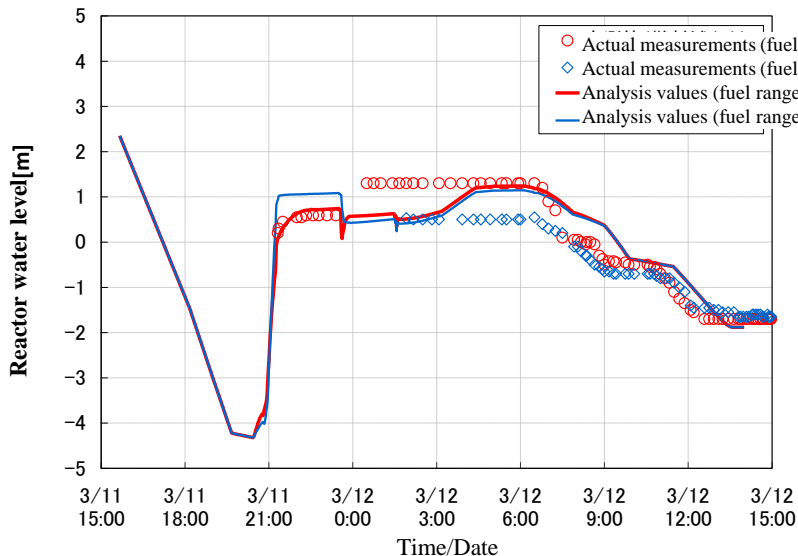

Reactor water levels

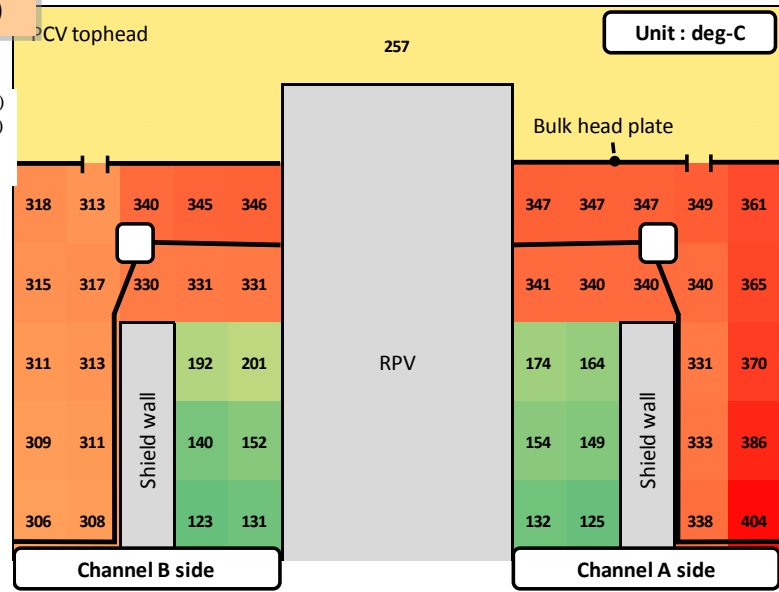

Containment vessel internal temperature distribution

The analysis showed that the temperatures inside the containment vessel increased evenly by and large, and the water level differences between System A and System B indicated by the actual measurement data were not seen.

(3) Results of analysis using the GOTHIC code 2/3

【Case 2】Leak location: Top of Containment vessel

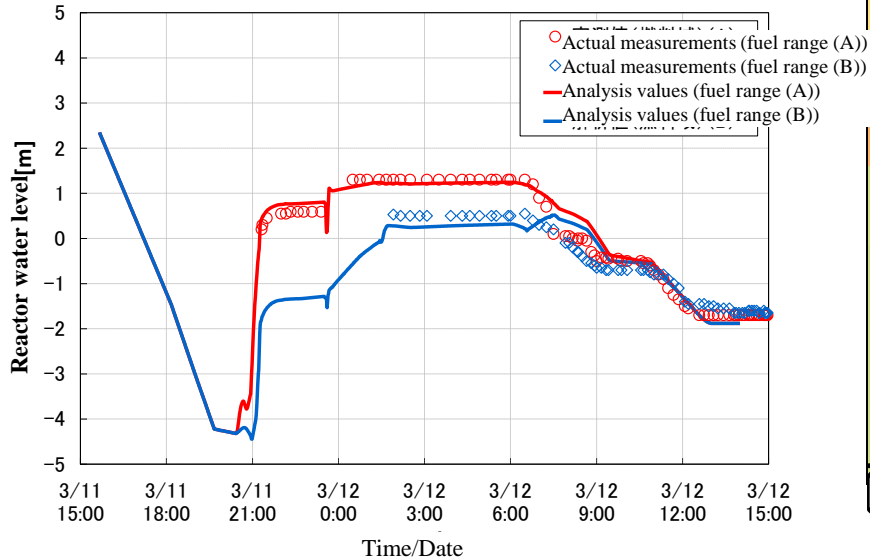

Reactor water levels

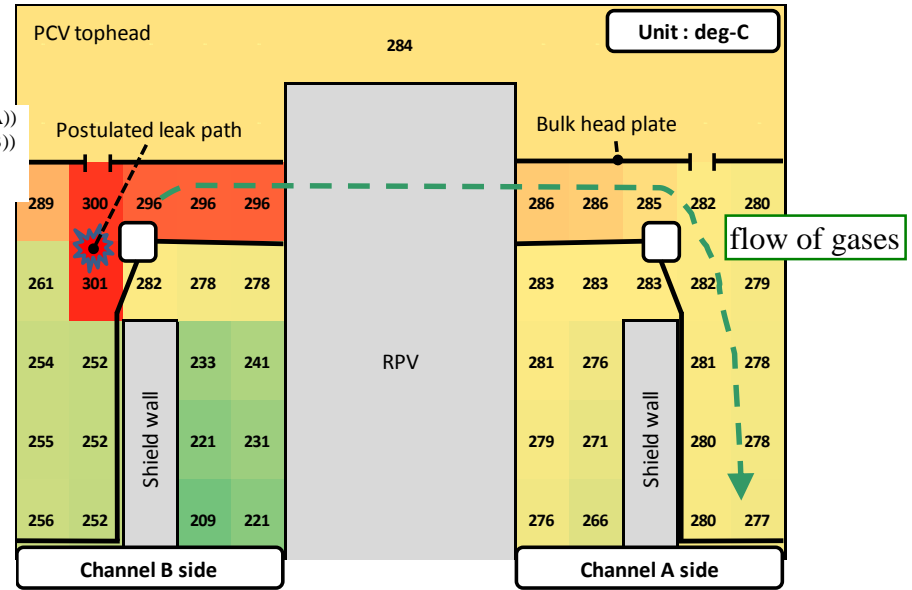

Containment vessel internal temperature distribution

The analysis showed that temperature increases are localized at the top of the containment vessel and that a decrease of water levels inside the water level meter reference leg side piping on one side can cause actual measurements to indicate a water level difference between System A and System B.



This suggests that the leak from the reactor pressure vessel to the containment vessel (D/W) occurred at the top of the contaminant vessel.
 This possibility will be further examined by revising analysis conditions as we continue to unravel the chain of events that happened during the accident.

(3) Results of analysis using the GOTHIC code 3/3

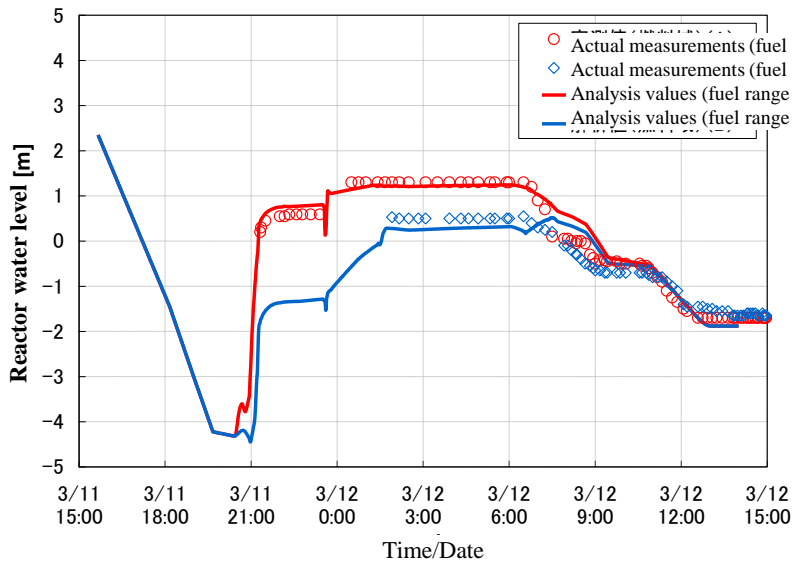

Reactor water levels
(Leak location: Top of Containment vessel)

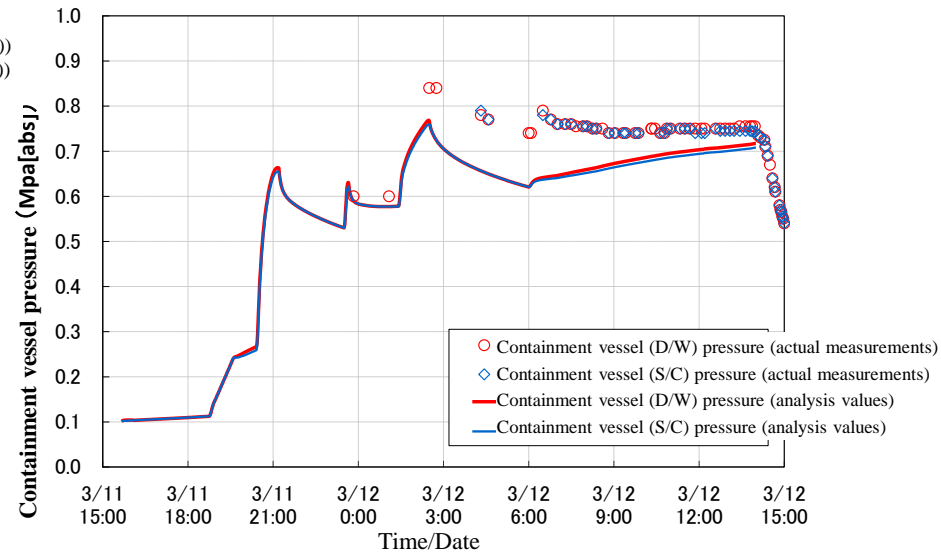

Containment vessel pressure
(Leak location: Top of Containment vessel)

In this analysis results, we could reproduce certain degree of reactor water level and primary containment vessel pressure



Supports the validity of the accident developments inferred from plant parameters and past analysis results

(4) Kashiwazaki-Kariwa Safety Countermeasures

Assuming that there was a leak from the top of the containment vessel, it is assumed that the top of the containment vessel would become extremely hot and it is therefore important to implement countermeasures to prevent damage by overheating. The following containment vessel rupture prevention countermeasures, which include countermeasures other than just preventing damage from high temperatures, are currently being deliberated and implemented, and safety measures will continue to be improved based on new knowledge that is obtained.

Containment vessel leak prevention: Top head cooling, substitute spray systems for the containment vessel, coolant injection into the bottom of the containment vessel, filter event sealed material backups and material improvements
 Suppressing the discharge of radioactive substances: Filter vents
 Preventing hydrogen explosions: Filter vents, static catalyst recombination equipment

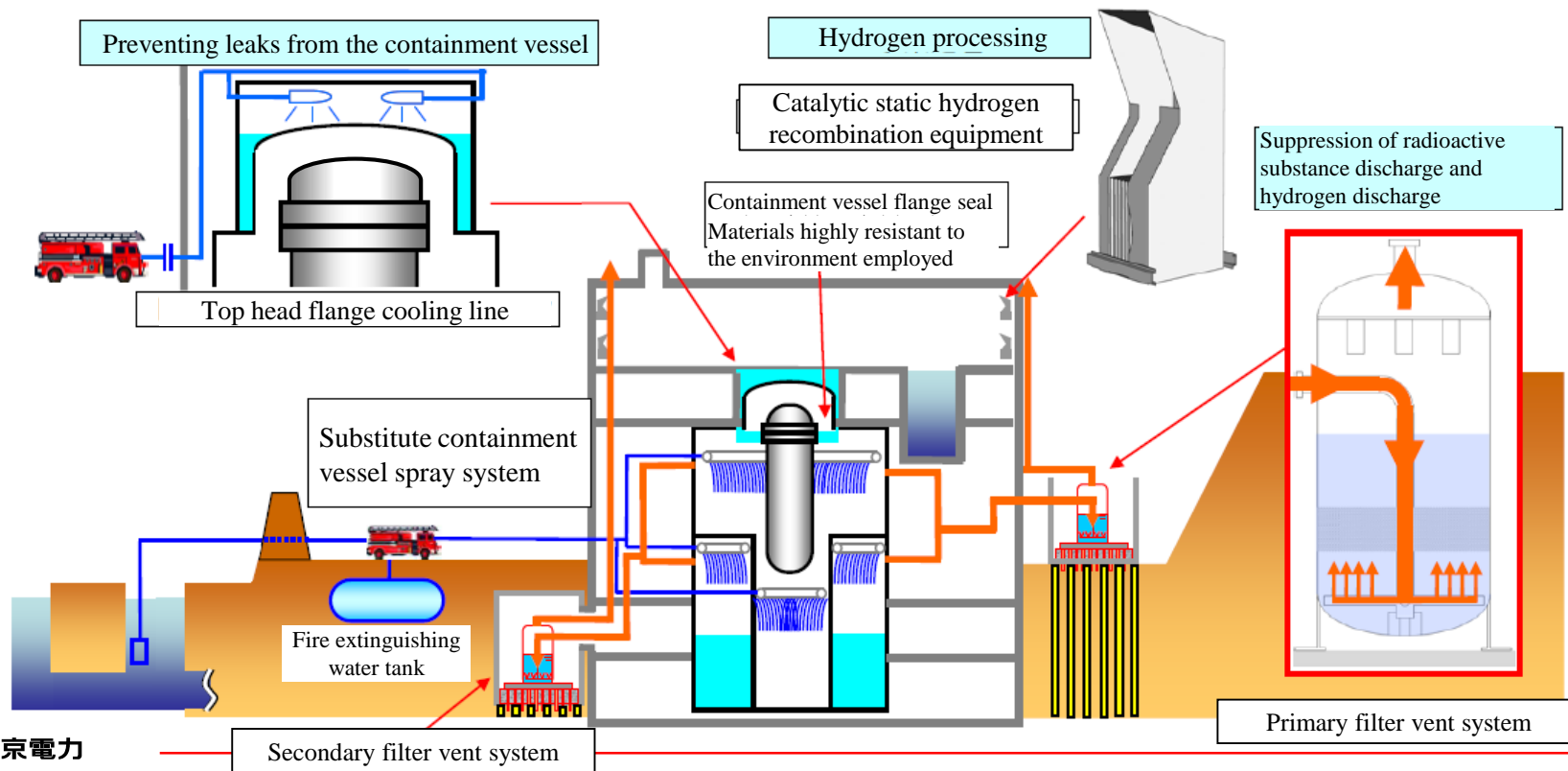

(4) Kashiwazaki-Kariwa Safety Countermeasures

Being able to accurately measure plant parameters during an accident is vital. In light of the inability to accurately measure water levels during the Fukushima Daiichi NPS accident due to a decrease in water levels in the reference leg piping, the following countermeasures will be implemented in order to increase the reliability of reactor water level measurements.

Enhancement of reactor water level measurements

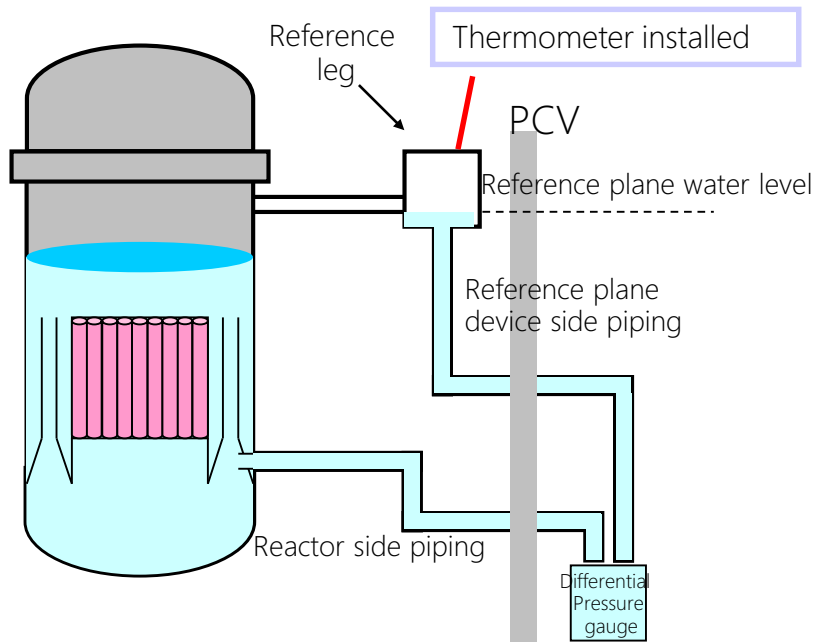

- A thermometer was installed in the reference leg in order to enable it to be determined if reactor water level meters are giving accurate readings during a severe accident.
- Even prior to the accident operation procedures stipulated that the reactor is to be filled completely with water if water levels are unclear, but methods for estimating reactor water levels if reactor water levels are unclear shall also be added.

Enhancement of DC power sources, readying of spare storage batteries

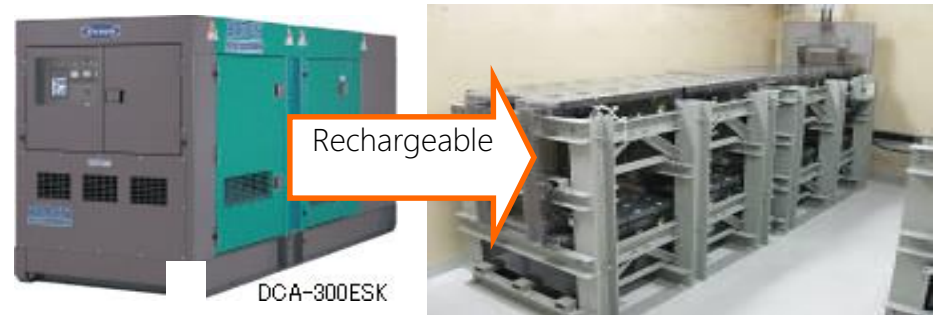

Extra rechargeable DC power sources have been installed on the top of the reactor building (this can also be used to power important monitoring instruments)



Spare storage batteries prepared in order to monitor reactor water levels (example)

4. Results of examination of Unit 2 CAMS measurement data

(1) Overview

Differing from Unit 1 and 3, the CAMS for measuring dose rate inside the containment vessel at Unit 2 was repaired prior to core damage and core meltdown and used to take data measurements. **The relationship between the accident developments that have become clear to date and the CAMS measurements have yet to be examined.**

Accident development at Unit 2 can be inferred by examining the characteristics of the CAMS dose rate measurements from the containment vessel D/W and S/C.



Accident developments at Unit 2 inferred from CAMS data

The data confirms that core damage and core meltdown occurred on the night of the 14th, and also supports the possibility of a large status change in the evening of the 15th.



Long-term CAMS data trends

Long-term CAMS dose rate measurement data shows a monotonical decrease from the maximum value of 138Sv/h recorded in the evening of March 15th. In other words, there was no reheating or remelting after March 15th.

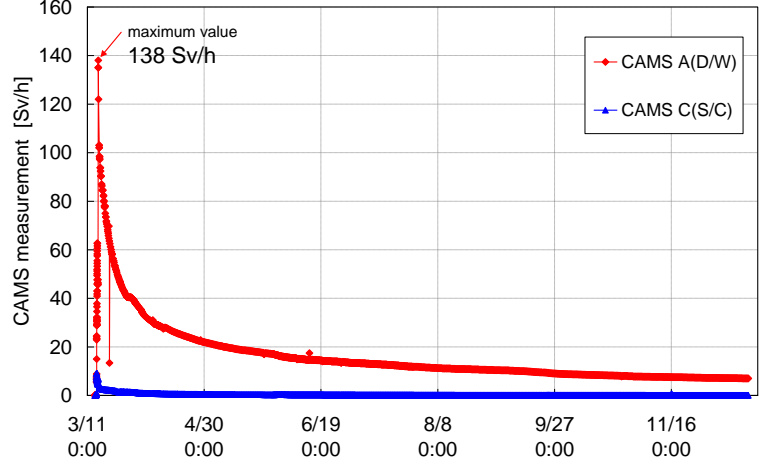
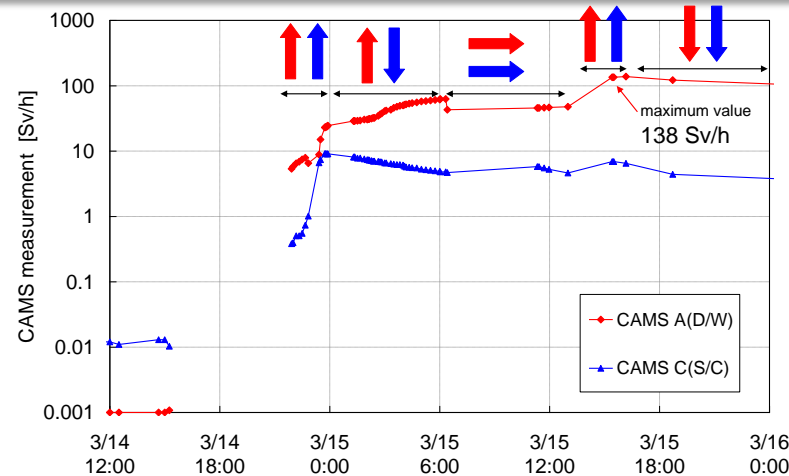

CAMS dose rate measurement data (Top: Short-term, Bottom: Long-term)

(2) Flow of gases during the accident (concept drawing)

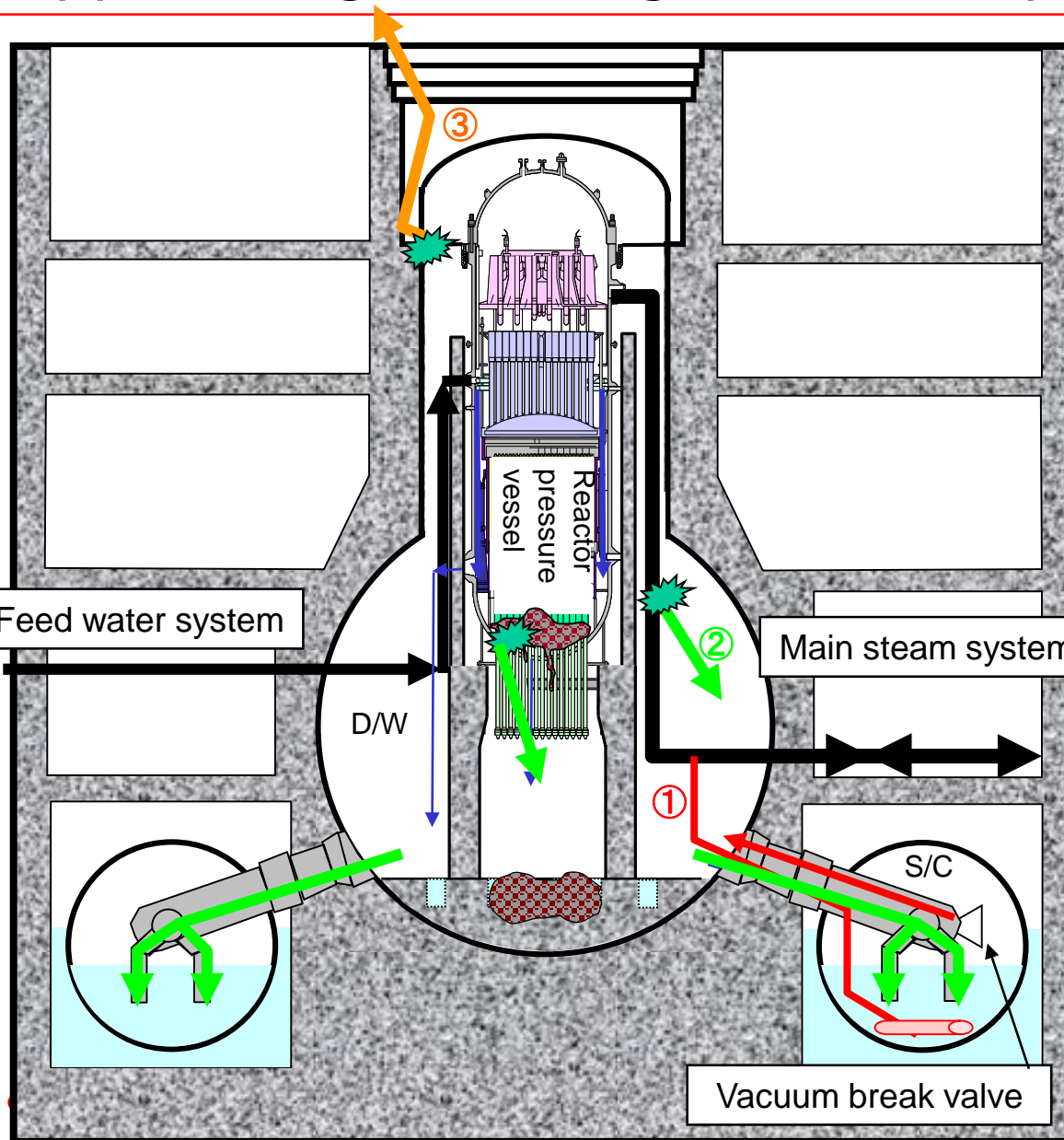

① Under normal reactor isolation condition steam generated inside the reactor pressure vessel during reactor isolation would pass through the main steam relief safety valve (SRV) into the S/C. If a pressure differential with the D/W exceeds a certain amount the vacuum brake valve would open causing gases inside the S/C to flow into the D/W.
<Flow of gases>
Reactor pressure vessel \Rightarrow S/C \Rightarrow D/W

② If there is a leak from the reactor pressure vessel into the D/W the gases inside the reactor pressure vessel would flow directly into the D/W. As D/W pressure increases the gases inside the D/W would flow into the S/C via the vent pipes.
<Flow of gases>
Reactor pressure vessel \Rightarrow D/W \Rightarrow S/C

③ If there is a leaked from the containment vessel to outside the reactor building, the gases inside the D/W would flow into the reactor building.
<Flow of gases>
D/W \Rightarrow Reactor building

(3) Accident development inferred from short-term CAMS measurement data

Period ①: Core damage begins, dose rates in D/W and S/C increase. Radioactive substances flow through the SRV from the reactor into the S/C and then into the D/W through the ruptured vacuum break valve.

Period ②: While D/W dose rates increase, S/C dose rates start to decrease. Indicates the possibility that radioactive substances are leaking directly from the reactor into the D/W

Period ③: No large dose rate changes are seen in either the D/W or the S/C. there is little measurement data for this period but it is possible that a state of equilibrium is reached

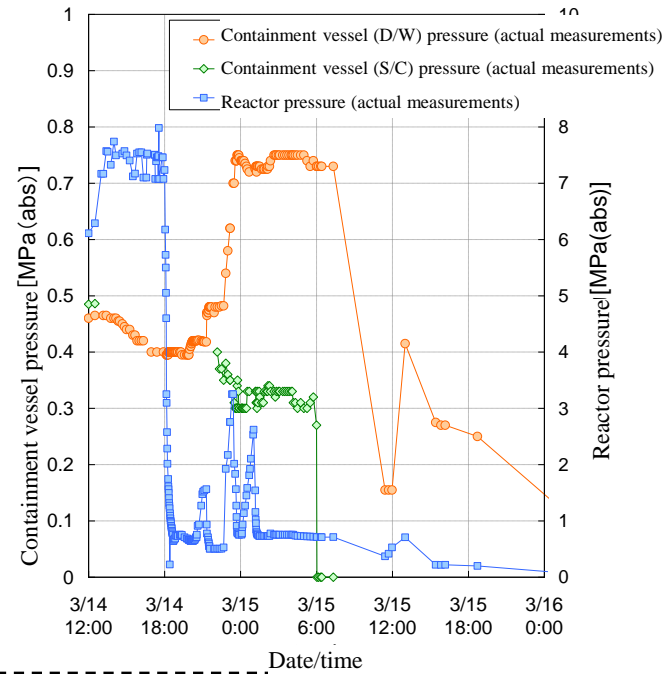
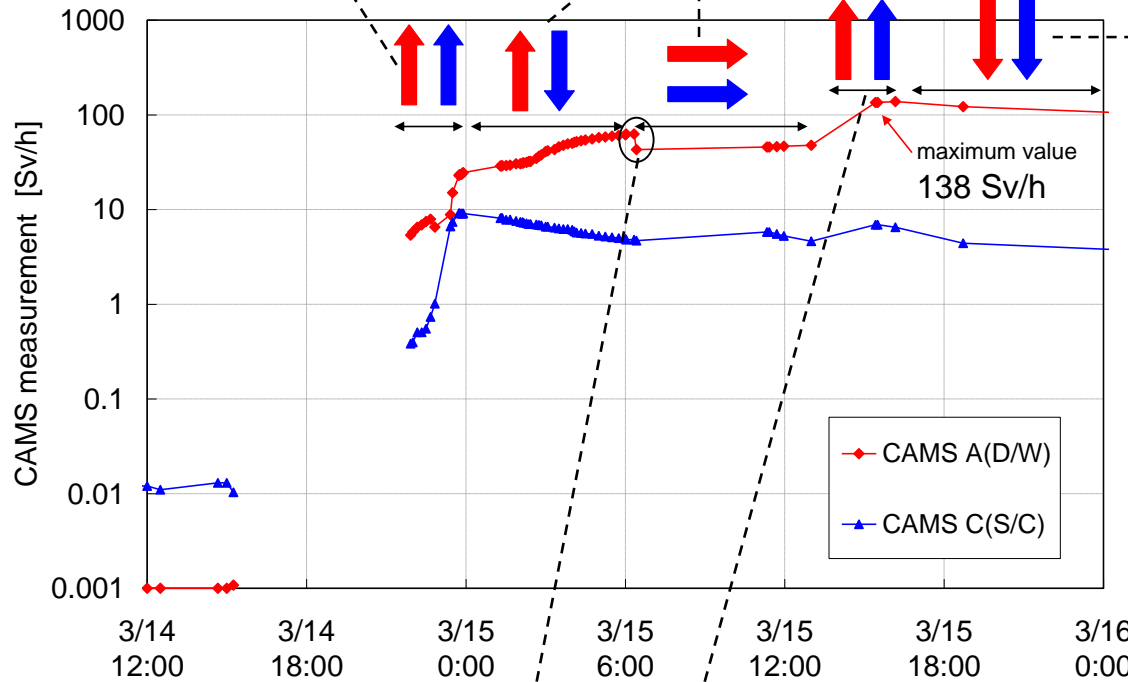

Early in the morning on March 15: Steam is seen emanating from the blowout panels, and records show that dose rates in the D/W decreased early in the morning on March 15 when dose rates increased. There is a possibility that this indicate a discharge of radioactive substances from the D/W.

Period ④: D/W dose rates quickly increase. Maximum value of 138Sv/h measured. S/C dose rates increase slightly thereby indicating a possible large status change at this point time. TEPCO estimates that the Unit 2 reactor pressure vessel was damaged and fuel had fallen into the containment vessel, but was the reactor damaged during this period of time?

Period ⑤: After maximum values are measured in both the D/W and S/C, dose rates steadily decrease

Glossary

- **BAF** Bottom of Active Fuel
Bottom pellet level in fuel assemblies
Heat is generated from decay heat in between BAF and TAF.
- **CAMS** Containment Atmospheric Monitoring System
Containment vessel atmosphere monitoring system. Device for measuring dose rates (Units: Sv/h) inside the containment vessel (D/W,S/C)
- **D / W** Dry Well
Space inside the reactor containment vessel, excluding the suppression chamber
- **GOTHIC** Generation of Thermal-Hydraulic Information for Containments
Computer software for analyzing thermal hydraulics inside the containment vessel. Can analyze target areas more specific than MAAP.
- **Lower Plenum**
Part located below the core in reactor pressure vessels
- **MAAP Analysis** Modular Accident Analysis Program
Analysis employing MAAP, a severe accident analysis code
- **MCCI** Molten Core Concrete Interaction
Reaction whereby a molten core fallen into the PCV reacts with concrete, resulting in decomposition and erosion
- **PCV** Primary Containment Vessel
- **Pedestal**
Space located below reactor pressure vessels inside the PCV
- **RPV** Reactor Pressure Vessel
- **Rupture disk**
Stoppage plate installed in vent lines that only rupture at certain pressures. They prevent external discharges of gases from inside the containment vessel in the event that the vent valve is mistakenly opened.
- **S / C** Suppression Chamber
- **SGTS** Stand by Gas Treatment System
Removes radioactive substances using filters in the event of a discharge of radioactive substances inside the containment vessel or inside the R/B
- **SRV** Safety Relief Valve
Valve that releases steam in order to prevent the reactor pressure vessel from being damaged by over-pressurization.
- **TAF** Top of Active Fuel
Top pellet level in fuel assemblies
- **Vacuum break valve**
This valve is installed to release pressure and make pressures equal if the pressure inside the suppression chamber exceeds that of the dry well.
- **Zirconium-water reaction**
Heating reaction whereby high-temperature zirconium (used for cladding, etc.) reacts with water vapor, generating hydrogen. At temperatures above 1200 degrees core temperature increases accelerate due to positive feedback.