

Reactor pressure behaviors at Unit-2

1. Introduction

The measured values and analysis results of reactor pressure changes at Unit-2 were inconsistent in the earlier report*¹, submitted to the Nuclear Industry and Safety Agency on May 23rd, 2011. The following describes the estimated causes of these discrepancies and the operation conditions of reactor core isolation cooling system (RCIC) assumed in the present MAAP analysis reported in March 2012. Figure 1 and Figure 2 present the reactor pressure changes obtained in the May 2011 analysis. The red frame in each figure shows where the measured values and analysis results were inconsistent.

2. MAAP results reported in May 2011

Unit-2 lost the power supply for control due to the effects of the tsunami, but the RCIC operation was continuing. Shutdown of the RCIC was decided to be at 13:25 on March 14th because the reactor water level decreased. This means the RCIC could inject water into the reactor for more than two days. During this time period, the reactor water levels measured by the fuel range water level indicators were from about 3,400mm to 3,950mm above the top of active fuel (TAF). The reactor pressures measured over the same time period were stable at about 5.4 to 6.4 MPa[abs], slightly lower than the pressure during normal operation, and they had decreased from about 7.1 MPa[abs] measured at 20:07 on March 11th.

In the May 2011 analysis, the RCIC was assumed to have been in operation at the rated flow rate (95m³/h) and there were repeated automatic start-ups and shutdowns between the reactor water levels L-2 and L-8. These assumptions were based on the considerations that RCIC operating conditions with no power supply for control had been unknown and the reactor water level had been maintained while the RCIC was in operation. As a consequence, the reactor pressure in the analysis was kept by repeating opening and closing of SRVs, which was inconsistent with the observed values. It should be noted that the RCIC operating conditions before the water injection was stopped would have little impact on the core conditions after the water injection was stopped, as long as the reactor water level had been maintained.

The RCIC operating conditions have been examined in the following chapters, as the reactor pressure changes would have depended largely on the RCIC operating conditions.

*1 "Analysis and evaluation of impacts of the operation records at the Fukushima Daiichi Nuclear Power Station when the Tohoku-Chihou-Taiheiyou-Okai Earthquake occurred", (May 23rd, 2011; in Japanese)

3. Possible RCIC operating conditions

From the following two considerations, the RCIC without the power supply for control would have not been operated in the "Operation Mode (rated flow rate)" as specified in the design. Furthermore, the RCIC would have not repeated start-ups and shutdowns in accordance with the reactor water levels (L-2 and L-8), either.

(1) Correction of reactor water levels

The reactor water level of Unit-2 was being monitored by the fuel range water level indicators after the accident on March 11th. The fuel range water level indicators are calibrated with reference to the atmospheric pressures and saturation temperatures. This is because the fuel range water level indicators were originally designed for monitoring the water level in a loss-of-coolant accident. They do not give the correct water levels when they are used in an environment of high reactor pressures and high drywell (D/W) temperatures. They need to be corrected.

When corrected*² for the reactor pressures and D/W temperatures, the reactor water level measured became a value close to the water level in the reference condensing water chamber (TAF +about 5,916mm) (Figure 3). Under normal conditions, the reactor water level never exceeds L-8 (TAF +5,653mm), since the RCIC is tripped once the reactor water level reaches L-8. At Unit-2, however, the RCIC with no power supply for control was likely to have continued its operation without being tripped. Decay heat decreased by that time, too. Therefore, the reactor water level was highly likely to have reached above L-8. If the reactor water level exceeds the reference water level, the apparent reactor water level stays there because the water level indicator cannot measure the pressure difference ($H_s - H_r$ in Figure 4) due to a limitation in its structural mechanism.

From the above, the reactor water level is considered to have exceeded L-8 and even the reference water level, while the RCIC was in operation.

(2) Driving steam for the RCIC

As discussed above, the reactor water level might have exceeded the reference water level of the water level indicators. In the case that the reactor water level further increased to

*² For correcting the reactor water level, the reactor pressure and D/W temperature are needed at the time when the reactor water level was measured. When the measured reactor pressure was not available at that timing, the pressure was roughly estimated by linear interpolation of measured values at other timings. The D/W temperatures were cited from Reference 1, as no measured values are available. Therefore, the corrected reactor water level in Figure 3 includes the errors of estimating the reactor pressures and D/W temperatures in addition to the measurement errors. It should be noted that the reactor water level correction curve for reactor pressures and D/W temperatures is presented in the emergency operation procedures.

become as high as the level of the main steam line (TAF about +7,301mm) or even higher, carry-over of water droplets into the main steam line may not be ignored. The driving steam for the RCIC turbine might have been two-phase flow. The RCIC water injection performance with low quality driving steam in two-phase flow is difficult to evaluate quantitatively, but at least the RCIC turbine rotation speed would have decreased and the RCIC would have injected water at a lower flow rate than normal.

4. MAAP results reported in March 2012

The reactor pressure changes obtained by MAAP analysis based on the assumptions discussed in Chapter 3 above are shown in Figure 5. The figure shows that the actual reactor pressure changes could be well reproduced when the RCIC flow rate was set at $30\text{m}^3/\text{h}$, about one-third of its rated value $95\text{m}^3/\text{h}$.

It should be noted that the reactor pressure remained stable at a lower level (about 5.4 to 6.4 MPa[abs]) than normal while the RCIC was operating. The reason could be that the RCIC had been driven by the two-phase flow which had higher energy at the saturated conditions than single-phase flow of steam. If this is true, the energy transfer from the reactor pressure vessel to the suppression chamber (S/C) becomes larger than in normal operation, and the heat removed from the reactor vessel could have balanced with the decay heat energy.

5. RCIC operation from the viewpoint of the design

In general, the quality of steam for the RCIC turbine, even when slightly downgraded from the design conditions, does not immediately damage turbine blades or damage the turbine itself. The drain water is discharged to the S/C and does not remain in the turbine. Therefore, the RCIC could have continued its operation being driven by the two-phase flow.

If the water level further increased and the main steam line (RCIC steam supply line) was covered or almost covered, the steam to the RCIC turbine becomes insufficient, and the rotation speed of the turbine may decrease and eventually the turbine may stop. It is also possible that, before the turbine stops, the steam supply to the RCIC turbine may be recovered for the following reasons: the amount of water injection decreases due to the reduced turbine rotations, the reactor water level decreases and steam reaches the RCIC turbine via the main steam line. In this case, the reactor water level may remain at a level near the level of the main steam line.

It should be noted that, when the RCIC loses its power supply for control, its regulator valve is fully opened by a spring force and the flow control is no possible anymore (a schematic diagram of the RCIC is given in Figure 6).

6. Evaluation concerning RCIC performance degradation

It was decided that the RCIC had stopped at 13:25 on March 14th because of the reactor water level decrease. But, as discussed above, the water level indicators are likely to have indicated a constant value, when corrected for the reactor pressures and D/W temperatures, close to the reference water level. Therefore, the measured water level decrease after about 12:00 is likely to show that the water level, having been higher than the reference level, decreased to this level. This hints that functioning of the RCIC had deteriorated earlier, before the water level decrease was observed at about 12:00. On the other hand, the reactor pressure started to increase from about 09:00 on March 14th. This can be considered due to the reduced amount of injected water caused by the RCIC function deterioration and due to the reduced steam supply to the RCIC turbine.

This pressure increase until about 12:00 on March 14th was slower in its increase rate than that of the normal RCIC shutdown (steam supply termination by closing the turbine throttle valve). This can be considered due to the failure to close the valve on the steam supply side because of no power supply for control. On the other hand, the pressure increase became faster after about 12:00 on March 12th. This fast pressure increase could be reproduced in the analysis by assuming no more steam supply to the RCIC turbine by the valve closure on the steam supply side.

7. Conclusion

The following points have been concluded, although some uncertainties remain.

- Reactor water level increased to above L-8 and the low quality two-phase flow removed energy equivalent to decay heat from the reactor by continued operation of RCIC due to loss of power supply for control.
- The RCIC injected water at a lower flow rate than the rated value, because it was driven by the low quality two-phase flow.
- The energy in the reactor pressure vessel was balanced without SRV operations and the reactor pressure remained stable at a lower value than in normal operations.

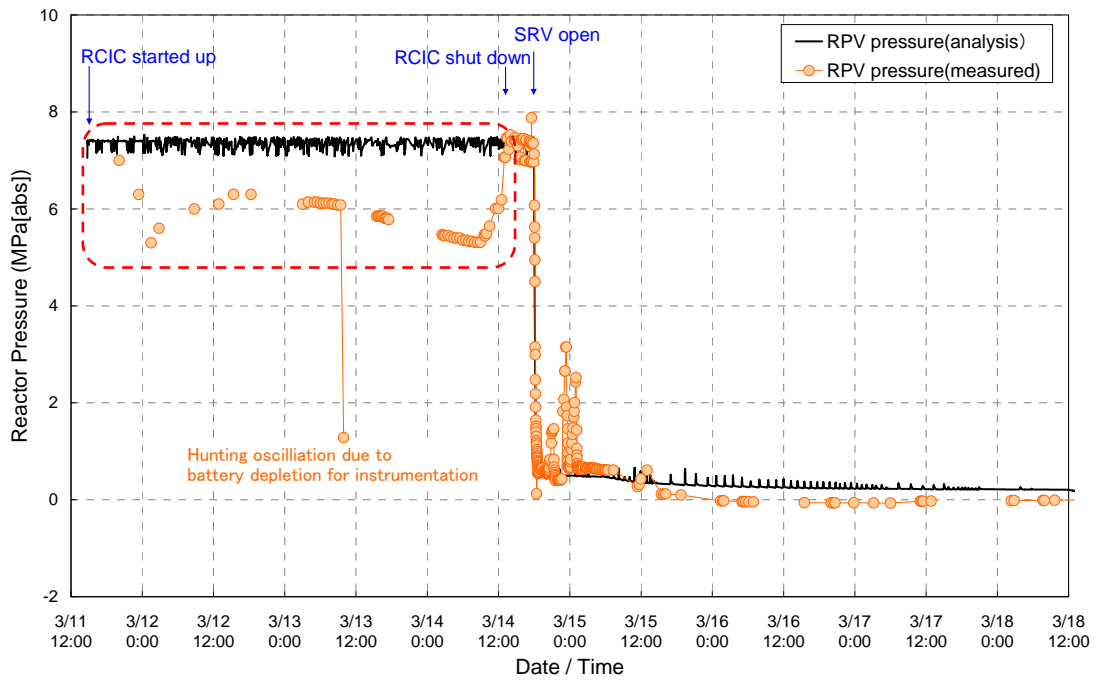

Figure 1 Reactor pressure changes at Unit-2
(MAAP results case-1 Figure 3.2.1.2 in the May 2011 report)

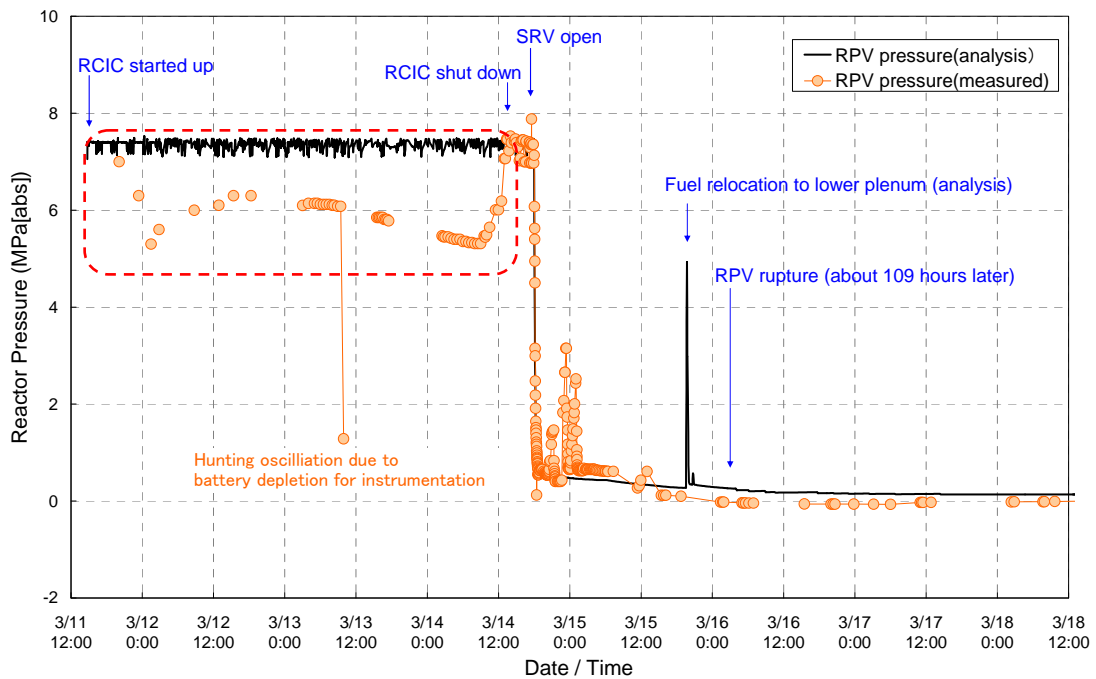

Figure 2 Reactor pressure changes at Unit-2
(MAAP results case-2 Figure 3.2.2.2 in the May 2011 report)

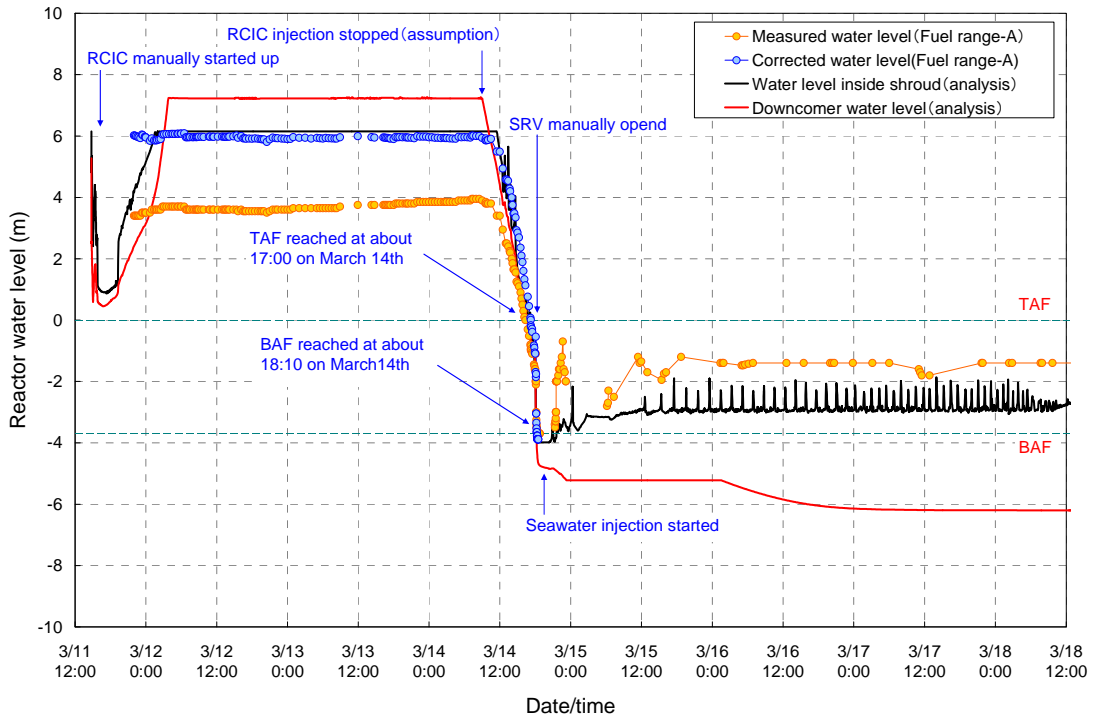

Figure 3 Reactor water level changes at Unit-2 (MAAP results reported in March 2012)

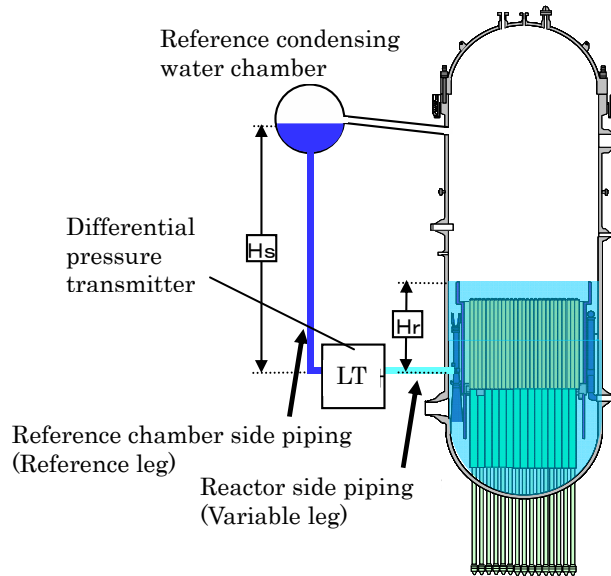

Figure 4 Structure of a reactor water level indicator

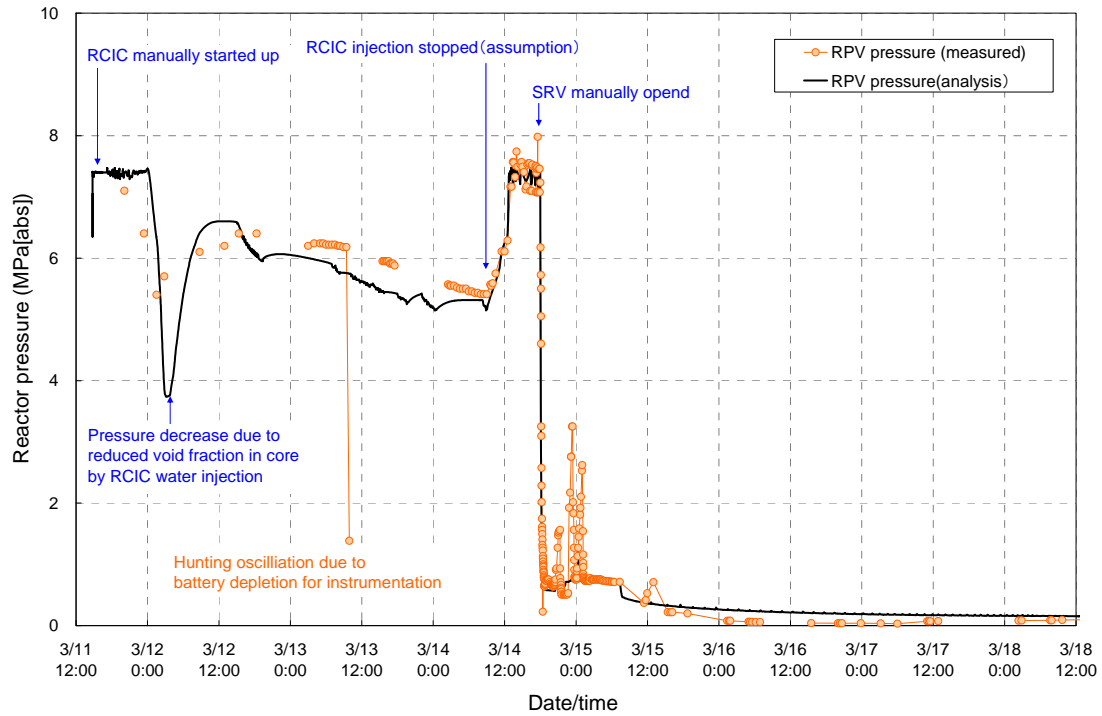

Figure 5 Reactor pressure changes at Unit-2 (MAAP results reported in March 2012)

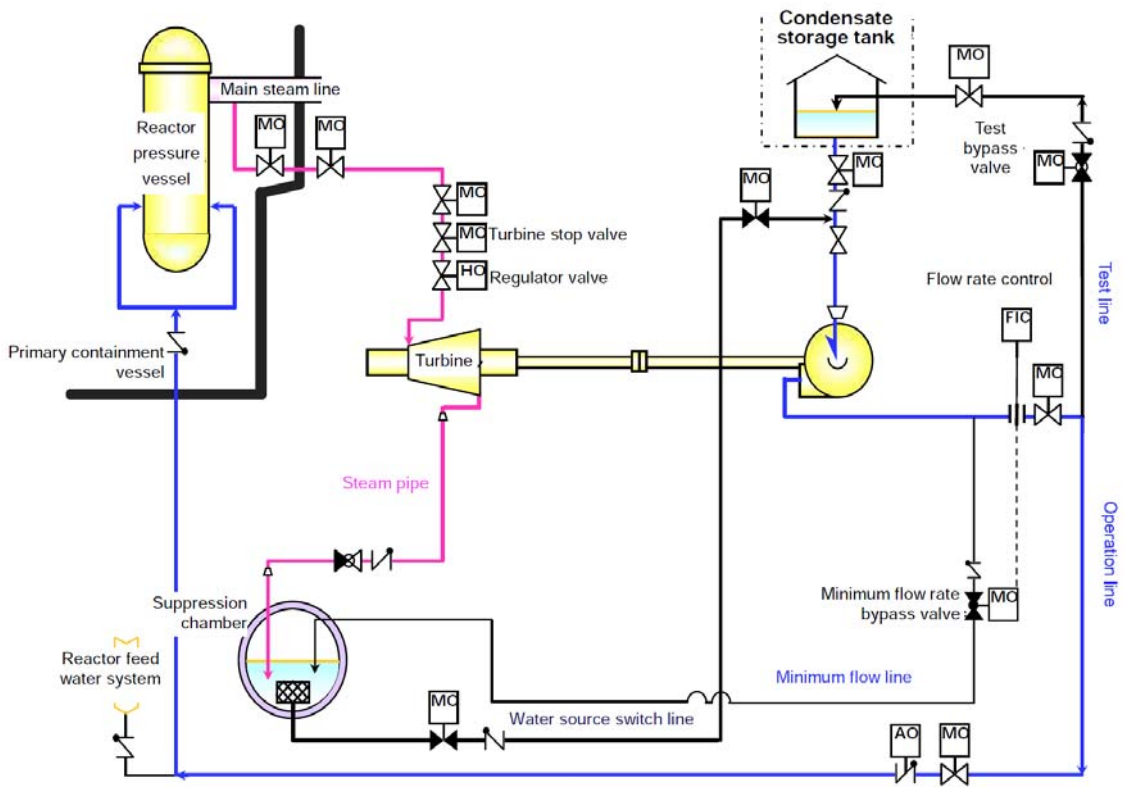

Figure 6 Schematic diagram of RCIC