

On July 22, 2011, TEPCO conducted the first-stage of a two-stage comprehensive assessment (Stress Test) on Units 1 and 7 at the Kashiwazaki-Kariwa Nuclear Power Station according to the instruction of "the implementation of a comprehensive safety assessment of existing nuclear power generation facilities based on the lessons learned from the accident at the Fukushima Daiichi Nuclear Power Station" by the Nuclear and Industrial Safety Agency. The outcome of the assessment is shown in this report.

Contents of Stress Test Report

- Assessment of the safety margin of the nuclear power station for the events exceeding design bases.
 - Multi-faceted efforts including thorough countermeasures against tsunami, fuel damage prevention measures and accident mitigation measures following the accident at the Fukushima Daiichi NPS.
- <Remark>
- Primary assessment (this assessment):
The reactors currently undergoing regular inspections and ready to resume operations are subject to the assessment of their safety margins for safety critical facilities and equipment for the events exceeding design bases (functional loss is assumed for those which exceed the evaluation standard values in light of conservative assessment and they are excluded from damage level assessments).
 - Secondary assessment:
All reactors are involved in comprehensive safety assessments (detailed assessments of the structure and damage level of facilities and equipment to approximate to the actual state).

Flow of Assessment

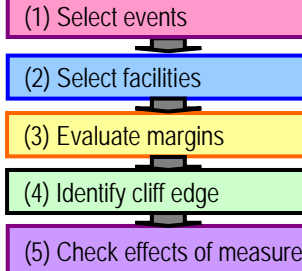

Originating events for reactor assessment

- Loss of offsite power
- Loss of all AC power (station block out)
- Loss of reactor building closed cooling water system
- Loss of DC power
- Anticipated transient without scram
- Loss of control due to loss of instrumentation or control system
- Damage to RPV/PCV
- Damage to reactor building, etc.
- Large-scale leakage of coolant
- Other transient phenomena

Facilities containing safety functions selected for assessments of their safety margins

Situations in which a small increase in a particular aspect of an event such as earthquake or tsunami result in a disproportionate increase in its severity.

The effects of measures to prevent the progress of events causing serious fuel damage.

Outline of Primary Assessment

Event	Cliff edge guideline	Cliff edge value and equipment				Reasons of changes in cliff edge before and after emergency safety measures
		Facility	Unit	After emergency safety measures	Before emergency safety measures	
Earthquake	Margin for design basis earthquake ground motion Ss (Unit 1: 2300 Gal, Unit 7: 1209 Gal)	Reactor core	1	Seismic margin for 2300 Gal is 1.29, PCV stabilizer	Seismic margin of 2300 Gal is 1.29, PCV stabilizer	Emergency safety measures are not reflected in assessments with a scenario that does not anticipate effect mitigation such as damage to RPV or PCV. Before emergency safety measures, the functional loss of the emergency diesel generator caused an SBO and the loss of injection means, but power supply from the power supply vehicle allowed depressurization and injection, improved the margin for the events caused by the loss of offsite power, and changed the cliff edge to a scenario having the next smaller margin. Before emergency safety measures, the functional loss of reactor building closed cooling water system caused the loss of water injection and heat removal means for the spent fuel pool (SFP), but power supply from the power supply vehicle allowed alternative injection means, improved the margin for the events caused by the loss of offsite power, and changed the cliff edge to a scenario having the next smaller margin. The margin of an alternative SFP injection system, which has more orderly procedures, is smaller than that of the emergency diesel generator system, but the margin for the events caused by the loss of offsite power is the same in both systems.
			7	Seismic margin for 1209 Gal is 1.47, reactor base anchor bolts	Seismic margin for 1209 Gal is 1.37, emergency diesel generator	
		Spent fuel pool	1	Seismic margin for 2300 Gal is 1.45, reactor building crane	Seismic margin for 2300 Gal is 1.32, reactor building closed cooling water system	
			7	Seismic margin for 1209 Gal is 1.37, emergency diesel generator	Seismic margin for 1209 Gal is 1.37, emergency diesel generator	
Tsunami	In excess of design height (Units 1 & 7: 3.3m)	Reactor core	1	T.P.15.0m (+11.7m), all equipment in light of conservative assessment	T.P.5.0m (+1.7m), foundation height (SBO)	Before emergency safety measures, tsunami exceeding the foundation height caused an SBO, but water tight doors and other anti-inundation measures will prevent seawater from entering into reactor and turbine buildings even though the tsunami exceeds the foundation height, allowing the power supply and other critical systems to function, and improving the acceptable tsunami height.
			7	T.P.15.0m (+11.7m), all equipment in light of conservative assessment	T.P.12.0m (+8.7m), foundation height (SBO)	
		Spent fuel pool	1	T.P.15.0m (+11.7m), all equipment in light of conservative assessment	T.P.5.0m (+1.7m), foundation height (SBO)	
			7	T.P.15.0m (+11.7m), all equipment in light of conservative assessment	T.P.12.0m (+8.7m), foundation height (SBO)	
Earthquake and tsunami	Same as above for earthquake and tsunami	Reactor core	1	Earthquake: Seismic margin for 2300 Gal is 1.29, PCV stabilizer Tsunami: T.P.15.0m (+11.7m), all equipment in light of conservative assessment	Earthquake: Seismic margin for 2300 Gal is 1.29, PCV stabilizer Tsunami: T.P.5.0m (+1.7m), foundation height (SBO)	Same as the reasons for independent earthquake and tsunami as the event for assessment.
			7	Earthquake: Seismic margin for 1209 Gal is 1.47, reactor base anchor bolts Tsunami: T.P.15.0m (+11.7m), all equipment in light of conservative assessment	Earthquake: Seismic margin for 1209 Gal is 1.37, emergency diesel generator Tsunami: T.P.12.0m (+8.7m), foundation height (SBO)	
		Spent fuel pool	1	Earthquake: Seismic margin for 2300 Gal is 1.45, reactor building crane Tsunami: T.P.15.0m (+11.7m), all equipment in light of conservative assessment	Earthquake: Seismic margin for 2300 Gal is 1.32, reactor building closed cooling water system Tsunami: T.P.5.0m (+1.7m), foundation height (SBO)	
			7	Earthquake: Seismic margin for 1209 Gal is 1.37, emergency diesel generator Tsunami: T.P.15.0m (+11.7m), all equipment in light of conservative assessment	Earthquake: Seismic margin for 1209 Gal is 1.37, emergency diesel generator Tsunami: T.P.12.0m (+8.7m), foundation height (SBO)	
Station block out	Operational time of fuel cooling systems without external support	Reactor core	1	Approx. 12 days (sustained injection time), loss of water source	Approx. 9 hours (sustained injection time), loss of water source	Before emergency safety measures, the loss of freshwater in the condensate storage pool caused the functional loss of the injection system, but power supply from the power supply vehicle restores the circular injection of freshwater from the purified and filtered water tanks, and fire engines allowed the injection of seawater, increasing the sustained injection time. Before emergency safety measures, alternative means were not available for injecting water in the SFP during an SBO, but power supply from the power supply vehicle restored the circular injection of freshwater from purified and filtered water tanks, and fire engines allowed the injection of sea water, increasing the sustained injection time.
			7		Approx. 10 hours (sustained injection time), loss of water source	
		Spent fuel pool	1	Approx. 12 days (sustained injection time), loss of water source	Approx. 4 hours (until pool water reaches 100°C), no injection means	
			7		Approx. 5 hours (until pool water reaches 100°C), no injection means	
Loss of ultimate heat sink		Reactor core	1	Approx. 196 days (sustained heat removing time), loss of fuel in power supply vehicles	Approx. 1.0 day (sustained injection time), loss of water source	Before emergency safety measures, the loss of freshwater in the condensate storage pool and purified water tank caused the functional loss of the injection system, but an alternative heat exchanger system enabled the residual heat removal system to cool down the reactor and SFP.
			7		Approx. 1.2 day (sustained injection time), loss of water source	
		Spent fuel pool	1	Approx. 196 days (sustained heat removing time), loss of fuel in power supply vehicles	Approx. 1.0 day (sustained injection time), loss of water source	
			7		Approx. 1.0 day (sustained injection time), loss of water source	

Earthquake & Tsunami Assessments

The cliff edge for the fuel in reactors and SFPs is identified in the assumption that an earthquake or tsunami, or both exceeding design bases take place.

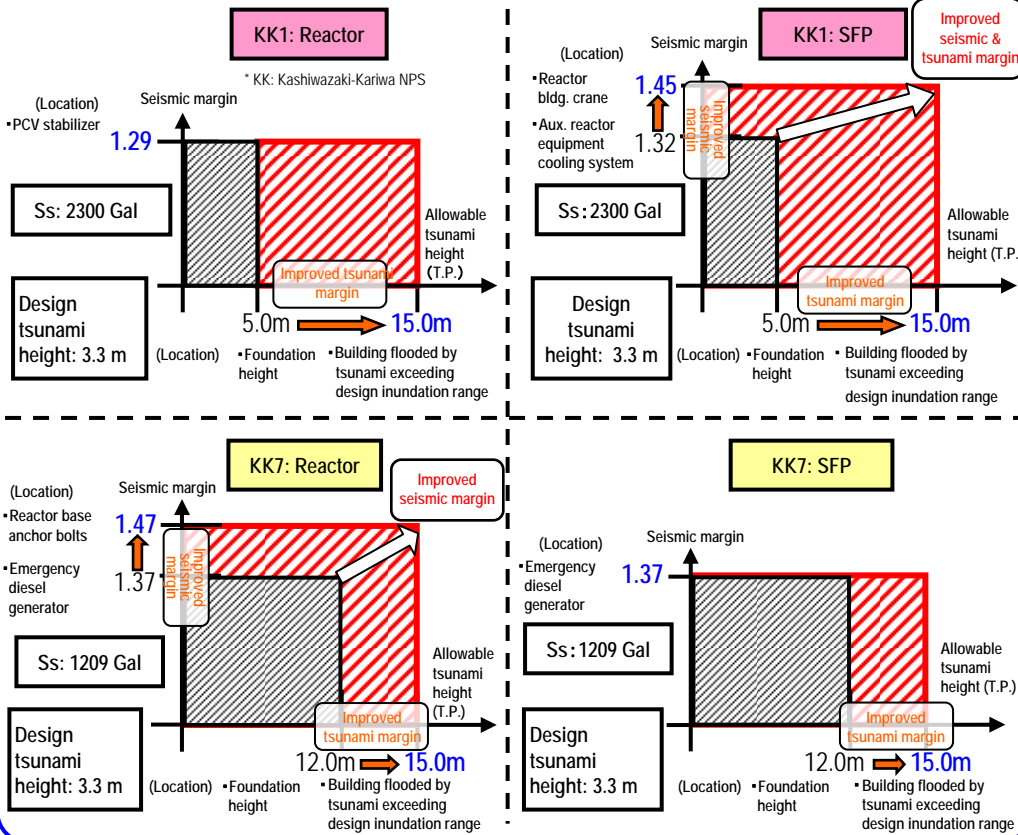

Severe Accident Management

Prevention scenarios were increased when the effects of fuel damage prevention in the severe accident management (AM) measures were evaluated with the originating events assumed in the internal event PSA.

(Example) Unit 1: Fuel damage prevention scenarios with the tripped turbine as the originating event
 Before AM measures: 3 scenarios → After AM measures: 10 scenarios

Conservativeness in Margin Assessment

Earthquake

The identified cliff edge contains the conservativeness based on a certain assumption.

● The following three types of conservativeness are contained in the seismic margin in stress tests, and "functional loss" or "fuel damage" represented under the assessment rules will not occur in reality even though the quake is equivalent to the seismic margin:

(1) Maintainability with a representative point

If the stress at the representative point exceeds the evaluation standard value, "functional loss" is assumed for all of several hundred of piping systems in the pressure boundary.

(2) Maintainability with handling of damage level

"Functional loss" is assumed for the evaluation point exceeding the evaluation standard value regardless of the damage level.

(3) Maintainability with design values

There is a considerable gap between the standard values used in design and the maximum durability causing damage.

● The seismic margin, calculated with Ss in stress tests, depends on the Ss setting, and a large Ss is used at the Kashiwazaki-Kariwa NPS according to the knowledge obtained from the 2007 Chuetsu-Oki Earthquake in Niigata.

Tsunami

● If the water level of tsunami or inundation entering in buildings is higher than the equipment installation level (or installation floor height in light of conservative assessment), functional loss immediately occurs.

● Inundation prevention measures for tsunami of up to T.P. 15.0 m are taken for the reactor building, etc. of Units 1 and 7 at the Kashiwazaki-Kariwa NPS. The tsunami greater than this height is out of the range of inundation prevention measures specification, and presumably causing large-scale floods in the reactor buildings, which makes it difficult to cool or inject water in the reactor or SFP, and results in the functional loss of all installations.

Station Black Out (SBO) and Loss of Ultimate Heat Sink (LUHS)

● A large value is set on the heat to cool (decay heat) to obtain a stern assessment.

● It is assumed that all units of the Kashiwazaki-Kariwa NPS, including #1 and #7, undergo an SBO or LUHS, and have to be taken care of at the same time.

● None of external support is presumed.

SBO

The sustained injection and heat removing time during SBO or LUHS is estimated, the cliff edge identified.

Before emergency measures		After emergency measures	
Reactor	SFP	Reactor	SFP
KK1	9 hours	12 days	12 days
KK7	10 hour	12 days	12 days

Emergency Measures

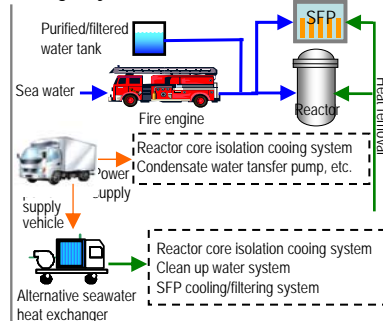

LUHS

Before emergency measures		After emergency measures	
Reactor	SFP	Reactor	SFP
KK1	1.0 day	196 days	196 days
KK7	1.0 day	196 days	196 days

(The figures in the above tables are approximate.)

Summary of Primary Assessment

○ Sufficient safety margins

It was confirmed that even though the event exceeding design basis occurs, safety critical facilities and equipment have sufficient safety margins.

○ Quantitative confirmation of validity of emergency safety measures, etc.

It was confirmed that the emergency safety measures taken thus far, based on the lessons learned from the accident at the Fukushima Daiichi NPS, improved the diversity of safety functions thereby safety itself.

Implementation of Safety Assurance Measures Based on Accident at the Fukushima Daiichi NPS (Stress Test Report, Chapter 6)

<Review of Basic Concept of Safety Assurance Measures>

Based on the lessons learned from the accident at the Fukushima Daiichi NPS, the concept of future safety assurance was defined with four points listed below taken into account including tsunami countermeasures in particular. The relevant measures will be planned according to this concept.

○Flooding protection measures to cope with tsunami

In order to prevent tsunami causing the submergence of safety critical equipment and functional loss, flooding protection measures are taken mainly for reactor buildings. Drainage systems are also provided as a precaution.

○Fuel damage prevention measures during SBO or loss of heat removal functions

Materials and equipment are stored at high places in plant premises to prevent damage to the fuels in reactors and SFPs even during SBO or LUHS (heat removal function), and flexible procedures provided for an effectively use of these materials and equipment.

○Effect mitigation measures provided as a precaution for fuel damage

A top vent is installed for preventing hydrogen explosions following a bare possibility of fuel damage. For ensuring preparations, a filter vent is also installed to mitigate radiation impact on the environment.

○Common measures

Materials and equipment critical for supporting the restoration of reactor facilities following an accident, and a system of using them are provided.

○Fuel damage prevention measures during SBO or loss of heat removal function (1/3)

[Supply of AC power]

Assuring AC power supply in case of failure to provide standard power supply (offsite power/emergency diesel generator)

<< In case of Unit 1 >>

- 1) An emergency M/C (HV switchboard) is installed on a high ground with an air-cooled gas turbine generator car to supply power to the emergency M/C.
- 2) A power supply vehicle is stationed for direct power supply to the emergency M/C or reactor building.
- 3) Procedures, materials and instruments are provided for the direct connection of power supply from the power supply vehicle to safety critical equipment in case of failure to implement 1) and 2) due to the lack of indoor switchboard, etc.

* GTG: Gas turbine generator car
M/C: HV switchboard
P/C: LV switchboard
MCC: LV switchboard

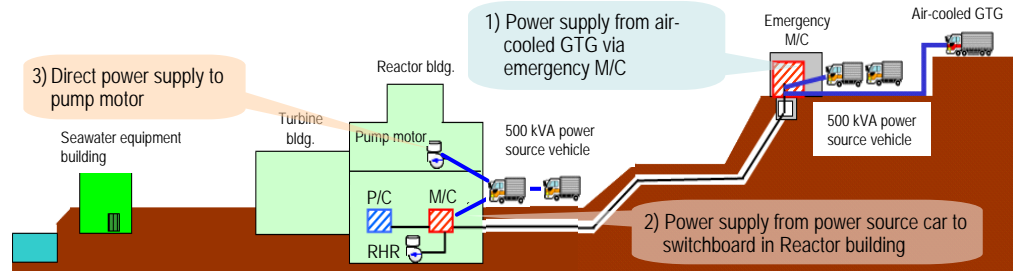

○Flooding protection measures to cope with tsunami

<<In case of Unit 1>>

Measures against tsunami well over the design height

- 1) Tide boards and water-tight outer doors of buildings
- 2) Water-tight inner doors of buildings and waterproof treatment of piping and cable holes
- 3) Drainage pumps in the safety critical equipment areas

[Additional measures] Floodwalls and tide embankments to mitigate the impact of tsunami

1) Floodwall installation

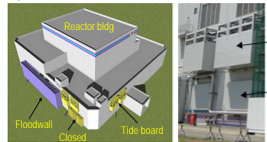

2) Watertight outer doors of building



3) Sump pump

Drainage system is being installed to prevent flooding of safety critical equipment areas.

Drainage

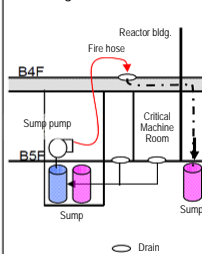

- Floods in equipment areas
- To the sump through drains
- Transferred to other building with a sump pump (to prevent flooding of reactor bldg.)

[Additional measures] Tide embankment installation (Unit 1)

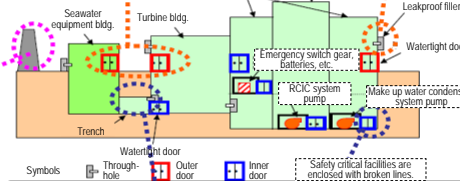
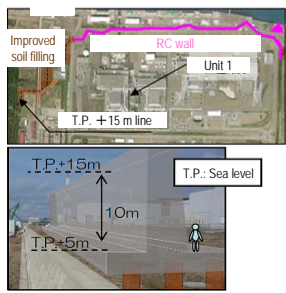

2) Watertight treatment of inner doors and leakproof filler for penetration-holes (e.g., cable tray)

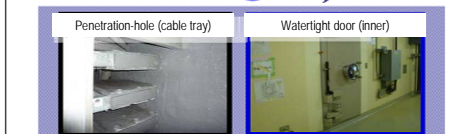

[DC power enhancement]

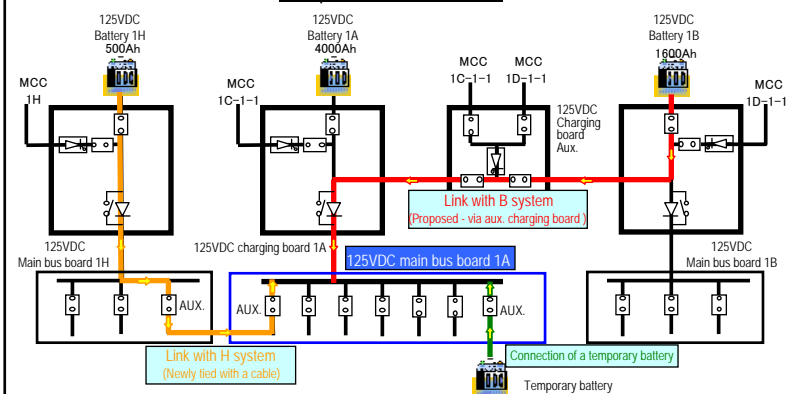

1) A-system DC load is restricted an hour later (e.g., shutdown of plant-vital CVCF), and DC lighting load is disconnected 8 hours later.

2) B-system DC load is restricted an hour later (shutdown of plant-vital CVCF).

3) A- and B-system DC powers are linked 8 hours later, and linked to H-system DC power about 36 hours later.

4) Temporary batteries are applied when the standard battery is used up.

○Fuel damage prevention measures during SBO or loss of heat removal function (2/3)

《In case of Unit 1》

[Water injection in reactor]

HP injection: Various HP injection means with diversified power supply methods

- Reactor core isolation cooling system (RCIC)
- Standby liquid control system (SLC)
- Control rod drive system (CRD)

Various injection means

HP injection method	RCIC	SLC	CRD
Power supply method			
Gas turbine (Emergency MIC)	Yes	Yes	Yes
Power supply vehicle (Power board connection)	Yes	Possible	Yes
Power supply vehicle (Pump motor connection)	-	Under review	-
Battery	Yes	-	-
Manual startup (Electricity not needed)	Yes	-	-

Yes: Water can be supplied

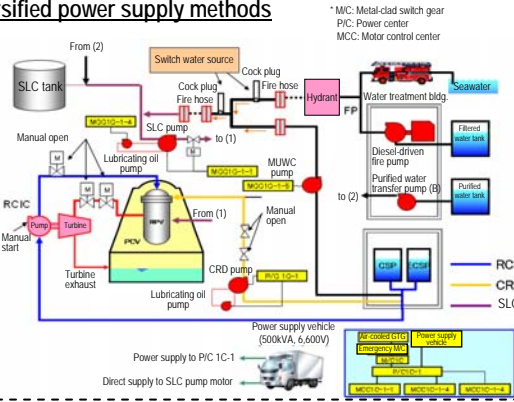

LP injection: Various LP injection means with diversified power supply methods

- Make up water condensate system (MUWC)
- Diesel-driven fire pump (D/DFP) (Can be used without electricity)
- Fire engine (Can be used without electricity)

Various injection means

LP injection method	MUWC	D/DFP	Fire engine
Power supply method			
Gas turbine (Emergency MIC)	Yes	Yes (Operable without electricity)	Yes (Operable without electricity)
Power supply vehicle (Power board connection)	Yes	-	-

Yes: Water can be injected.

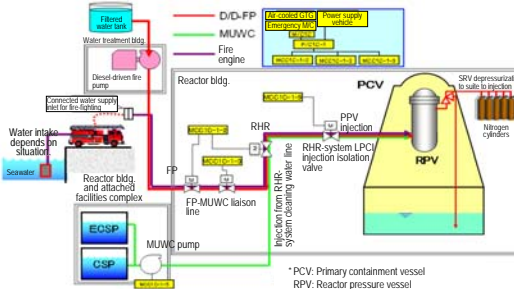

[Depressurization]

The safety relief valve (SRV) is opened to depressurize the reactor.

- Spare nitrogen cylinders are provided in addition to the standard cylinders to supply compressed air for opening the valve.
- The battery is provided as an alternative means if the power for operating the SRV is lost.

Opening SRV using a battery

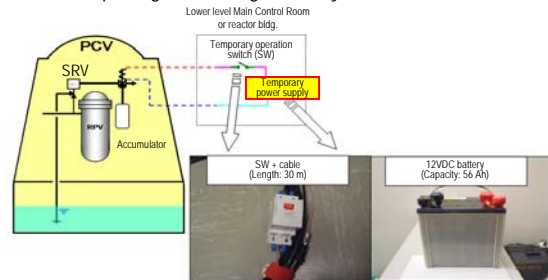

Opening SRV using a spare cylinder

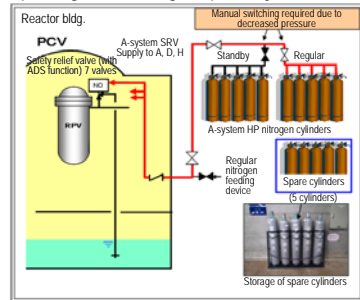

[Removal of reactor residual heat] Various means for power supply, heat removal from reactors and heat release into the ocean

Power supply

- Power supply vehicle
- Air-cooled gas turbine generation car (air-cooled GTG)

Heat removal

- Residual heat removal system (RHR)^{*1}
- Clean up water system (CUW)

Heat release to the ocean^{*2}

- Alternative heat exchanger
- Alternative undersea pump

*1 Use air-cooled GTG for RHR.

*2 Supply seawater to RHIW. Connect RHIW and RIW with a tie-line.

Heat removal using an alternative undersea pump/heat exchanger and CUW

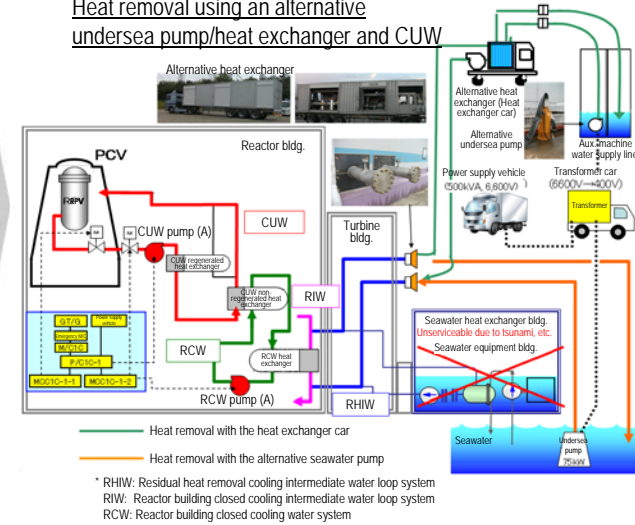

[Water injection into the spent fuel pool (SFP) and heat removal]

Injection: Various injection means with diversified power supply methods

Various injection means

SFP injection method	FPMUW	MUWC	D/DFP	Fire engine (seawater, via FP)	Fine engine (sea water, hose)
Power supply method					
Gas turbine (Emergency M/C)	Yes	Yes	-	Yes (Operable without electricity)	-
Power supply vehicle (Power board connection)	Yes	Yes	-	-	-
No electricity	-	-	-	-	-

Heat removal: Various means for power supply, heat removal from SFP and heat release into the ocean

Heat removal using an alternative undersea pump/heat exchanger and FPC

Power supply

- Power supply vehicle
- Air-cooled gas turbine generation car (air-cooled GTG)

Heat removal

- Residual heat removal system (RHR)^{*1}
- Fuel pool cooling & filtering system (FPC)

Heat release to the ocean^{*2}

- Alternative heat exchanger
- Alternative undersea pump

*1 Use air-cooled GTG for RHR.

*2 Supply seawater to RHIW. Connect RHIW and RIW with a tie-line.

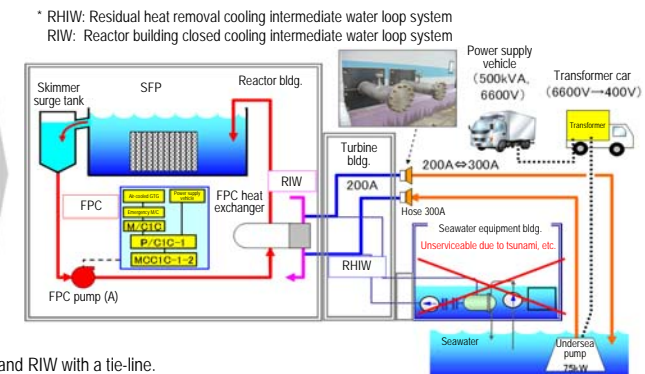

○ Fuel damage prevention measures during SBO or loss of heat removal function (3/3)

《In case of Unit 1》

[Vent operation]

The vent is operated to release the pressure and heat when the PCV is likely to be damaged. To ensure the vent operation:

- Spare air cylinders are provided for operating the vent valve.
- Tools for manual valve operation are provided with a procedure for manual operation.

Measures for improving the reliability of the vent line, and the operation of the vent at a specified time are under discussion.

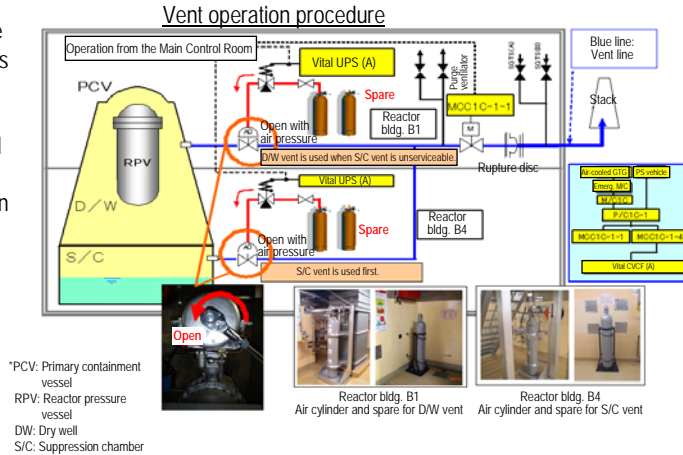

*PCV: Primary containment vessel
RPV: Reactor pressure vessel
DW: Dry well
S/C: Suppression chamber

* The location of manual operation of the vent is isolated from the PCV by a concrete wall which may protect the operator from radiation exposure.

[Transfer of fuel and stored water]

1. Transfer from filtered/purified water tank

- 1) MUWP pump is connected to the generator to supply water from the purified water tank to the CSP.
- 2) Water is supplied to ECSP from the filtered water tank via the diesel-driven fire pump.

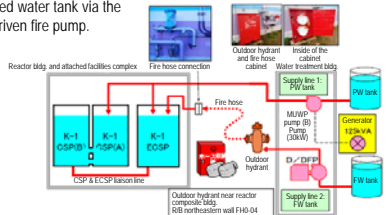

2. Reservoir

A reservoir is provided at a high place in the plant premises to store sufficient amounts of freshwater required to fill the condensate storage pool (CSP) and freshwater tank if the heat removal functions are not restored in the whole plant. Water is transferred from the reservoir to the relevant water tanks via a natural flow system without using motors. The whole installation is located on the stable ground not affected by earthquakes and free from the onslaught of tsunami.

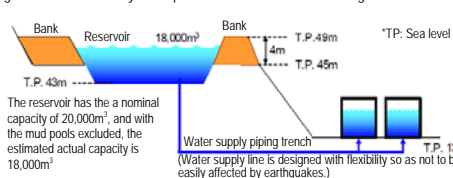

3. Transfer of fuel from light oil tanks to fire engines and power supply vehicles with a mini tank lorry

The fuel is supplied to the power supply vehicles, fire engines and air-cooled gas turbine generator vehicles from the light oil tanks with the transportable light oil pump stored at the high place in the premises and mini tank lorry.



An agreement has been made with contractors to get fuel from the local regions and Kanto area in an emergency.

4. Underground light oil tanks

Gas turbine vehicles have been deployed at a high place in the plant premises to generate electricity in the event of SBO, and underground tanks store fuel for power generation.

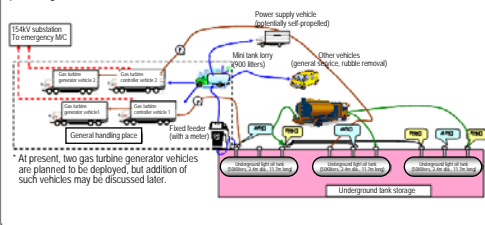

○ Impact mitigation measures provided as a precaution for fuel damage

《In case of Unit 1》

Hydrogen accumulation prevention measures (ventilation of reactor building)

A ventilation system is installed to release hydrogen leaked in the reactor building.

- 1) An opening is provided at the top of the reactor building that can be manually operated (top vent), and the procedure to manually open the blow out panel is provided.
- 2) A hydrogen sensor is installed near the top vent to detect hydrogen accumulated in the building.

PCV pressure and temperature rise prevention measures (cooling of PCV)

If fuel damage is anticipated, spraying water to the dry-well and suppression chamber from an external water source will curb the rise of pressure and temperature of the PCV.

Filter vent

A filter vent is installed for reducing the amount radioactive materials released in the air.

Facilities to prevent hydrogen accumulation

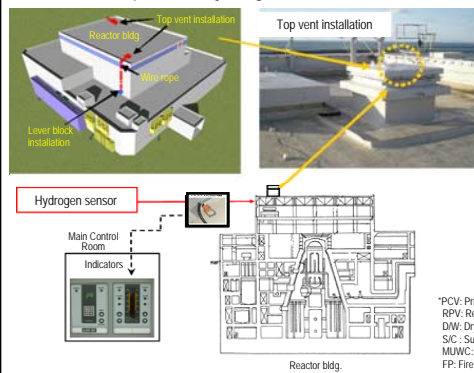

Cooling of PCV

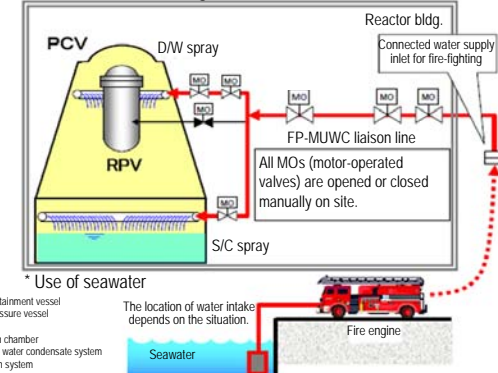

○ Common measures (1/2)

Measuring and monitoring instruments

- 1) The spent fuel pool (SFP) monitoring system is available regardless of the changes in the water level.
- 2) A SFP monitoring camera and a remote controller are installed.
- 3) Procedures to monitor plant parameters using a battery, data recorder, etc. are developed.
- 4) A system for transmitting digital recorder data via the common LAN in the plant premises is implemented to improve data confirmation functions at the Technical Support Center.

- 1) SFP heat gauge
- 2) Monitoring camera
- 3) Connection of instruments to battery
- 4) Digital recorder remote monitoring system

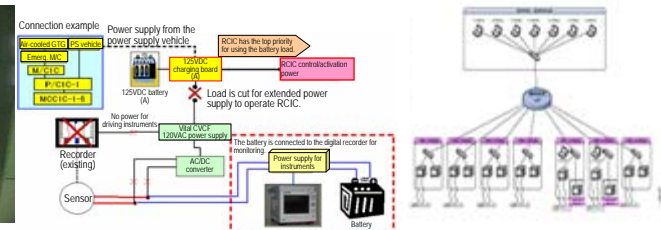

○Common measures (2/2)

Improvement of the emergency response system

- Local ventilators and adhesive mats are installed as measures to suppress the contamination and dose increase in the Main Anti-Earthquake Building, and the entrance doors and hatches of the building were made water-tight to prevent inundation.
 - Procedures for recirculation of the air-conditioning system are set to improve the workspace (dose suppression) in the Main Control Room following the loss of power.
 - The communication system was improved by reinforcing power supply to the PHS switchboard and the paging system, introducing transportable PHS antennas, and providing mobile radio equipment.
 - Heavy machines were deployed in the plant premises for removing rubbles immediately from the passage ways.
 - Full-face masks, charcoal filters and other protective gears were stored to ensure the safety of workers engaged in restoration operation.
 - The emergency response system was improved (assignment of workers to various emergency work).
 - The number of monitoring cars for checking outdoor radiation levels was increased and the power supply to the Environment Control Building was increased with more transportable generators.
- For ensuring the exposure dose management, APD (alarmed pocket dosimeters), integrating dosimeters, radiation measuring instruments and materials were increased.
- In the emergency workforce, the radiation protection staff is planned to be increased to ensure sufficient manpower for radiation control.
- Generators were installed at the monitoring posts to prevent failure to measure radiation in case of the power loss.
 - Various training courses including nighttime training, simultaneous response training at multiple plants, and other practical trainings have been conducted.

4) Heavy machines for removing rubble



7) Monitoring car



○Continuous improvement of safety

At the Kashiwazaki-Kariwa NPS, multi-faceted efforts were made including the establishment of comprehensive tsunami countermeasures, reactor damage prevention measures, and impact mitigation measures. In light of increasing the safety, various means are scrutinized to make these measures more comprehensive, and based on the knowledge obtained in Japan and abroad in the future, further enhancement of safety will be discussed to promote continuous improvement.

Instrumentation design to maintain sufficient monitoring function in a severe environment

When the accident occurred at the Fukushima Daiichi NPS, the parameters required for taking action were difficult to obtain over time. It is critical to improve the reliability of monitoring function to accurately understand various parameters required for taking actions in a severe environment caused by the damaged reactor.

→ Development of an instrumentation system on the assumption of operation in a severe accident environment.

(Example: Thermocouple for monitoring water level in the RPV)

Diversification of cooling means without the need for AC power

If a station black out occurs, immediate high pressure water injection is essential. Accordingly, the reliability of the reactor core isolation cooling system which is not required AC power was improved.

→ For further improvement in safety, diversified cooling means which do not require AC power will be examined.

○Measures, implementation state and classification

《In case of Unit 1 (Units 1 and 7 mostly use same measure).》

Measures based on accident at Fukushima Daiichi NPS		Description	State	Classification
Protection against tsunami	1. Tsunami	(1) Watertight and leaktight treatment of buildings and facilities	Completed	E/A
		(2) Floodwall	In progress	A
		(3) Tide embankment	In progress	A
		(4) Safety relief valve (battery driven)	Completed	A
Fuel damage prevention during SBL or LUHS	2. Power supply	(1) Power supply vehicle	Completed	E
		(2) Air-cooled GTG, emergency metal-clad	Completed	A
		(3) DC power supply enhancement (battery, etc.)	In progress	A
	3. HP injection	(1) Standby liquid control system (SLC) (Power supply from power supply vehicle, etc.)	Completed	E
		(2) Control rod driving system (CRD) (Power supply from power supply vehicle, etc.)	Completed	A
		(3) Reactor core isolation cooling system (RCIC), manual startup	Completed	A
	4. Depressurization (safety relief valve)	(1) Safety relief valve (cylinder driven)	Completed	E
		(2) Safety relief valve (battery driven)	Completed	A
	5. LP injection	(1) Make up water condensate system (MUWC) (Power supply from power supply vehicle, etc.)	Completed	E
		(2) D/DFP (system makeup with power supply from power supply vehicle, etc.)	Completed	E
(3) Fire engine (seawater)		Completed	E	
(4) Safety relief valve (battery driven)		Completed	A	
6. PCV vent	(1) Acquisition of the PVC vent valve driving source	Completed	E	
	(2) Manual opening of the vent valve	Completed	A	
7. Heat removal from RPV	(1) Heat removal using an alternative seawater heat exchanger	Completed	A	
	(2) CUW heat removal using an alternative seawater pump	Completed	E	
8. SFP injection	(1) Injection using D/DFP	Completed	E	
	(2) Fire engine (seawater, fire extinguishing system)	Completed	E	
	(3) Fire engine (seawater, fire hose)	Completed	A	
9. SFP heat removal	(1) FPC heat removal using an alternative seawater pump	Completed	E	
	(2) Fuel transfer from light oil tanks to fire engines and power supply vehicles with a mini tank lorry	Completed	E	
10. Fuel and water storage	(3) Freshwater reservoir	In progress	A	
	(4) Underground light oil tanks	In progress	A	
	(1) R/B top vent	Completed	SA/A	
	(2) Cooling of PCV	Completed	A	
Impact mitigation following fuel damage	(3) Hydrogen sensor	Completed	A	
	(4) PCV filter vent	Planning	-	
	12. Measuring and monitoring instruments	(1) SFP water level gauge	Completed	A
		(2) SFP monitoring camera	Completed	A
(3) Acquisition of power supply for the Main Control Room instruments		Completed	A	
(4) Digital recorder remote monitoring system		Completed	-	
Common measures	13. Enhancement of emergency response systems	(1) Improvement of workspace in the Technical Support Center	In progress	A
		(2) Improvement of workspace in the Main Control Room	Completed	SA
		(3) Improvement of communications	In progress	SA/A
		(4) Removal of rubble	Completed	E/SA/A
	(5) Supply of equipment	Completed	SA/A	
	(6) Emergency response system	Completed	-	
	(7) Radiation protection	In progress	A	
	(8) Monitoring posts	Completed	E	
	(9) Rules of training (e.g., frequency)	Completed	-	
14. Continuous improvement of safety	○ Discussion about RPVs and PCV measuring system that can be operational in a severe environment	Discussed in future	-	
	○ Various cooling means without the need of AC power	Discussed in future	-	

(E: Emergency safety measures, SA: Measures for severe accident, A: Additional safety improvement measures)