

Detection of Xe135 at Nuclear Reactor of Unit 2,
Fukushima Daiichi Nuclear Power Station

November 4, 2011
Tokyo Electric Power Company

On November 1, as a sampling result by the gas control system that we have newly installed for Unit 2, some Xe135, a nuclear fission product, was detected. Considering its short half-life (around 9 hours), it was produced by a recent nuclear fission, not produced before the March 11. Even though a nuclear reactor is not in a critical state, a very small amount of nuclear fission always happens. The Xe135 was detected as a result of the introduction of a high-sensitive measuring method. There existed a concern that a fission reaction occurred with nuclear fuels in Unit 2, however, we have decided the fuel is not in a critical state for the following reasons:

(1) The detected Xe135 level is low

In a normal nuclear reactor that has no neutrons, nuclear fissile materials are produced and they bring about a small amount of fission (spontaneous fission) even if the reactor is sufficiently cooled down.

Taking into account the value of spontaneous fissile materials in nuclear reactors, we calculated the amount of the Xe135 produced by spontaneous nuclear fission and it basically coincides with the density of Xe135. (Document 1)

Moreover the detected amount of Xe135 was very small when compared with that which is produced in a normal critical state. (Document 2)

We decided consequently the Xe135 detected this time was a product of “spontaneous nuclear fission”.

Although we have also detected Xe133, a 5-days half-life, we took Xe135 that is shorter in half-life period and is obviously a product of the recent nuclear fission.

(2) Xe135 was detected even after injecting borate acid

If a nuclear reactor were in a critical state, fission chain reactions would stop by injecting the borate acid. However, even after the injection of borate acid, the same value of Xe135 as detected on November 1, remained detectible. (Document 3)

It follows that this time some Xe135 by “spontaneous nuclear fission” was detected that arises regardless of the borate acid around it.

(3) No significant change in the reactor parameters

We are continuously measuring the pressure values in various parts to know the status of reactors and pressure vessels. Once there is a critical state, we are supposed to detect some changes in the parameters before or after November 1. However, we didn't see any significant changes in the parameters and the temperature at the bottom of nuclear reactor lowered as the amount of injected water decreased. (Document 4)

The radiation effect by the spontaneous fission is negligible. (Document 5)

Xe135 density comparison of spontaneous fission and actual measurement

1. Presumed radioactive density of the Xe135 by spontaneous fission

Even in a non-critical (shut down) state, a nuclear reactor usually has spontaneous fissile nuclides in it. Well-known are Cm-242 and Cm-244, and currently in Nuclear Reactor of Unit 2, the fission is as follows:

Cm242: 8.3E8 times/sec
 Cm244: 7.4E8 times/sec (Appendix 1-1)

We don't take into consideration the nuclear fission caused by the U-235 absorption of neutron. This is an evaluation conservative enough to show that the Xe135 detected this time was produced in a non-critical state.

Although Xe135 is also produced by Xe134 (n, γ) reaction, we don't evaluate it due to the presumably small contribution. (Appendix 1-2)

Yield of Xe135 produced by Cm-242: 2.66% Generation speed: 2.2E7 p/sec

Yield of Xe135 produced by Cm-244: 1.22% Generation speed 9.0E6 p/sec

That follows in total: 3.1E7 p/sec

(Source : Fission product yields, <http://www-nds.iaea.org/wimsd/fpyield.htm#T5>)

As the present gaseous phase volume of the reactor vessel is 3,000 m³ (Appendix 2), and the amount of injected N₂ is 4m³/h, it takes 214 hours to fully ventilate.

The amount of spontaneous fission is steady. On the other hand, because the amount of the injected N₂ from September to October is 14 m³/h, varying little, we think the amount of Xe135 in Nuclear Reactor is well balanced as the following formula illustrates:

$$\text{Yield of Xe135 per second} = \lambda \cdot N + 1.4 \cdot N / (3000 \times 3600)$$

λ : Xe135 decay-constant (2 . 1 2 E - 5)

N : Number of Xe135 atoms in Nuclear Reactor

$$\begin{aligned} 3.1E7 &= 2.12E-5 \times N + 1.3E-6 \times N \\ N &= 1.4E12 \text{ particles} \end{aligned}$$

Nuclide density of Xe135 in Nuclear Reactor per 1cc

$$\begin{aligned} & N / (3000 \times 1 E 6) \\ = & 2 . 1 2 E - 5 \times 1 . 4 E 1 2 / (3000 \times 1 E 6) \\ = & \underline{9 . 9 E - 3 \text{ Bq / c c}} \end{aligned}$$

2. Xe135 Radioactive density measured in the primary containment vessel

Xe135 Radioactive density was measured from the charcoal filter, which was installed in the gas management system, is 1.7E-5 Bq/cc.

Collection efficiency of the charcoal filter is 1566 times as determined from the ratio of the value measured in the charcoal (5.3E-1 Bq/cc) and the value measured in a vial.

Thus, the density of the Xe135 Radioactive in the primary containment vessel, obtained from the measurements, is

$$\begin{aligned} & 1 . 7 E - 5 \times 8 . 3 E 2 / 5 . 3 E - 1 \\ = & \underline{2 . 7 E - 2 \text{ Bq / c c}} \end{aligned}$$

3. Conclusion

The density of the Xe135 Radioactive in the primary containment vessel, obtained from the measurements, is the same order of the Xe135 density estimated to result from the spontaneous fission of Cm.

Therefore, Xe135 detected this time, arose from spontaneous fission of Cm.

End

Amount of Xe135 generated in the critical state of 1kW

Starting at BWR, output level of the first critical is a few kW (Figure 1). This paper estimate the amount of Xe135 generated in the critical state of 1kW.

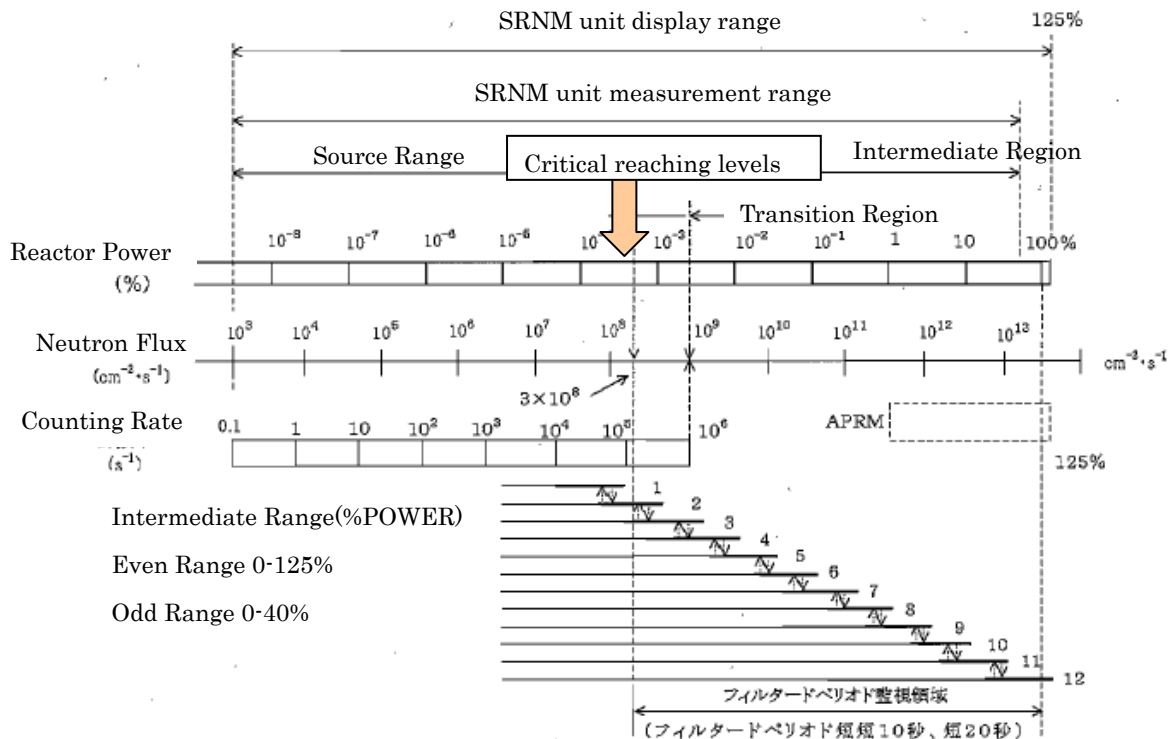

Figure 1. Monitoring Instruction Range on Start-up Area

The energy generated from single nuclear fission is about 200MeV. Thus 1kW output is equivalent to the fission of $3.1 \text{ E}13$ per second.

From the fission yield (6.5%) of Xe135, The generation rate of Xe135 is $2\text{E}12$ per second.

Next, we derive the radioactivity concentration of Xe135 in the primary containment vessel in the case that Xe135 generates $2\text{E}12$ per second.

Because the generation of fission is constant, and the injection amount into the primary containment vessel of N2 during September and October is not changed significantly, the amount of Xe135 in the primary containment vessel become collapse equilibrium state by the following formula.

Xe135 Generation amount per second

$$= \lambda \cdot N + 14 \cdot N / (3000 \times 3600)$$

λ : Decay constant of Xe135(2.12E-5)

N : Number of Xe135 atoms in the primary containment vessel

$$\begin{aligned} 2.12 \times 10^{-5} N + 1.3 \times 10^{-6} N \\ N &= 8.9 \times 10^{16} \end{aligned}$$

Radioactivity concentration per 1cc of Xe135 in the primary containment vessel is

$$\begin{aligned} \lambda N / (3000 \times 10^6) \\ &= 2.12 \times 10^{-5} \times 8.9 \times 10^{16} / (3000 \times 10^6) \\ &= \underline{\underline{630 \text{ Bq/cc}}} \end{aligned}$$

Collection efficiency of the charcoal filter is derived from the ratio of the charcoal filter measurement (5.3E-1 Bq/cc) of Kr85 and the measurement (8.3E2 Bq/cc) in a vial. Then, the radioactivity concentration per 1cc of Xe135 at the charcoal filter is:

$$\begin{aligned} 630 \times 5.3 \times 10^{-1} / 8.3 \times 10^2 \\ &= \underline{\underline{0.4 \text{ Bq/cc}}} \end{aligned}$$

If the Unit 2 fuel is in the critical state, Xe135 concentration is observed 4 orders of magnitude larger than current level. Therefore, present state is not considered critical.

End

Gas sampling evaluation result in the Unit 2 PCV gas management system

(1) Iodine holder analysis result in the dust sampling equipment

Date of Sampling	November 1		November 2
Measurement date	November 1	November 2	November 2
Nuclide(Half-life)	Concentration in the gas collected (Bq/cm ³)		
Cs-134(2 years)	4.6×10 ⁻⁶	N.D. (<3.8×10 ⁻⁶)	7.9×10 ⁻⁶
Cs-137(30 years)	6.6×10 ⁻⁶	5.3×10 ⁻⁶	N.D. (<4.0×10 ⁻⁶)
Kr-85(11 years)	4.4×10 ⁻¹ □	3.6×10 ⁻³ □	5.3×10 ⁻¹ □
Xe-131m(12 years)	6.9×10 ⁻⁴ □	5.3×10 ⁻⁴ □	6.1×10 ⁻⁴ □
Xe-133(5 days)	1.4×10 ⁻⁵ □ (>1.3×10 ⁻⁵)	6.5×10 ⁻⁶ □ (>3.4×10 ⁻⁶)	N.D. □ (<1.5×10 ⁻⁵)
Xe-135(9 hours)	1.2×10 ⁻⁵ □ (>4.1×10 ⁻⁶)	1.3×10 ⁻⁵ □ (>5.4×10 ⁻⁶)	1.7×10 ⁻⁵ □ (>4.3×10 ⁻⁶)
I-131 (8 days)	N.D.(<4.2×10 ⁻⁶)	N.D. (<1.8×10 ⁻⁶)	N.D. (<4.4×10 ⁻⁶)

□ Assuming that the capture rate of rare gas to charcoal filter is 90% as same as Iodine.

(2) Gas analysis result at the filter inlet and outlet of PCV gas management system

Place of Sampling	Inlet of the filter	Inlet of the filter	Outlet of the filter
Measurement date	October 28	November 2	November 2
Nuclide(Half-life)	Concentration in the gas collected (Bq/cm ³)		
Cs-134(2 years)	1.1	8.4×10 ⁻¹	1.5 *
Cs-137(30 years)	1.7	9.6×10 ⁻¹	1.7 *
Kr-85(11 years)	N.D.	N.D.	8.3E2
Xe-131m(12 years)	N.D.	N.D.	N.D.
Xe-133(5 days)	N.D.	N.D.	N.D.
Xe-135(9 hours)	N.D.(<1.6×10 ⁻¹)	N.D.	N.D.
I-131 (8 days)	N.D.(<2.1×10 ⁻¹)	N.D.	N.D.

* Since the value in outlet is higher than in inlet, they are as a reference.

Note: There is a possibility that the gas collected in the inlet filter contain iodine, but because iodine nuclides decayed, and no other nuclides decay. Thus, It is considered that the measurement in the inlet filter is below the detection limit due to high background level. In addition, it is considered that the measurement of I-131 in the outlet filter is below the detection limit due to adsorption of charcoal filter.

Transition of Unit 2 plant parameters

Transition of air dose rate of Portable MP (South of administrative building)

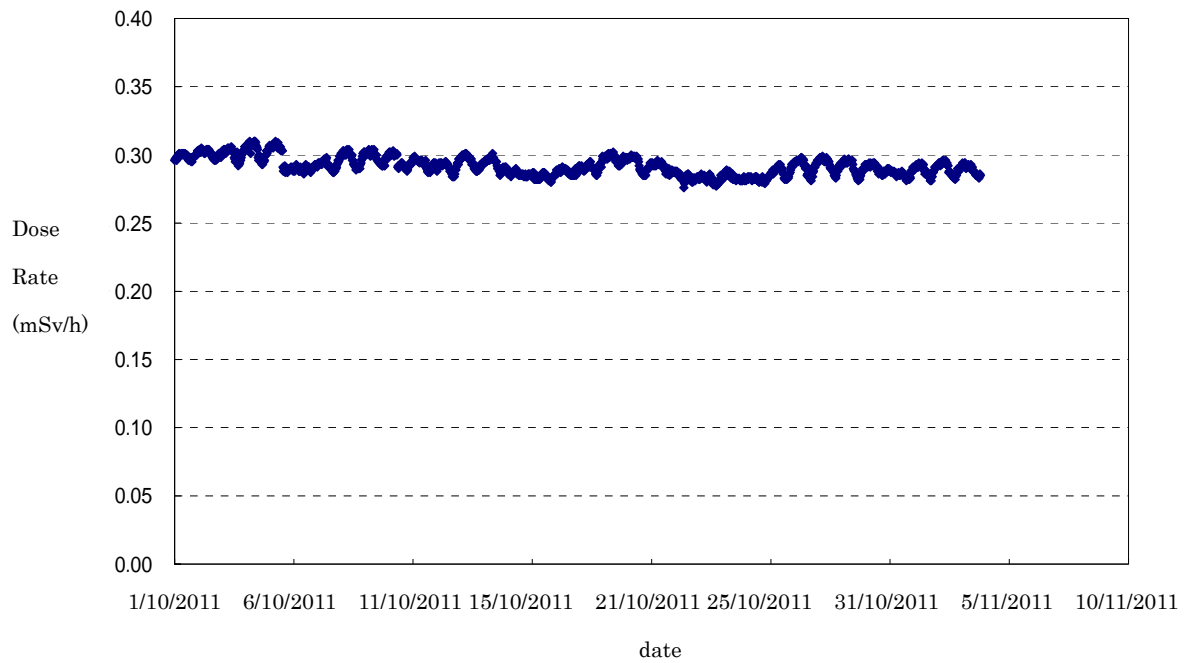

2u

Reactor Pressure, D/W Pressure (for monitoring CS switch)

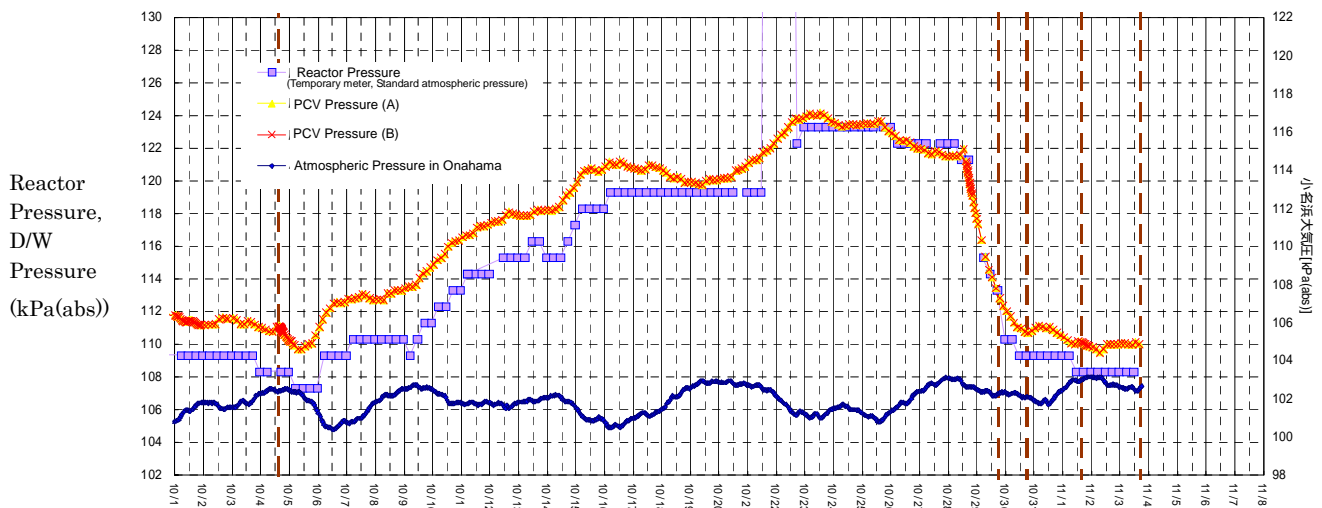

2u

Temperature

1F-2 representative point temperature around 1F-2 RPV

As of 19:00 3/11/2011

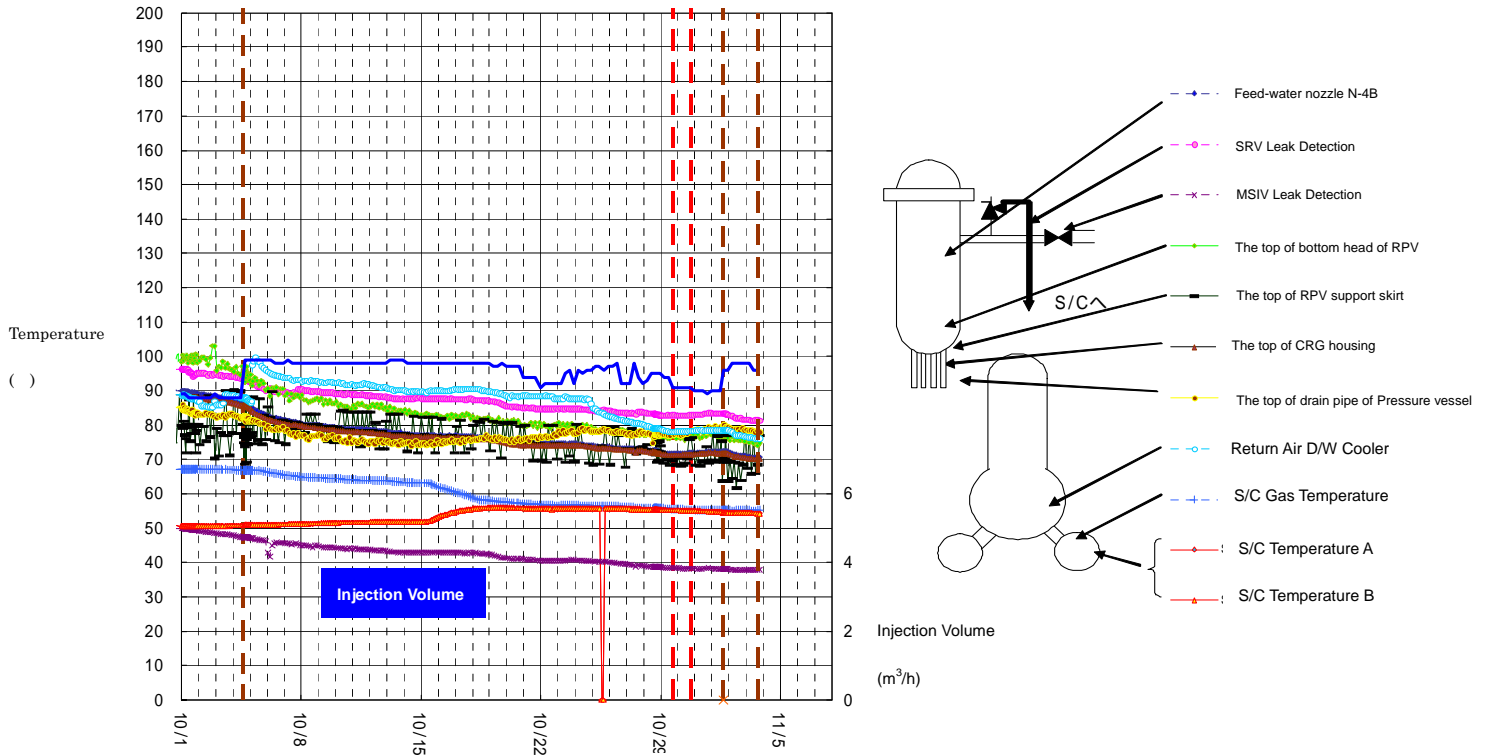

Significant decline of flange lid of the RPV is due to measurement system failure (confirmed on Sep. 20)

**Result of Exposure Assessment to Noble Gases released from the Gas Management
System of unit 2 Primary Containment Vessel**

The exposure assessment was conducted from the measurements of the outlet gas of the gas management system of unit 2 primary containment vessel. We used the relative concentration used to accident safety evaluation, and the evaluation was calculated assuming continuous emission at this concentration for one year.

As for the radioactivity concentration at the outlet of PCV gas management system, the trapping factors were conducted from measurement result taken at the charcoal filter and the measurement result from gas, the radio activity assessment was determined by multiplying each nuclide with the tapping factors.

As a result, the annual dose at the site boundaries is approximately 0.0001mSv at maximum, so that the annual dose is estimated to be low enough compared to the legal dose limitation (1mSv / year).

In addition, It is low enough compared to the evaluation value of the annual dose to cesium from the primary containment vessels of Unit 1-3 (approximately 0.2mSV / year, as of October 17)

(Calculation Result)

Detected Nuclide	Measurement Data Channel Filter (Nov. 2)	Trapping Factor	Evaluation Value of Radioactivity	Ventilati on Flow	Gamma-ra y Effective Energy	Relative dose (0.5MeV rate)D/Q	Off-site Effective dose (Maximum)	
	Concentration (Bq/cm3)						m3/h	MeV
Kr-85	5.3E-01	1.6E+03	8.3E+02	14	0.0022	2.4E-19	1.1E-01	
Xe-131m	6.1E-04	1.6E+03	9.5E-01	14	0.02	2.4E-19	1.1E-03	
Xe-133	-	1.6E+03	-	14	0.045	2.4E-19	-	
Xe-135	1.7E-05	1.6E+03	2.7E-02	14	0.25	2.4E-19	4.0E-04	
Total							0.11	μ Sv / year
(Calculation Formula)							0.00011	mSv / year

Off-site Effective Dose(μ Sv / year)=Evaluation Value of Radioactivity × 10⁶ × Ventilation Flow

× Gamma-ray Effective Energy / 0.5(MeV) × Relative Dose × 10⁶ × 8760(hours / year)

End

Table 1 The ORIGEN calculation result on the number of Neutrons generated by spontaneous fission

(Unit : the number of Neutrons / sec / The initial weight of Uranium 1t)

Nuclide	U-238	Pu-238	Pu-240	Pu-242	Cm-242	Cm-244	Cm-246
After 120 days of cooling	1.20E+04	1.21E+05	1.35E+06	2.25E+05	4.99E+07	2.42E+07	2.97E+04
After 365 days of cooling	1.20E+04	1.25E+05	1.35E+06	2.25E+05	1.76E+07	2.36E+07	2.97E+04

Analysis Condition : ORIGEN

Uranium Fuel STEP3B type Initial U-235 Concentration 3.80wt%

Specific Power 25.52 MW/t

Rated Thermal Output 2381MWth

Combustion Calculation up to 23.2GWd/t, Reactor core average burnup during the earthquake outage / Decay Calculation over 23.2GWd/t

Table2 The Number of spontaneous fission of Cm-242 and Cm-244 in 1F-2

	Cm-242	Cm-244
After 120 days of cooling (Num. of Fission/sec)	1.348E+09	7.526E+08
After 365 days of cooling (Num. of Fission/sec)	4.765E+08	7.336E+08

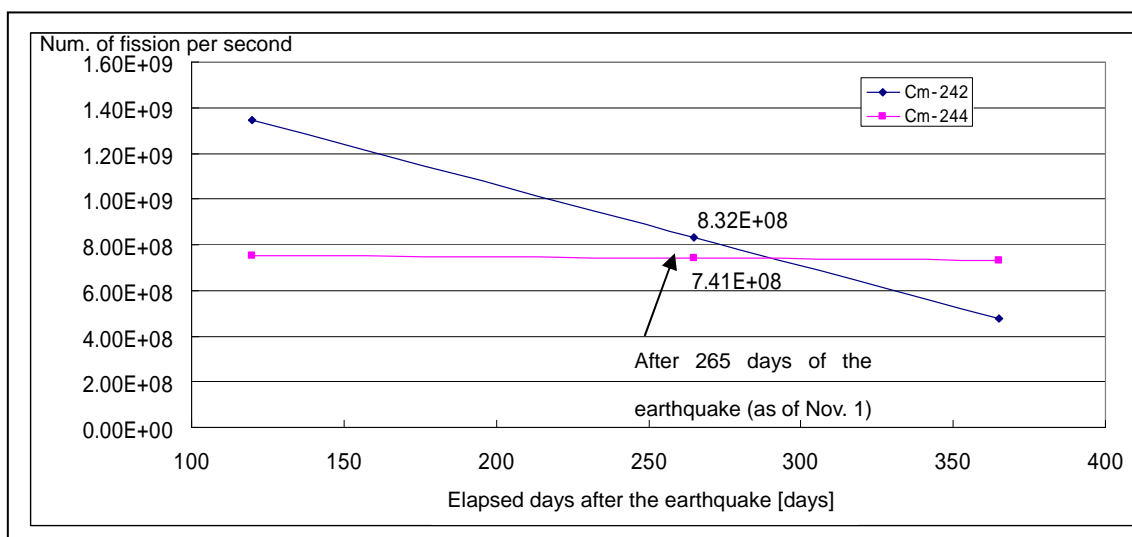

Generation of Xe135 caused by the (n, γ) reaction of Xe134

1 . Introduction

Generation of Xe135 is known to be caused by (n, γ) reaction of Xe134 other than by spontaneous fission. Here, we examined how the generation of Xe135 caused by the (n, γ) reaction of Xe134 would significantly contribute to the concentration increase in Xe135.

2 . Evaluation and consideration

Yield for Xe134 is 7.8% which is considered to be relatively high. In addition, the amount of Xe134 remained in the reactor is considered to be large among noble gas because Xe134 is stable nuclide and has no attenuation.

Kr-85 with half-life period of 10 years is currently detected from primary containment vessel approximately $4 \times 10^{-1} \text{Bq/cm}^3$ (equivalent to $10^8/\text{cm}^3$ in atomicity) . However, factoring in that Xe134 is stable nuclide when compared to this as well as its large yield, the concentration is considered to be approximately one digit larger than Kr-85.

As for the absorption of neutron for (n, γ) reaction, absorption cross-section for Xe134 is shown in figure 1. When compared to Xe131 which is considered to have large absorption cross-section (figure 2), absorption cross-section is approximately few digits smaller and it can be concluded that it is not particularly the nuclide with significant neutron absorption.

Also, because it is noble gas, Xe134 is liberated from fuel inside the primary containment vessel and neutron density at gas phase apart from the fuel is low. Therefore, (n, γ) reaction is not considered to occur lively.

3 . Conclusion

Even though Xe134 is considered to possess large amount of atoms compared to other kinds of noble gas, the generation of Xe135 by (n, γ) reaction is assumed to be small from the facts that absorption cross-section for neutron is small and neutron density is low.

End

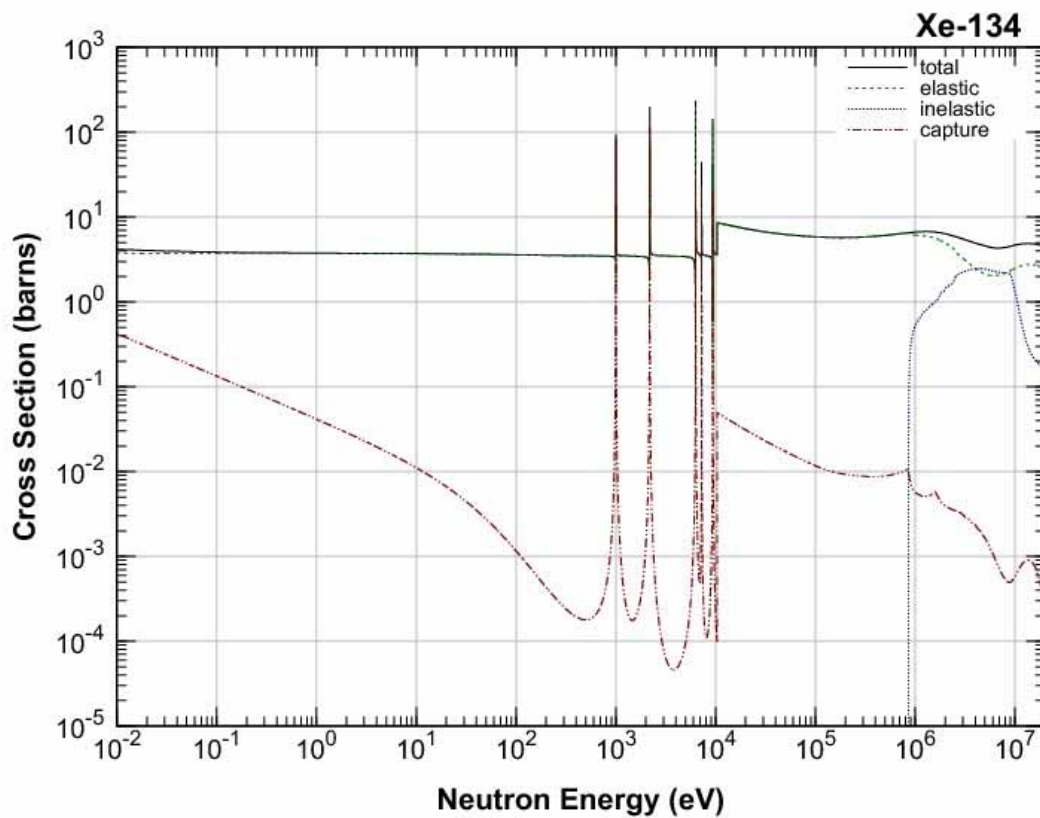

Fig.1 Reaction cross-section for Xe134 (JENDL4.0)

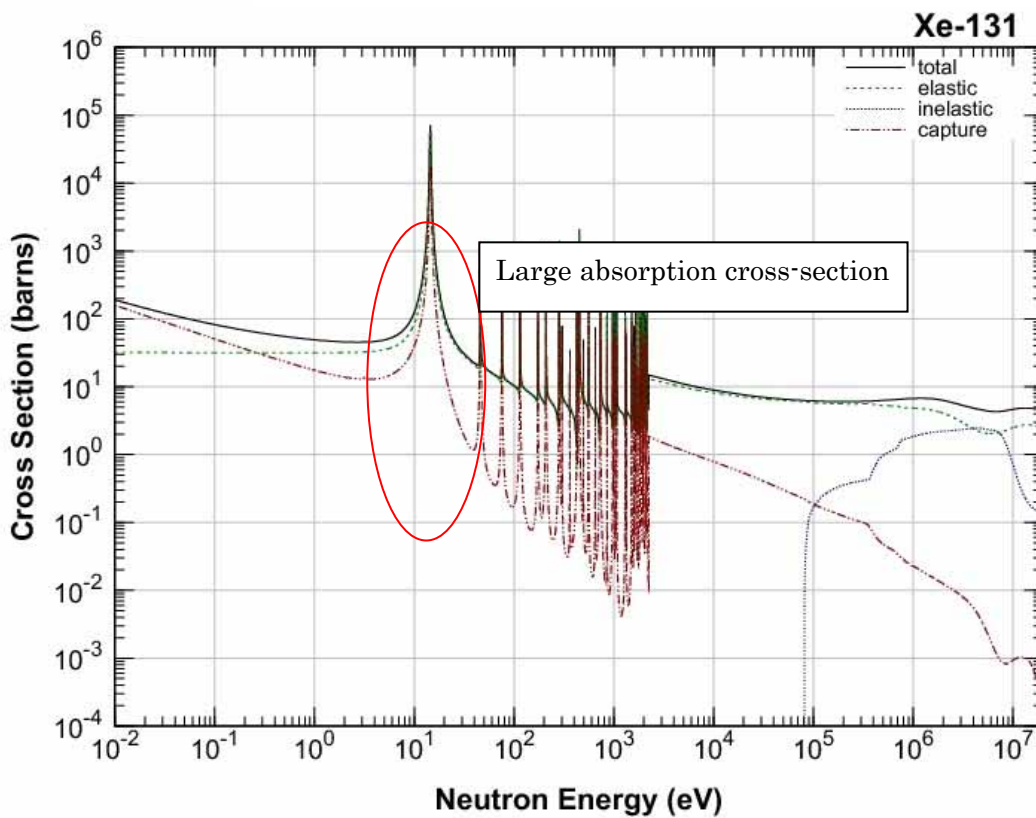

Fig2 Reaction cross-section for Xe131 (JENDL4.0)

Volume evaluation for gas phase in primary containment vessel

It is assumed that there is certain level of water in the primary containment vessel (drywell) in Unit 2 at Fukushima Daiichi Nuclear Power Station. Even though water level inside the drywell is not directly measured, it is estimated around op. 11,000 ~ 12,000 according to hydraulic head pressure inside the primary containment vessel based on the estimation from the differential pressure between residual heat removal system and drywell. The volume inside the primary containment vessel is approximately 3,000m³ if the water level in the primary containment vessel is approximately 1 m below the center line (around op. 11,500) .

< Drywell size >

- Diameter of circular part 2 0 m
- Diameter of cylinder part 1 0 . 9 m
- Height 3 4 . 1 m

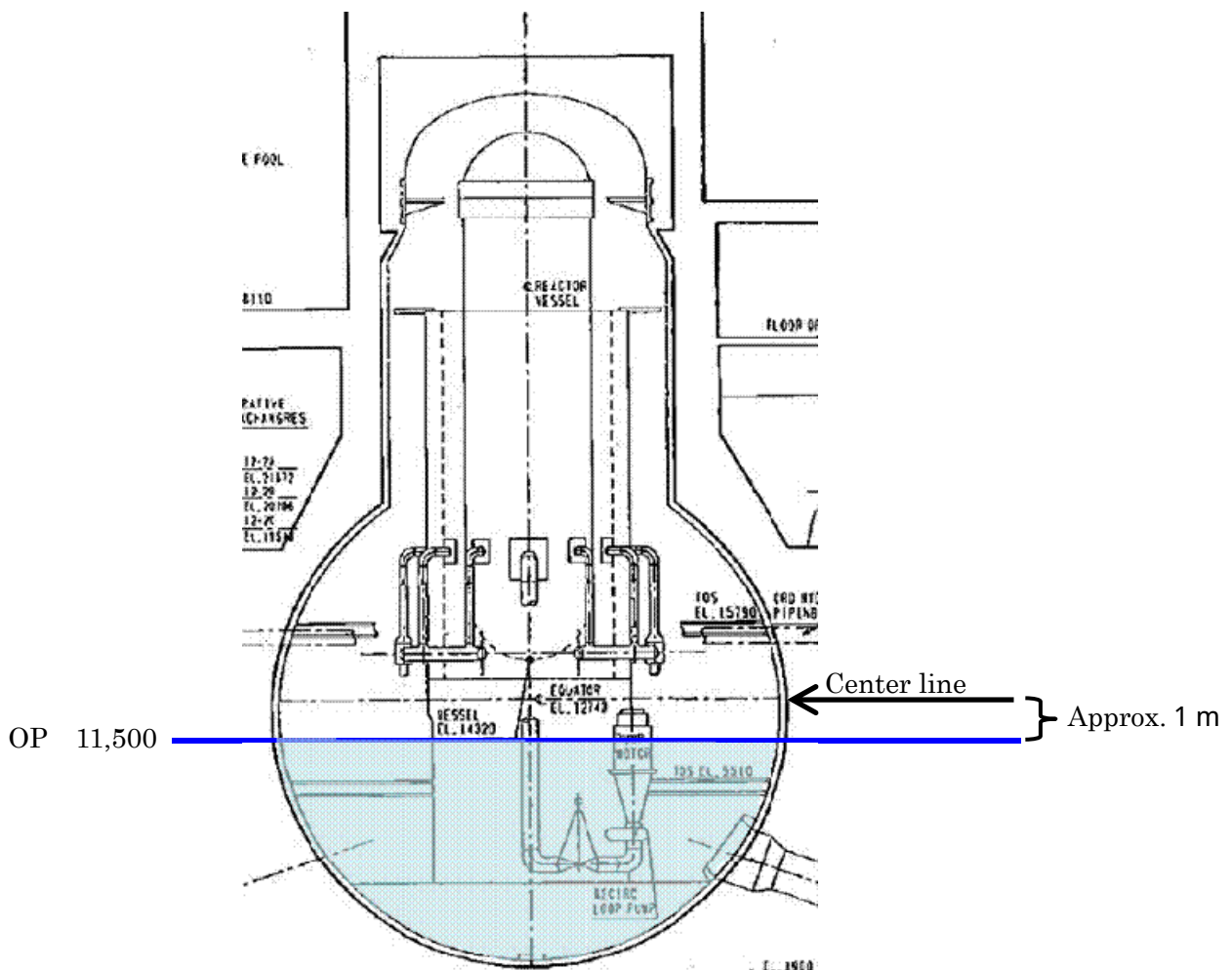

Outline of gas management system for primary containment vessel in Unit 2 and sampling

1 . Emission gas sampling and analysis methods

On October 28, gas management system for primary containment vessel in Unit 2 began operation. As shown in figure 1 below, this system is consisted of fan, radiator, electric heater, filter monitoring instrument etc. Injecting gas inside the primary containment vessel from flammability control system(FCS), and after removing radioactive materials by the filter, part of the gas is vented outside.

In terms of sampling for the gas from the system and nuclide analysis, there are 2 possible methods. One is to analyze by absorbing sample in gas vial container after connecting gas sampling apparatus to the pipe arrangement of intake or outlet of the filter unit. The other method is to analyze dust collected through injecting gas to the filter inside the monitoring instrument installed at outlet of the filter unit.

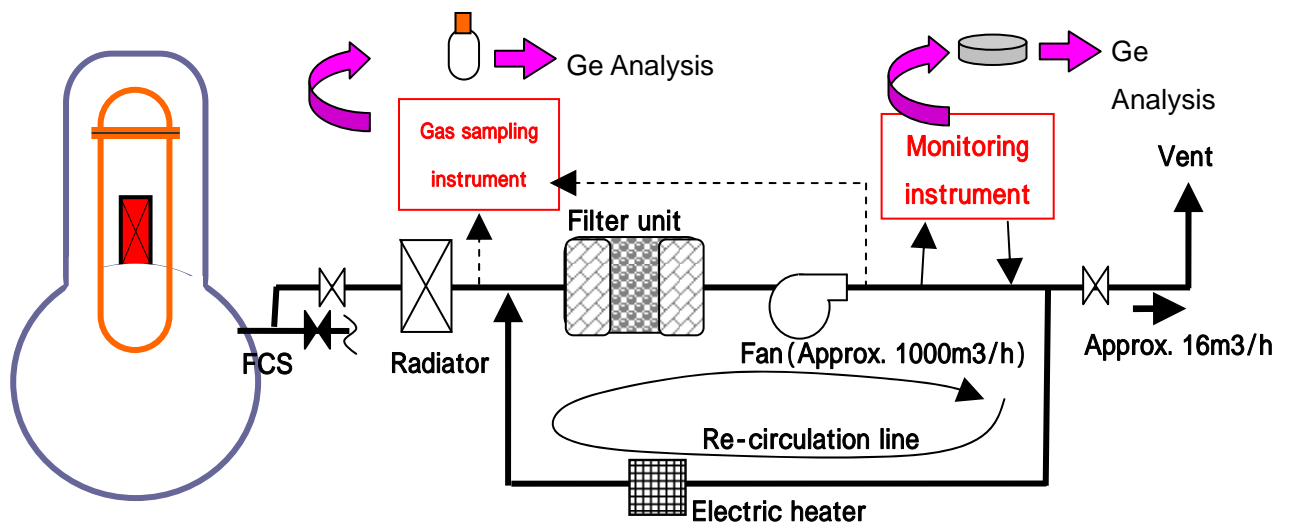
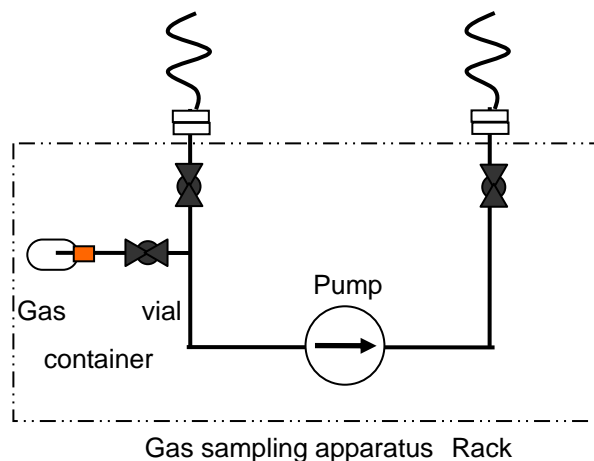

Fig. 1 Overview of gas management system for primary containment vessel in Unit 2

Gas sampling apparatus collect gas to the vacuum suctioned gas vial container after circulating vented gas from piping arrangement of primary containment vessel gas management system



Gas sampling apparatus Rack
14
Fig. 2 Gas sampling apparatus

using absorption pump.

Monitoring instrument absorb vented gas from the outlet of filter unit and measures dust and hydrogen concentration by dust radiation monitor and hydrogen concentration indicator respectively. Also, dust and iodine holder is installed inside the monitoring instrument. The dust holder captures and collects particulate dust contained in absorbed gas through particle filter on wire sheet. The iodine holder captures and collects iodine gas through charcoal cartridge.

Gamma ray analysis is conducted on collected gas and sample from the dust holder (dust collection) using Ge semiconducting detector inside Hotlabo at Unit 5 and 6 in Fukushima Daiichi Nuclear Power Station. The detection limit is depended on whether measured value by gamma ray peak of measured nuclide can be determined from countable number of values from background. Therefore, it is depended on condition of the sample as well as time measured. However, detection limit from the result of measurement were approximately 10^{-1}Bq/cm^3 for Cs-134 in gas vial container sample and approximately 10^{-6}Bq/cm^3 for Cs-134 in dust filter sample. In the case of dust filter, because radiation dose is measured at filter for radioactive materials, it can be measured as radioactivity concentration inside accumulated flow of aeration gas. In this case, the detection limit is lower than gas vial container.

End

Spontaneous fission

Spontaneous fission is phenomenon in which nucleus causes fission spontaneously without any energy or impact from neutron outside. Among naturally-occurring nuclides, spontaneous fission can be observed from uranium. However, half-life period of spontaneous fission for U-238 is 8×10^{15} year and half-life period for α decay is 4×10^9 year, so the ratio of spontaneous fission is extremely small. Inside the reactor, possibility for spontaneous fission is high among uranium of atomic number of 93 or more. According to the calculation result of ORIGEN, as shown in appendix 1-1, contributions of nuclides below are significant.

Chart1 ORIGEN calculation result for the number of neutron generated from spontaneous fission
(Unit : Number of neutron/sec/Initial stage uranium weight1t)

Nuclide	U-238	Pu-238	Pu-240	Pu-242	Cm-242	Cm-244	Cm-246
120 days after cooling	1.20E+04	1.21E+05	1.35E+06	2.25E+05	4.99E+07	2.42E+07	2.97E+04
365 days after cooling	1.20E+04	1.25E+05	1.35E+06	2.25E+05	1.76E+07	2.36E+07	2.97E+04

Condition : ORIGEN

Uranium fuel STEP3Btype Initial stage U-235 Concentration 3.80wt% Specific output 25.52 MW/t

Heat output 2381MWth

Burnup calculation was conducted until average reactor burnup 23.2 GWd/t (estimate) at the shutdown caused by the earthquake, and after that, decay calculation was conducted.

End

Chronological events regarding the injection of boric acid on November 2nd

November 1, 2011

- Conducted dust nuclide analysis for vented gas (measuring fust holder and iodine holder installed in the dust radiation monitor by Ge semiconducting detector) for the purpose of environmental impact assessment.
- Injection of boric acid was considered due to the confirmation of data implying the existence of Xe133 and 135 while analyzing iodine holder.
 - 13:51 Started sampling using iodine holder.
 - 14:20 Finished sampling.
 - 14:54 Started measurement for sampling.
 - 15:37 Finished measurement for sampling.
 - Approx. 20:00 Started consideration for injecting boric acid.
 - Approx. 22:30 Reported injection of boric acid to NISA.

November 2, 2011

- Implemented boric acid injection.
- Remeasuring iodine holder which was collected on November 1 and re-sampling and measurement using new iodine holder.
- Gas sampling and measurement at the filter intake and outlet of gas management system.
 - 0:19 Injection of boric acid was discussed in the unification headquarter.
 - 2:48 Started injecting boric acid.
 - 3:47 Finished injecting boric acid.
 - 10:14 Started remeasurement for sample (collected on Nov.1).
 - 10:47 Finished remeasurement for sample (collected on Nov.1).
 - 11:59 Started sampling from iodine holder.
 - 12:29 Finished sampling from iodine holder.
 - 13:07 Started measurement for sample from iodine holder.
 - 13:40 Finished measurement for sample from iodine holder.
 - 15:25 Sample collected at intake of filter.
 - 15:48 Sample collected at outlet of filter.
 - 16:12 Started measurement for sample from intake of filter.
 - 16:15 Started measurement of sample from outlet of filter.
 - 16:45 Finished measurement for sample from intake of filter.
 - 16:48 Finished measurement of sample from outlet of filter.