

## Outline of the Signed Master Charter Party for the LNG carriers

### 1. Outline

- This master agreement stipulates basic conditions of chartering ships, such as duties and responsibilities of charterers and owners, and conditions of payment of hire rate and other costs.
- This master agreement enables to facilitate negotiation for chartering ships when transportation need for spot cargos arise, thus contributing to efficient and stable supply of LNG.
- The Master Charter Party is signed between three TEPCO's subsidiaries, LNG Marine Transport Limited, Pacific LNG Yuso Limited and Transocean LNG Yuso Limited, and Tokyo LNG Tanker Co., Ltd, a wholly owned Tokyo Gas affiliated company.

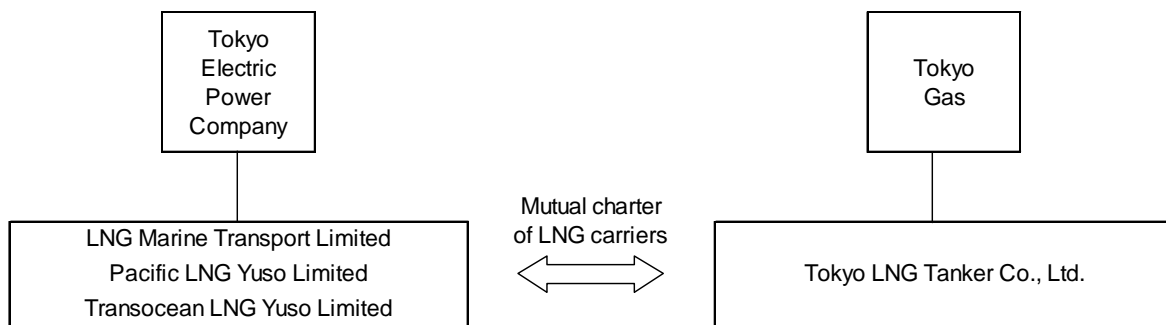

### 2. Date of Agreement: December 21, 2006

### 3. Outline of the subsidiaries

#### **【TEPCO Group】**

- |                 |  |
|-----------------|--|
| 1) Company Name | LNG Marine Transport Limited                         |
| 2) Established  | October 5th, 2004                                    |
| 3) Head Office  | 1-1 Shimbashi 1-chome, Minato-ku, Tokyo, Japan       |
| 4) President    | Makoto Kawaguchi                                     |
| 5) Main Service | Marine transportation of LNG, an agency thereof, etc |
| 6) Capital      | 95 million yen                                       |

- |                 |  |
|-----------------|--|
| 1) Company Name | Pacific LNG Yuso Limited                       |
| 2) Established  | April 20th, 2001                               |
| 3) Head Office  | 1-1 Shimbashi 1-chome, Minato-ku, Tokyo, Japan |
| 4) President    | Masaru Negishi                                 |
| 5) Main Service | Marine transportation of LNG, etc              |
| 6) Capital      | 95 million yen                                 |

- |                 |  |
|-----------------|--|
| 1) Company Name | Transocean LNG Yuso Limited                    |
| 2) Established  | December 10th, 2002                            |
| 3) Head Office  | 1-1 Shimbashi 1-chome, Minato-ku, Tokyo, Japan |
| 4) President    | Masaru Negishi                                 |
| 5) Main Service | Marine transportation of LNG, etc              |
| 6) Capital      | 95 million yen                                 |

#### **【Tokyo Gas Group】**

- |                 |   |
|-----------------|---|
| 1) Company Name | Tokyo LNG Tanker Co., Ltd.  |
| 2) Established  | March 5th, 1991   |
| 3) Head Office  | 5-20 Kaigan 1-chome Minato-ku, Tokyo, Japan   |
| 4) President    | Kazumasa Hidai  |
| 5) Main Service | Owning and Chartering of LNG carriers,<br>Marine transportation of LNG and LPG,<br>Investigation of maritime affairs, etc |
| 6) Capital      | 1.2 billion yen   |