

# Construction Work of the Gas Management System of Unit 3 PCV

Implementation of Installation of Piping of the Gas Management System of the PCV in R/B

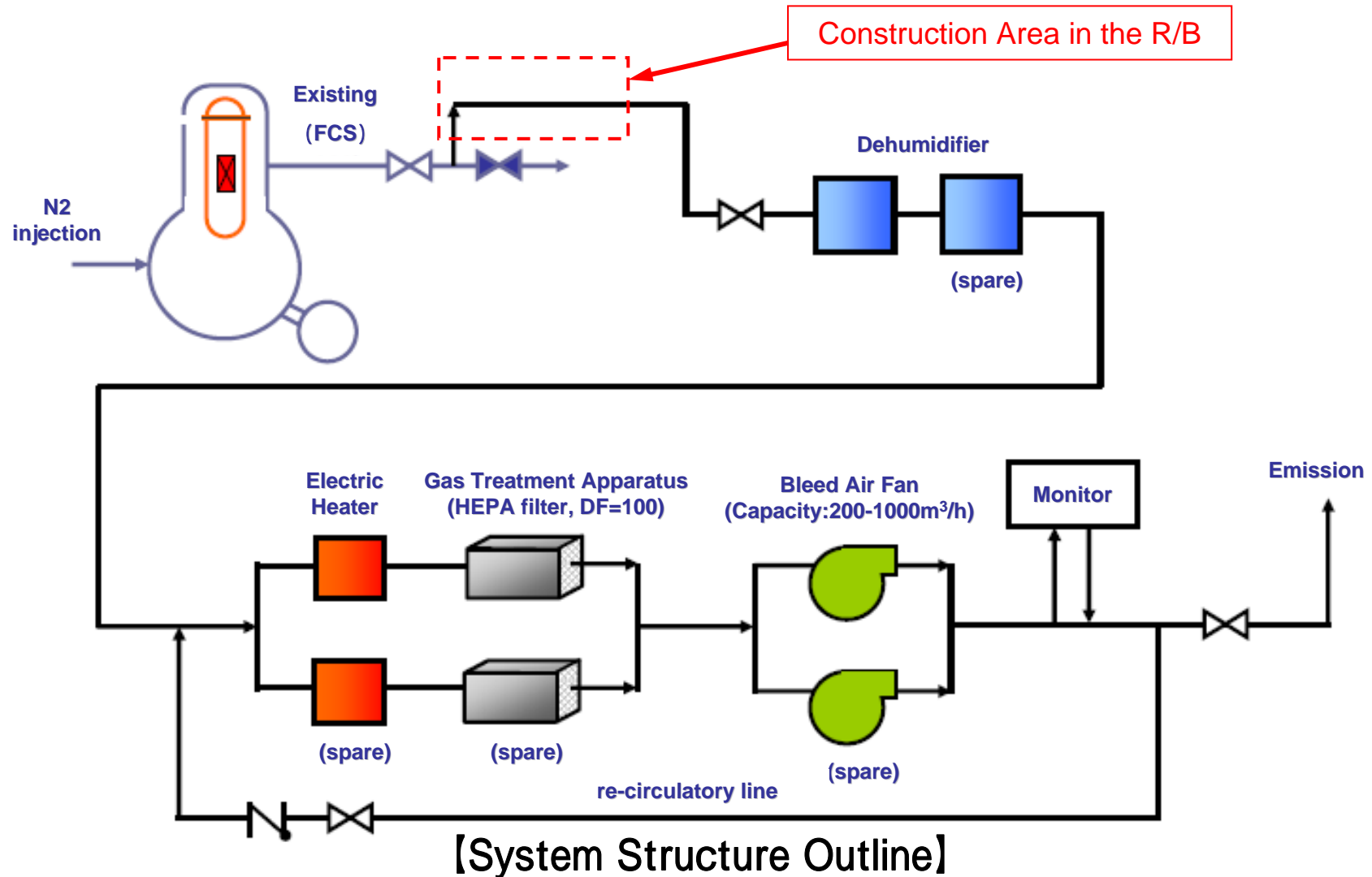

# Concernin Construction Work

Hose and header, etc are moved to the grating base by unmanned unloading cart, which is controlled remotely. By laying hose in the air to avoid to approach to the high-level radiation dose area in front of the hatch of the PCV, the enough length for shield was secured.

1. To Install a winch for winding wire and temporary base to fix the winch
2. To Fix the end of the wire to the permanent grating base. To Connect the temporary line (header, hose etc.) to the test tap of Flammability Control System (FCS)
3. To Winch the wire to hang the hose

