

Water Leakage from the Desalination System (RO2)

< Reference >

January 30, 2013

Tokyo Electric Power Company

Time and Date: At around 4:00 AM on January 30, 2013

Location: In the desalination system (RO2) temporary warehouse

Outline

1. A cooperative company worker found water leakage on the floor of the tent house while performing flushing on the RO membrane (4:00 AM) and reported it to TEPCO (4:09 AM).
2. A TEPCO employee confirmed that the leakage had stopped (5:00 AM). The leaked water remains in the dam.

Estimated leakage amount: Approx. 30L (Approx. 1.5mx20mx1mm)

Radiation dose measurement results (atmosphere)

:0.035[mSv/h], + :0.1[mSv/h]

Radioactivity density analysis results

Cs134: 7.0×10^{-1} Bq/cm³, Cs137: 1.3×10^{-0} Bq/cm³

From the decontamination system

Overview of the Desalination System

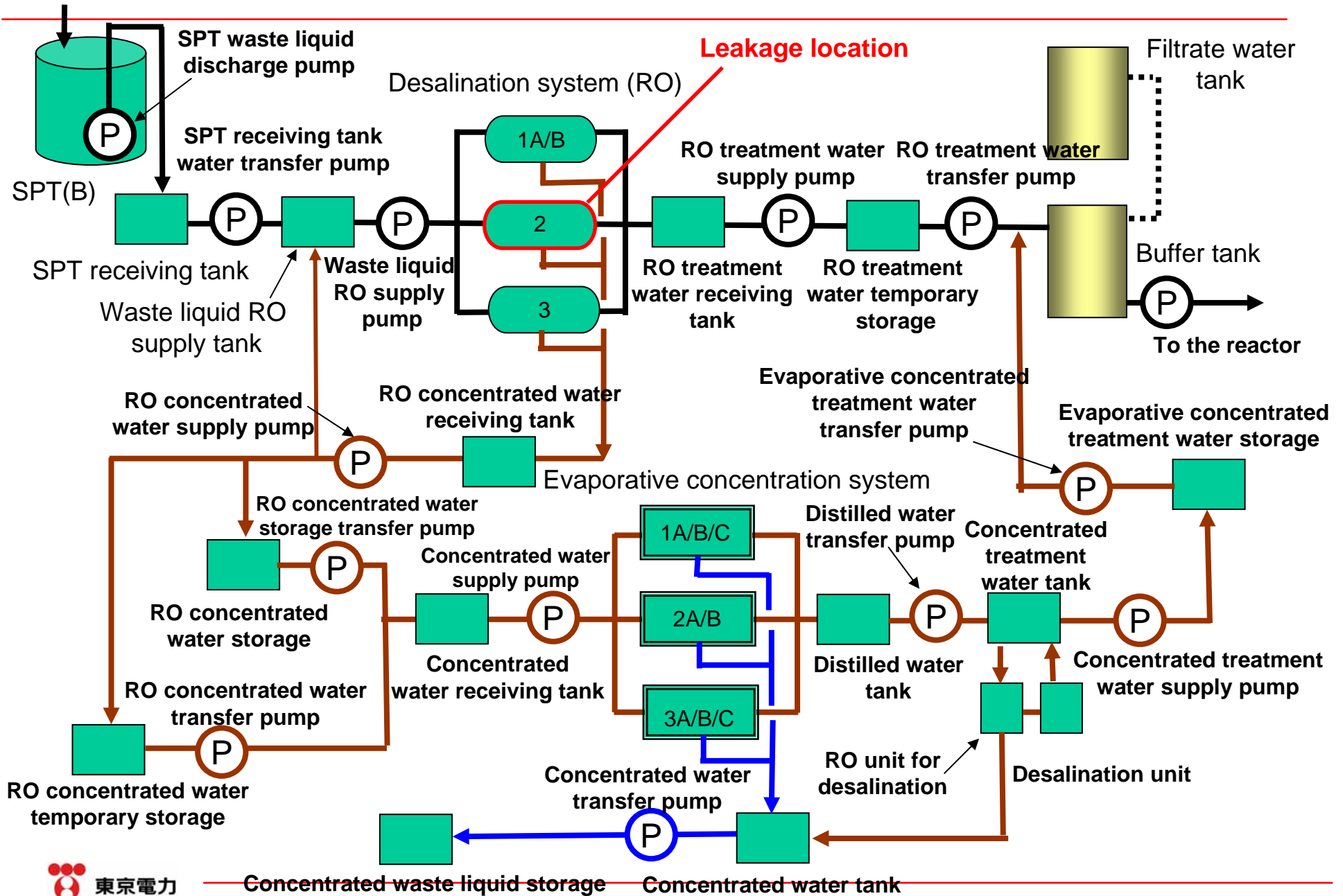

Leakage Location in the Desalination System (RO2)

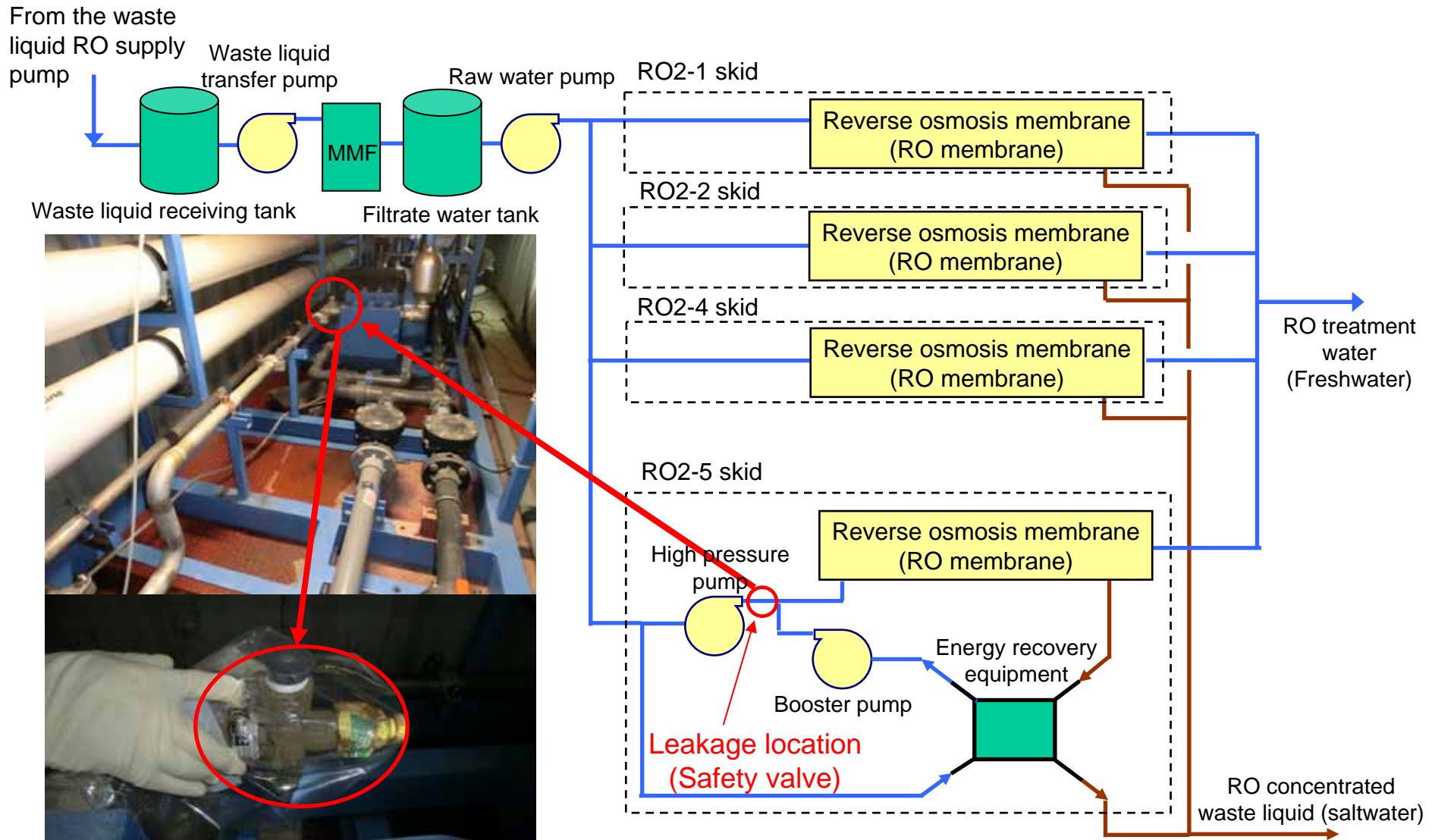

Leakage Location in the Desalination System (RO2)

Desalination system (RO2) temporary warehouse

