

February 29, 2016
Tokyo Electric Power Company

Air Dose Rates inside the Buildings

Sampling Period

Unit 6: from December 1, 2015 to December 31, 2015

Fukushima Daiichi NPS

Unit 6 Reactor Building 2nd Basement Floor

[mSv/h]

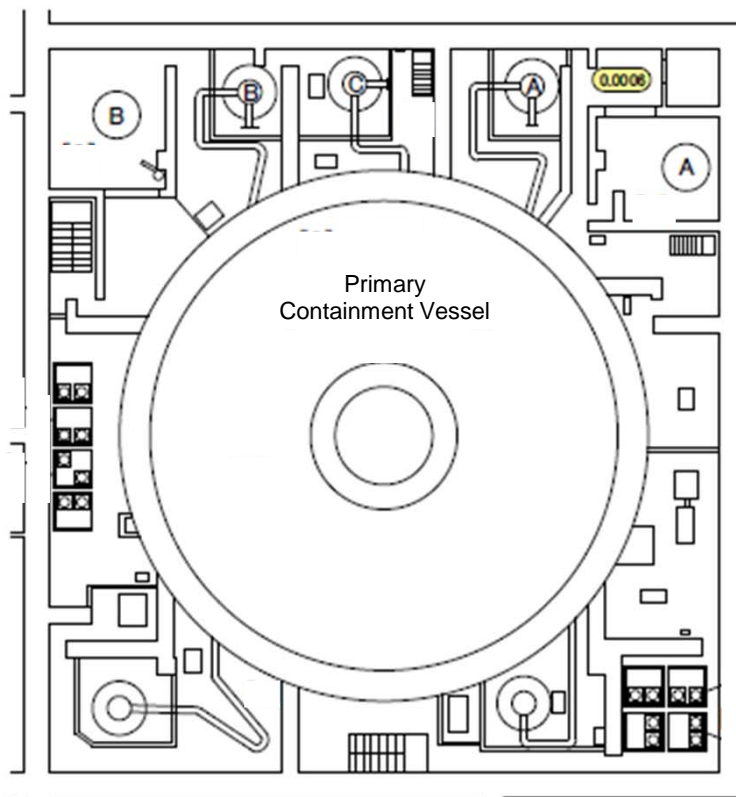
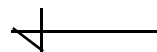

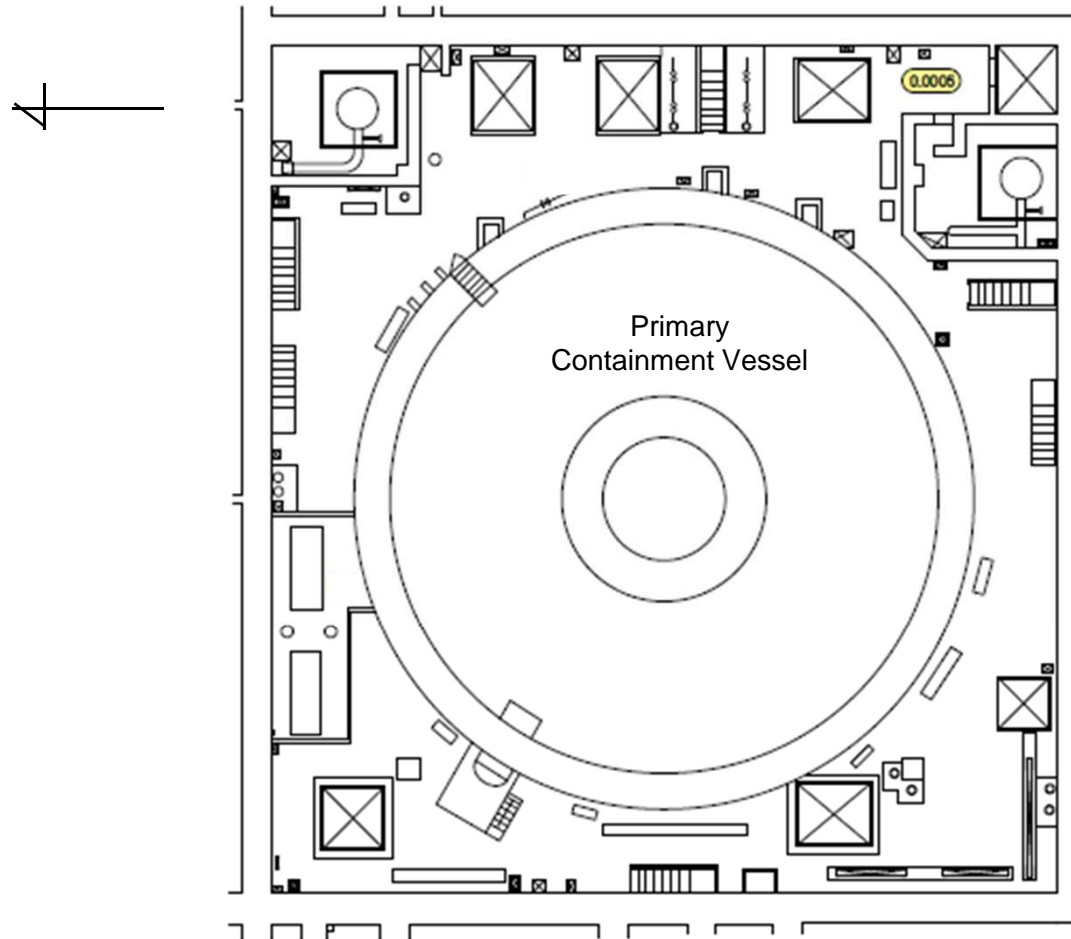

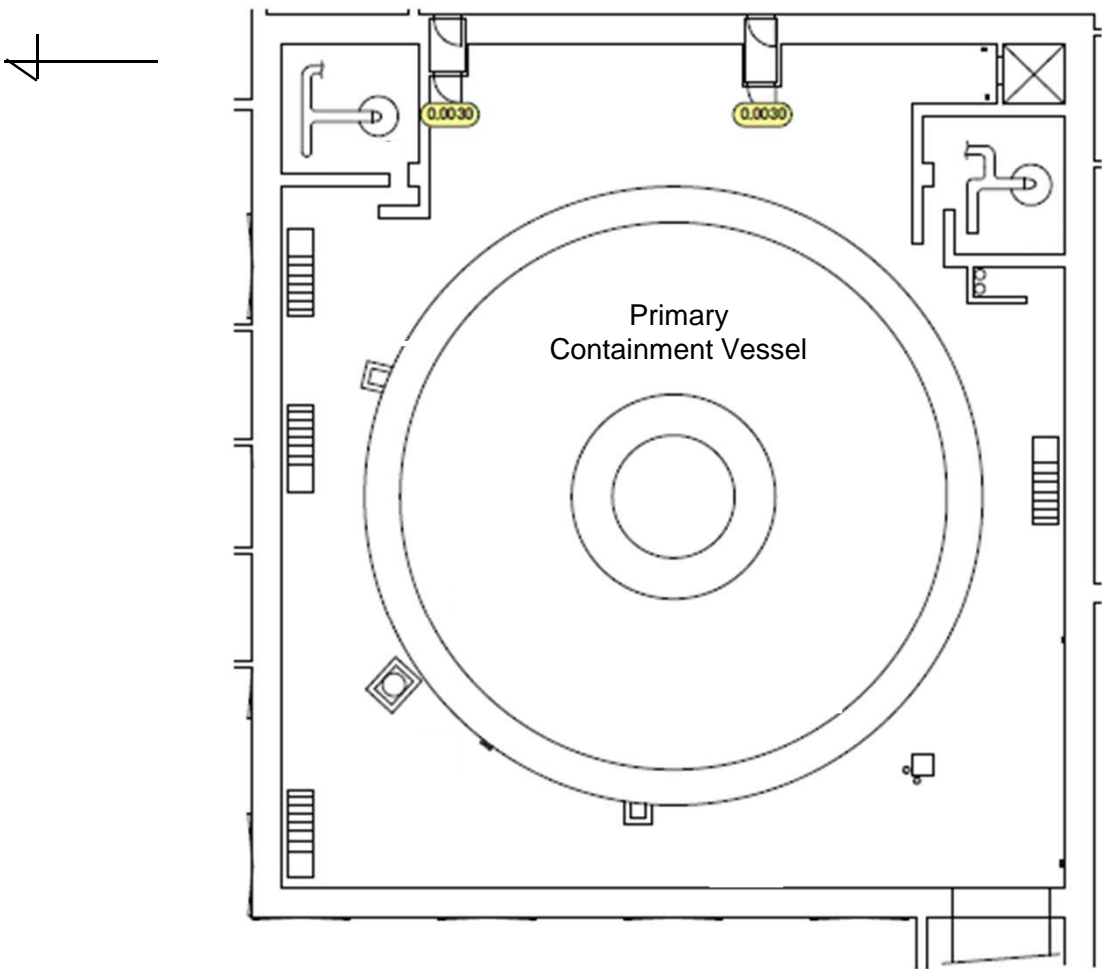

Fukushima Daiichi NPS

Unit 6 Reactor Building 2nd Floor

[mSv/h]

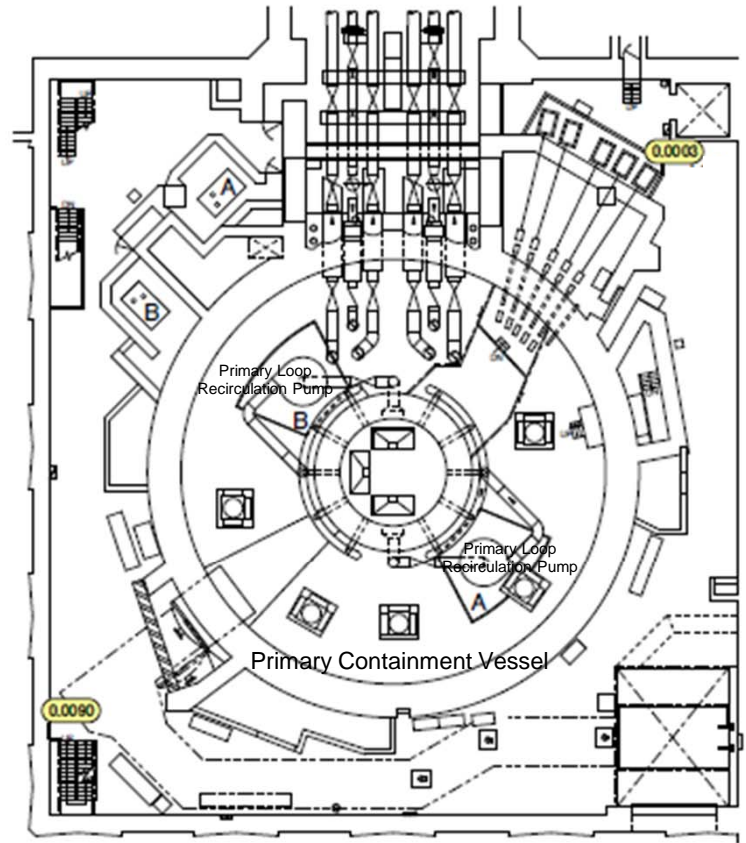
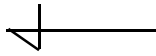

Fukushima Daiichi NPS

Unit 6 Reactor Building 3rd Floor

[mSv/h]

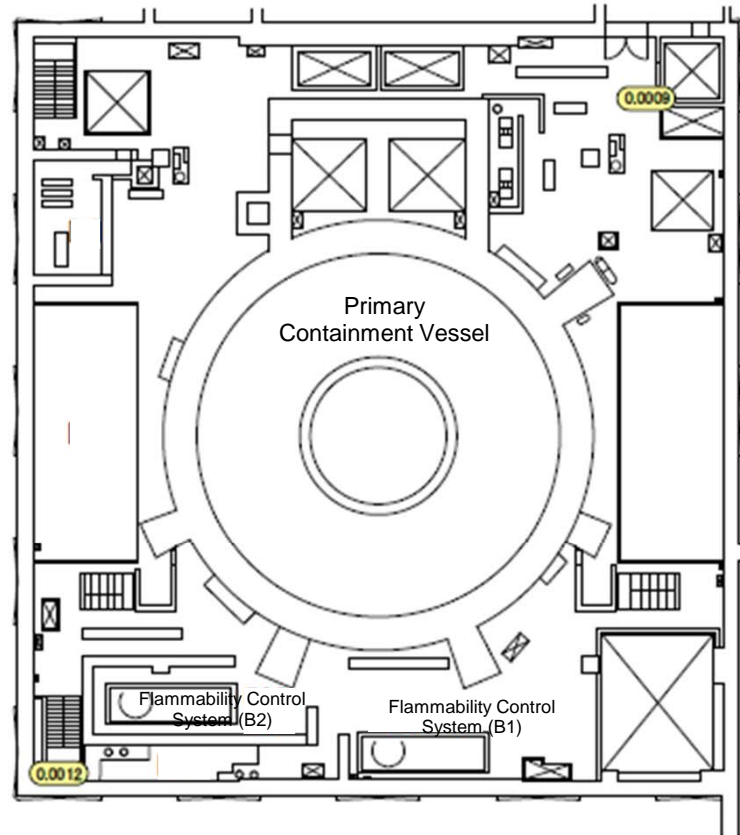
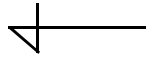

Fukushima Daiichi NPS

Unit 6 Reactor Building 4th Floor

[mSv/h]

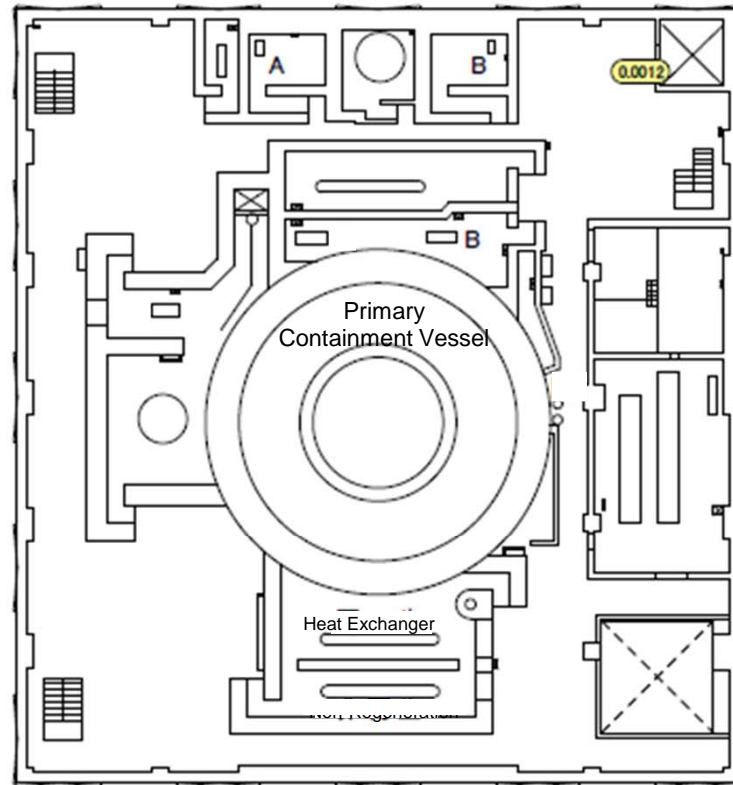
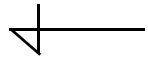

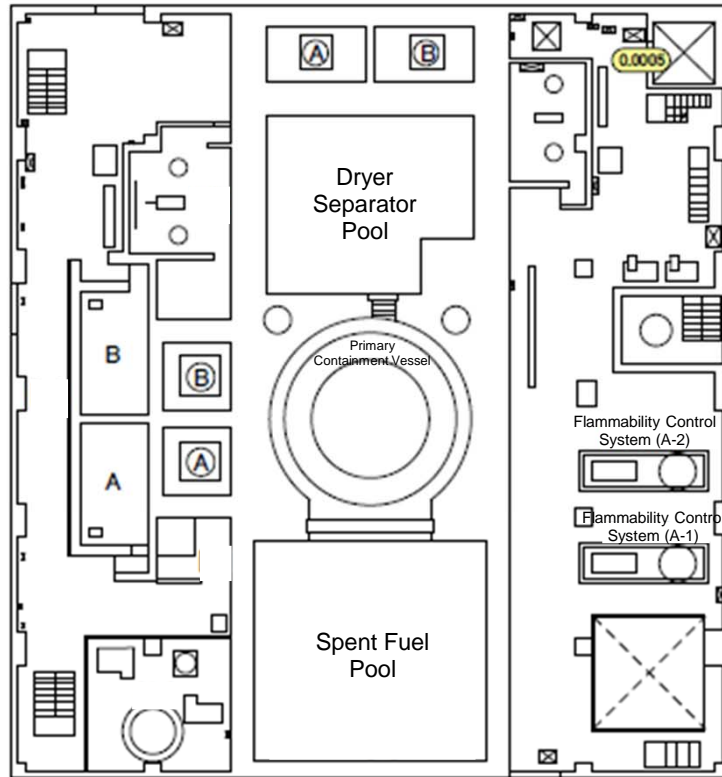
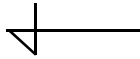

Fukushima Daiichi NPS	Unit 6 Reactor Building 6th Floor	[mSv/h]
-----------------------	-----------------------------------	---------

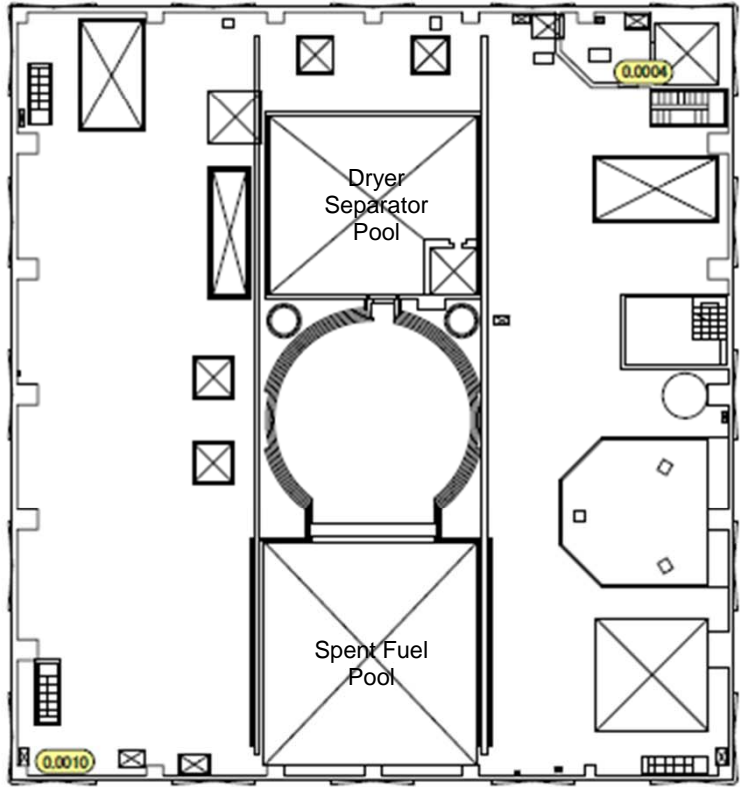
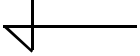

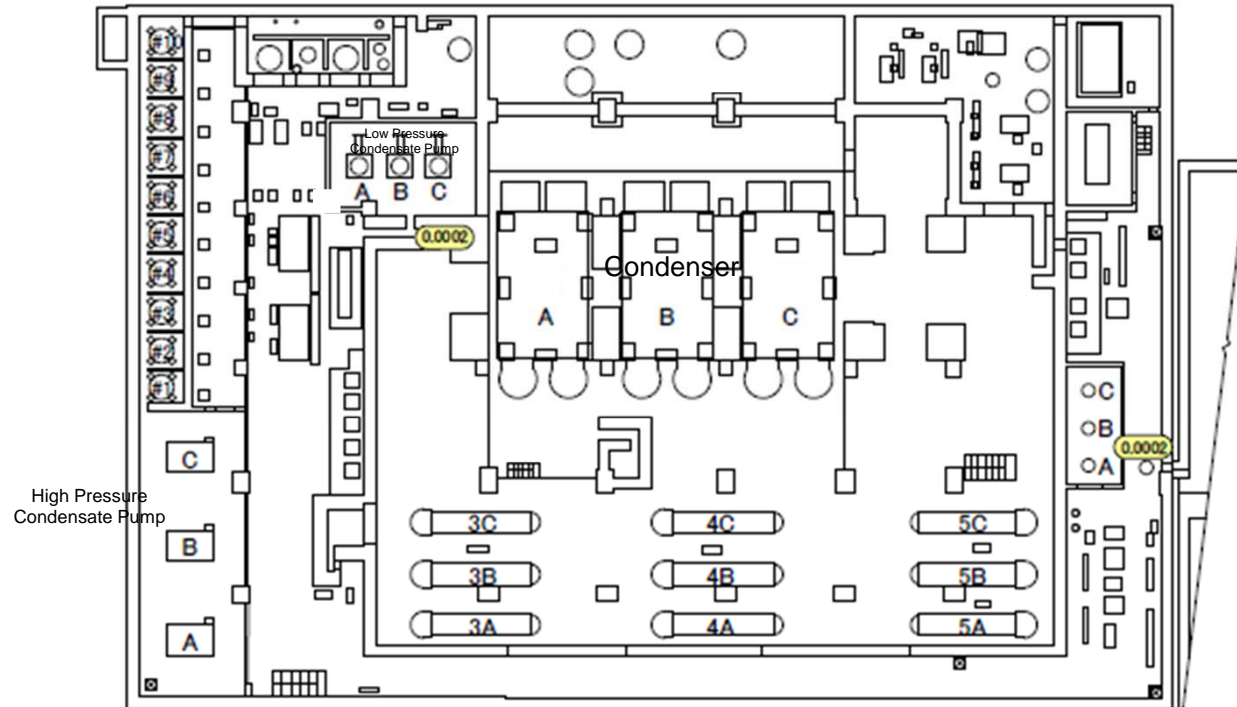
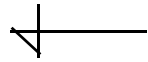

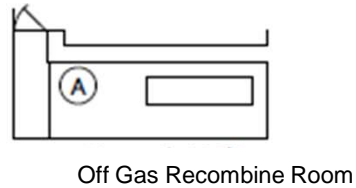
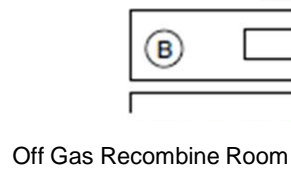
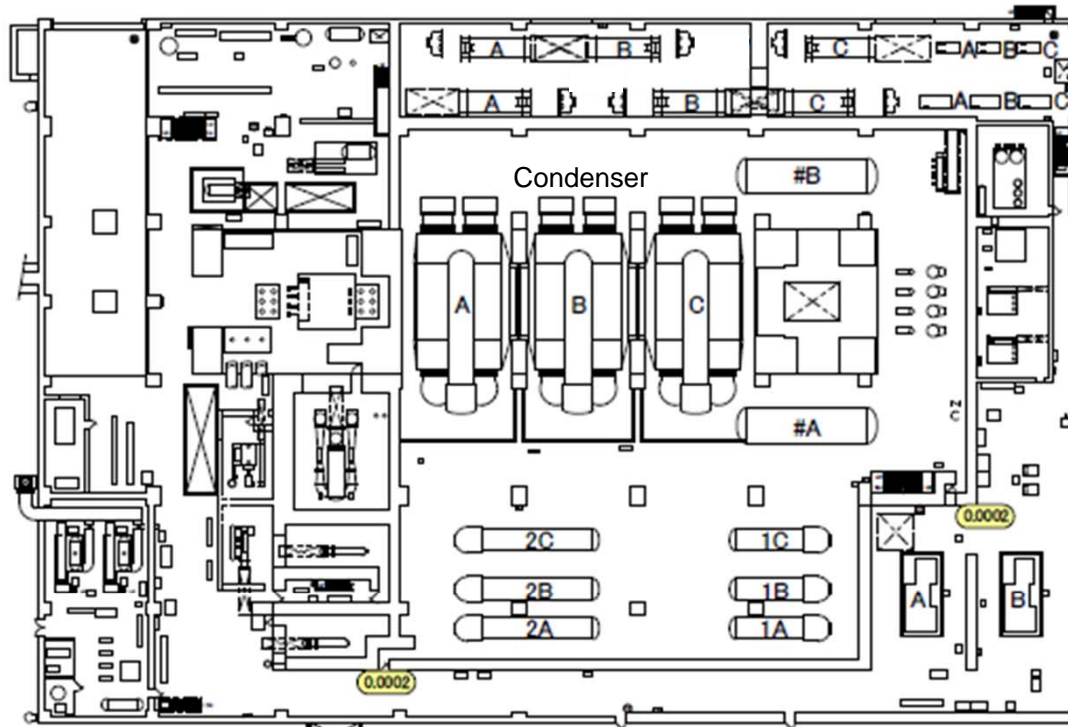
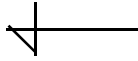

Fukushima Daiichi NPS	Unit 6 Turbine Building 2nd Floor	[mSv/h]
-----------------------	-----------------------------------	---------

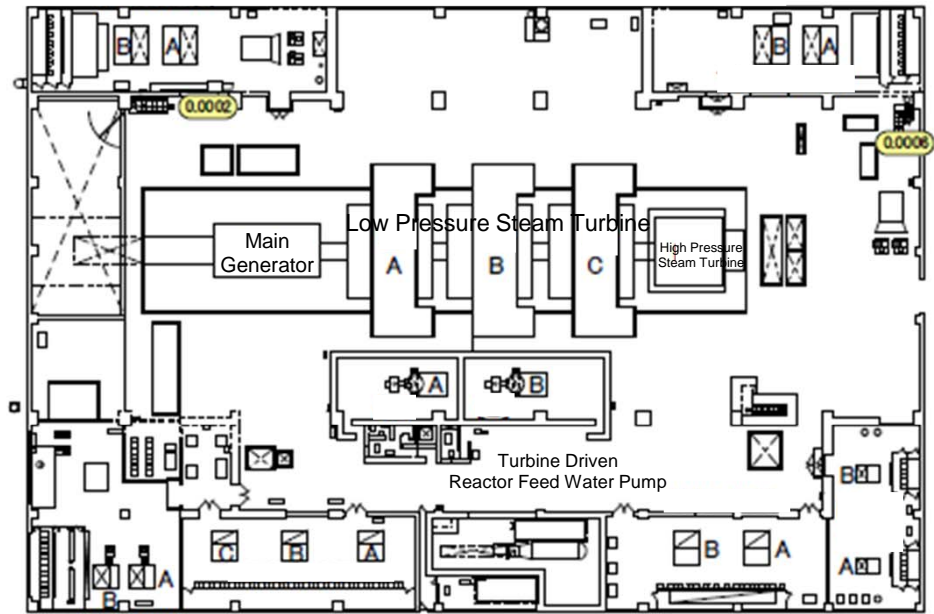
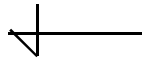

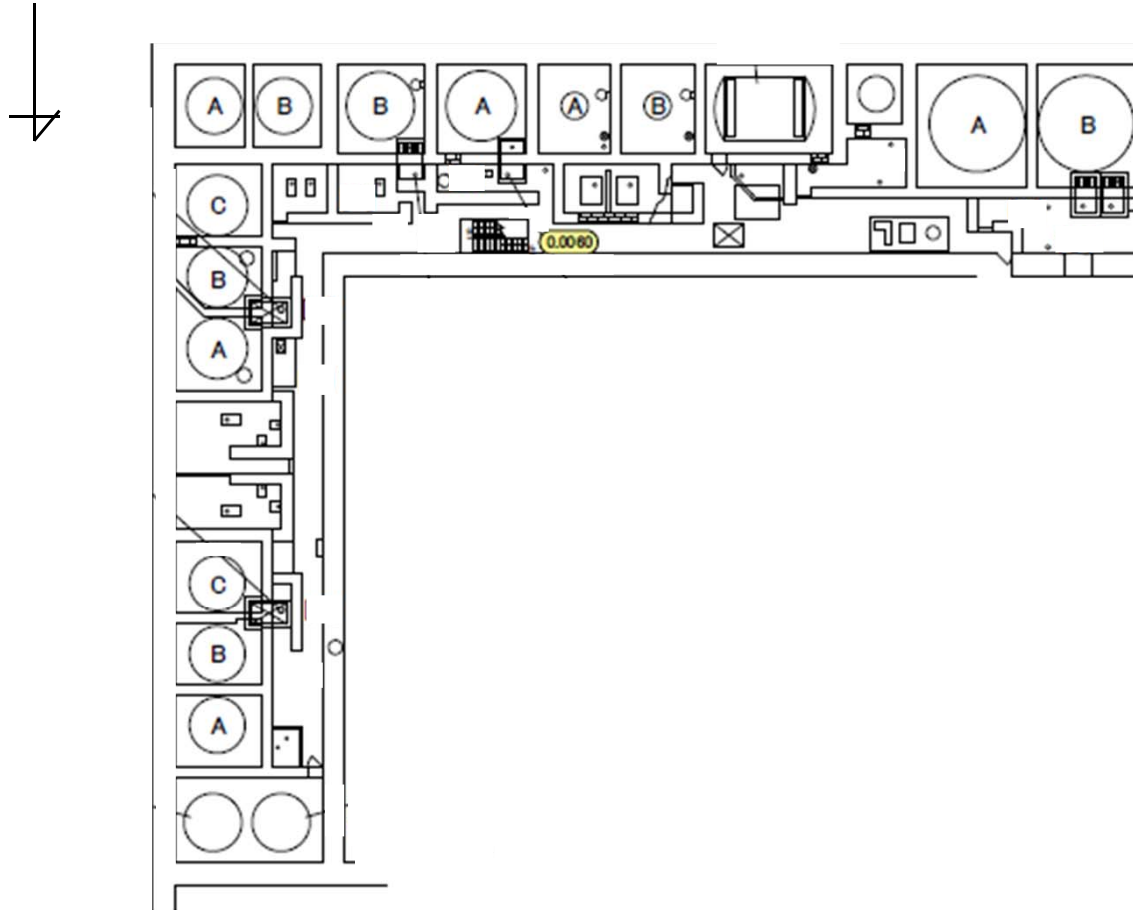

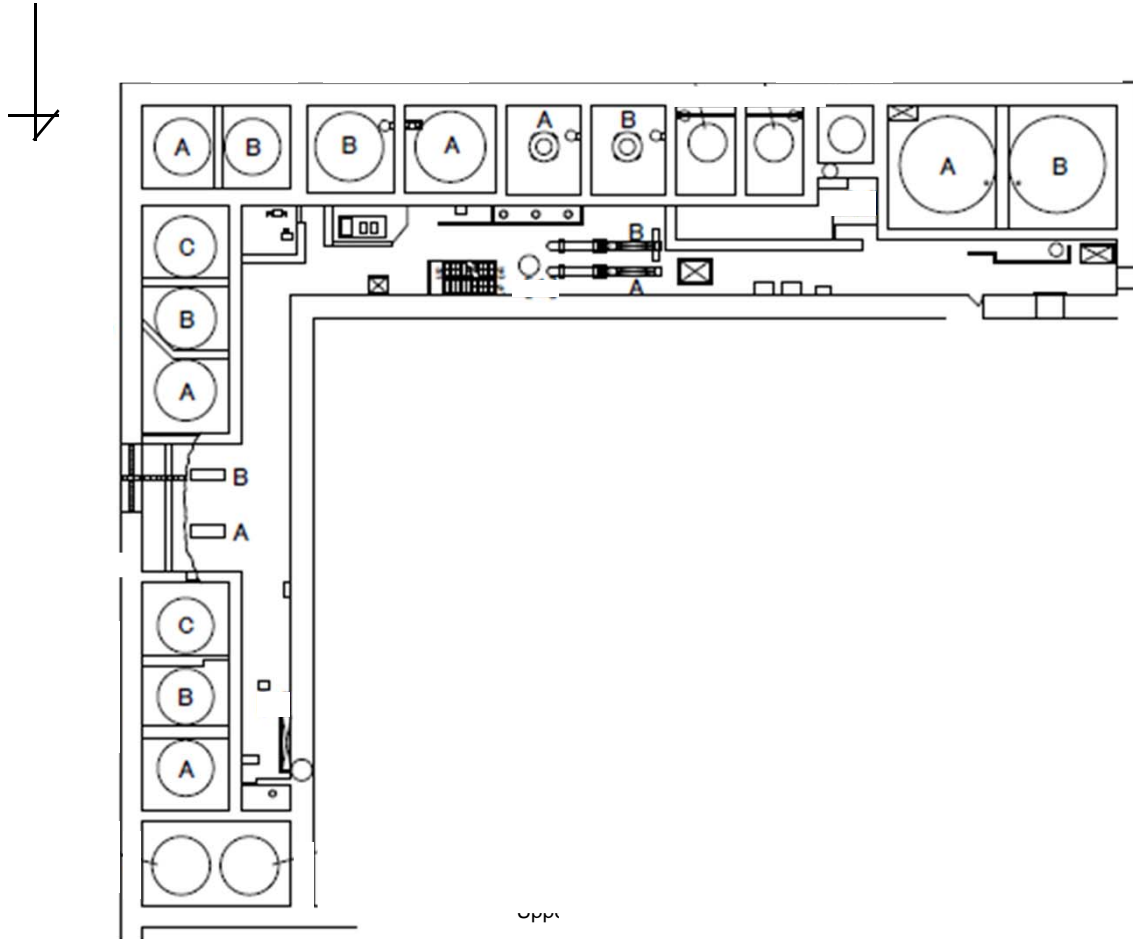

Fukushima Daiichi NPS

Unit 6 Radioactive Waste Treatment Facility 1st Floor

[mSv/h]

