

Installation of New ALPS Treated Water Dilution/Discharge Facilities and the Related Facility

27th January, 2022



Tokyo Electric Power Company Holdings, Inc.

Responses to major issues^(*) concerning the content of the application for the Discharge Facility of ALPS Treated Water into the Sea

*Document 1-2 for (The 3rd) Review Meeting on the Implementation Plan Regarding the Handling of ALPS Treated Water

(2-2 Major items to be confirmed regarding activities in line with government policy)

(3) Radiological Impact Assessment on Surrounding Environment due to the discharge into the Sea

(2-1 Major issues to be reviewed based on the Nuclear Reactor Regulation Act)

(1) Discharge Facility of ALPS Treated Water into the Sea

(5) Structure and strength of equipment, protection against natural phenomena such as earthquakes and tsunamis, misoperation prevention, reliability, etc.

Responses to major issues^(*) concerning the content of the application for the Discharge Facility of ALPS Treated Water into the Sea

*Document 1-2 for (The 3rd) Review Meeting on the Implementation Plan Regarding the Handling of ALPS Treated Water

(2-2 Major items to be confirmed regarding activities in line with government policy)

(3) Radiation Effects Assessment on Surrounding Environment due to the discharge into the Sea

- Explanations must be provided regarding how it is considered that the evaluation method described in the radiation effects assessment Report conforms to the **safety standards and guidelines set by the IAEA**, and that the evaluated results are sufficiently small when compared with the range of annual radiation dose that humans are exposed to in the region and environment where they live.
- Regarding **source terms that have been set based on the upper limits for discharge management**, the rationale and validity of the setting must be explained, including the procedures for selecting radionuclides subject to management. In addition, an explanation must be given regarding how the annual discharge of tritium was evaluated while taking into account annual changes in the operating rate of the facilities for the discharge into the sea.
- The validity of **the dispersion model** for this radiation effects assessment must be explained by showing how this model simulates the dispersion in the sea around the Fukushima Daiichi NPS. Furthermore, the adequacy of the scope of modeling must also be explained, for example, by showing concentrations of radioactive materials at the boundaries of the modeling scope.
- The rationale for selecting **the transfer models** must be explained, such as the scope to be covered and why some transfer models were exempt from the assessment.
- The rationale for selecting **exposure pathways** must be explained, such as the scope to be covered and why some exposure pathways were exempt from the assessment.
- **When values that are not mentioned in any documents, such as IAEA guidelines, are adopted**, the rationale for and validity of those values must be explained while taking into account the uncertainties in the assessment.
- Explanations must be given regarding why the impacts of potential exposures were assessed without using the flow chart in Figure 3 of GSG-10. The rationale for the setting of the scenario used for **the potential exposure assessment** must also be explained.

1. Overview of the Radiological Impact Assessment

- In line with the Basic Policy of the national government, TEPCO announced, on 16th April 2021, TEPCO Holdings' Action in Response to the Government's Policy on the Handling of ALPS Treated Water from the Fukushima Daiichi NPS, showing the following course of action.
 - In discharging ALPS treated water into the sea, TEPCO will ensure that the discharged water is safe by conforming to safety standards based on laws, and relevant international laws and practices. Thus we will secure the safety of the public, the surrounding environment, and of agricultural, forestry and fishery products.
 - ✓ In order to ensure the safety of the public and the surrounding environment, TEPCO will make sure that the concentrations of tritium and other radioactive materials in the water to be discharged satisfy the national regulatory limits, laws, and ordinances conforming to international standards (IAEA Safety Standards, ICRP Recommendations, etc.).
 - ✓ Before moving on to the procedures for obtaining necessary approval by the Nuclear Regulatory Authority, TEPCO will evaluate the safety by assessing the radiological impact on humans and the environment that may be caused when the discharge is performed after securing the above conditions. The results will be published and reviewed by IAEA experts.
- This radiation effects assessment was conducted based on the above concept.

2-2(3) Radiological Impact Assessment on surrounding environment due to discharge into the sea

1.2 Assessment methods (consultation with IAEA Safety Standards, Guidelines, etc.)

- This assessment is based on the IAEA Safety Standards GSG-9 “Regulatory Control of Radioactive Discharges to the Environment” (hereinafter referred to as GSG-9) and predicts and evaluates, from the viewpoint of the operator, the radiological impact associated with the discharge of ALPS Treated Water into the sea.
- The detailed assessment procedures are based on IAEA GSG-10 “Prospective Radiological Environmental Impact Assessment for Facilities and Activities” (hereinafter referred to as GSG-10). In addition, this assessment evaluated potential exposures, which are exempt in GSG-9, and Assessment for Environmental Protection, which is not subject to regulations in Japan.
- IAEA and ICRP documents consulted
 - Effective dose coefficients for internal exposure: ICRP Pub.72, “Age-dependent Doses to Members of the Public from Intake of Radionuclides; Part 5 Compilation of Ingestion and Inhalation Doses Coefficients”
 - Concentration coefficients for marine organisms and sediment distribution coefficient: IAEA TRS-422 “Sediment Distribution Coefficients and Concentration Factors for Biota in the Marine Environment”
 - Concentration ratios for marine organisms: ICRP Pub.114 “Environmental Protection: Transfer Parameters for Reference Animals and Plants”
 - Dose conversion coefficients for marine organisms: ICRP Pub.136 “Dose Coefficients for Non-human Biota Environmentally Exposed to Radiation” and BiotaDC Program
 - As assessment criteria, the annual dose limit of 1 mSv/year for the general public set by the ICRP was adopted when assessing human exposures; and in the Assessment for Environmental Protection, the Derived Consideration Reference Levels (DCRLs) described in ICRP Pub.124 “Protection of the Environment under Different Exposure Situations” were used.

1.3 Structure of the Radiological Impact Assessment Report

The main body reports the assessment of human exposures, while the assessment results for environmental protection and potential exposure are summarized as references.

- Main body Assessment of human exposures
 - Objective of the assessment
 - Approach to the assessment
 - Quality and discharge method of ALPS treated water
 - Assessment method
 - Exposure assessment
 - Summary

- Reference A Assessment of potential exposures
- Reference B Assessment for Environmental Protection
- Reference C Rationale for the selection of radionuclides subject to removal by ALPS
- Reference D Quality of ALPS treated water, etc.
- Reference E Setting of target discharge management values
- Reference F Change in dispersion area by discharge location
- Reference G Contribution of undetected nuclides in the source terms based on measured values
- Reference H Breakdown of exposure assessment results by nuclide
- Reference I Uncertainties in this assessment

- Glossary

2. Assessment of Human Exposures

2.1 Approach to the assessment

- Human exposures during normal operation were assessed in accordance with the following procedure, which is shown by IAEA GSG-10.

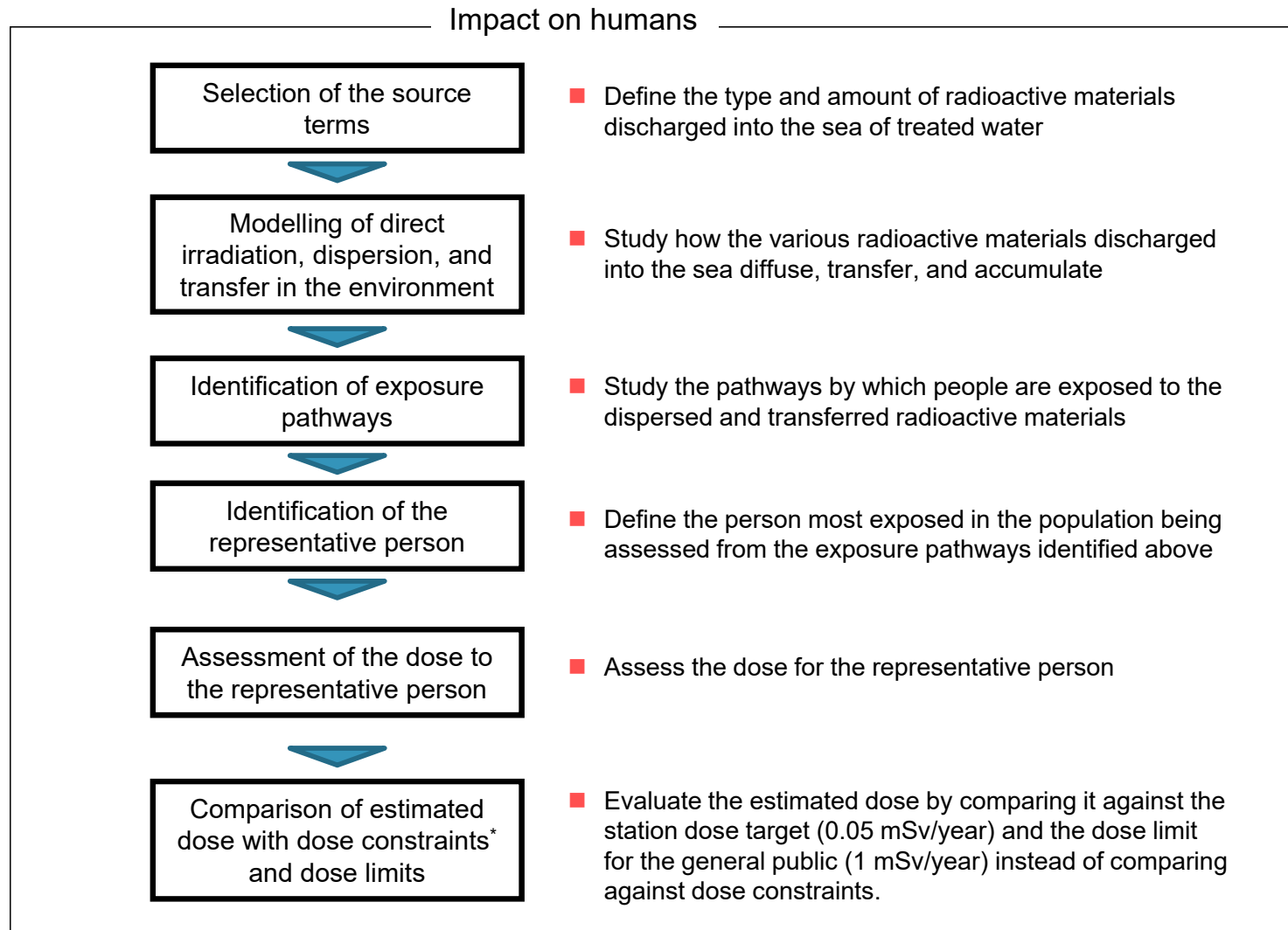

* Dose constraint: A value lower than the dose limit, stipulated by the person responsible for radiation work or the radiation facility to optimize safety in physical protection. Because there is no legal dose constraint in Japan, values in this case were compared to the station target dose.

2.2 Discharge method assumed for the assessment

- The discharge method for the assessment was assumed as follows based on the “TEPCO Holdings’ Action in Response to the Government’s Policy ”, which was discharged by TEPCO in line with the basic policy established by the government.
 - The ALPS Treated Water is purified before discharge until the sum of the ratios of 62 radionuclides other than tritium and carbon 14 becomes less than 1. Before discharge, all of the 64 radionuclides are measured and evaluated (including measurement and assessment by a third party) to ensure that the ALPS Treated Water has been purified as described above.
 - The annual tritium discharge is set to less than 22 trillion Bq, the target discharge management value set for Fukushima Daiichi NPS before the accident.
 - The diluted ALPS Treated Water is discharged from a point on the sea bottom about 1 km offshore of the power plant to avoid taking in the discharged water again as seawater for dilution as much as possible.
- Before discharge, ALPS Treated Water is diluted with seawater 100 times or more to ensure that the tritium concentration at the discharge outlet is less than 1,500 Bq/L. As a result, the sum of the ratios of the 62 radionuclides other than tritium and carbon 14 will also be diluted to less than 1/100.
- In the assessment, ALPS Treated Water is assumed to be discharged under the same conditions throughout the year. In the actual operation, however, the amount of discharge will vary throughout the year due to reasons such as the suspension of facilities. Furthermore, the amount of tritium discharged along with ALPS Treated Water will change year by year. However, this does not affect the conservativeness of the assessment because of the following reasons: there is little effect on the exposure due to tritium; conservative values were set in the assessment as the discharge amounts of radionuclides other than tritium; and in the assessment, concentration in fish and shellfish and adhesion to the seabed are assumed to achieve an equilibrium state with the concentration in seawater over a long period of discharge.

2.3 Source term setting (1)

- The nuclides subject to assessment are 64 nuclides: the 62 nuclides, which are to be removed from ALPS treated water, C-14, and H3. Since it is impossible to precisely identify the nuclide composition of the ALPS Treated Water to be discharged, two types of source terms were set: (1) source term based on measured values, and (2) source term based on hypothetical ALPS Treated Water that is simulated in such a way that maximizes exposures.

(1) Source terms based on the measured value of the 64 radionuclides

The assessment assumes that the ALPS Treated Water from the three particular tank groups from which the actual measurements for the 64 nuclides have been gathered is diluted by seawater and then continuously discharged during the discharge period.

Furthermore, radionuclides that have not been detected before are assumed to be included at their detection limit.

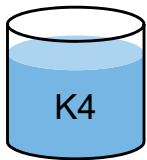

- (1)-1 K4 tank group
Tritium concentration: approx. 190,000 Bq/L
The sum of the ratios of radionuclides other than tritium: 0.29

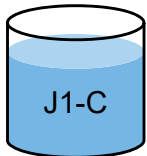

- (1)-2 J1-C tank group
Tritium concentration: approx. 820,000 Bq/L
The sum of the ratios of radionuclides other than tritium: 0.35

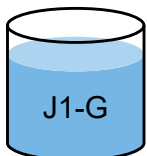

- (1)-3 J1-G tank group
Tritium concentration: approx. 270,000 Bq/L
The sum of the ratios of radionuclides other than tritium: 0.22

All scenarios assume that the amount of tritium in discharged treated water is less than 22 trillion Bq per year.

2.4 Setting of the source terms (2)

(2) Source terms based on hypothetical ALPS treated water

An extremely conservative scenario assumes that the hypothetical ALPS Treated Water with only nuclides that comparatively have a more significant effect on exposure dose, which does not actually exist, is diluted with seawater and then continuously discharged throughout the discharge period.

- 8 important radionuclides* in assessing human effects are selected, and **target discharge management values** are set for them (see next slide).
- In order to conservatively maximize the estimated dose, the radionuclide composition in the ALPS Treated Water was assumed as follows: the 8 nuclides are contained at their maximum limits (target discharge management values) (the sum of the ratios of the 8 nuclides is 0.32), and then the radioactive material that has the most significant impact following the 8 nuclides (Zinc 65) is assumed to be contained until the sum of the ratios of radionuclides reaches 1 (the ratio of Zn-65 to the ratio to regulatory concentration limit : 0.68).
- Since the amount of tritium discharged is less than 22 trillion Bq/year, and the lower the concentration of tritium is the more other radioactive materials are discharged, the tritium concentration of the treated water to be used in the assessment is set at 100,000 Bq/L, below the lowest tritium concentration observed (approx. 150,000 Bq/L), to conservatively maximize the calculated exposure dose.



(2) The hypothetical ALPS treated water

Tritium concentration : The sum of the ratios approx. 100,000 Bq/L
of radionuclides other than tritium: 1.00

* Radionuclides that tend to be accumulated in fish and shellfish, and releasing them at the same concentration ratio as the legally required limit leads to a relatively larger calculation result of exposure dose (See next slide).

2-2(3) Radiological Impact Assessment on surrounding Environment due to Discharge into the Sea

2.5 Selection of radionuclides important to assessment and target discharge management values

- The discharge of ALPS Treated Water is managed based on the sum of the ratios to regulatory concentration limits. However, even when discharged at the same concentration ratio, each radionuclide behaves differently in the environment. Therefore, radionuclides that have relatively large impact on exposure doses (= exceeds 0.001 mSv/year) when discharged at the same concentration ratio as the regulatory concentration limits were selected, and target discharge management values (upper limits for discharge management) were set for them to reduce exposures.
- As a result, setting a hypothetical ALPS Treated Water enable us to conduct a radiation impact assessment with the most conservative source term. The assumed Hypothetical ALPS Treated Water was : the water contains top 8 radionuclides, which have larger impact on exposure doses when discharged at the same ratio to the regulatory concentration limits, and followed zinc 65, which has the next largest impact on exposure doses, to make up the remaining portion of the sum of the ratios of 8 radionuclides mentioned above until the sum becomes 1.

Table: Results of internal exposure assessment when each nuclide is discharged at the regulatory concentration limit (Adult)

(8 nuclides that exceed 0.001mSv/year were selected to be managed)

No.	Target nuclide	Regulatory concentration limit [Bq/L]	Internal exposure dose due to ingestion of seafood (mSv/year)	Notes
1	Sn-126	2.0E+02	2.6E-02	Subject to management
2	Sn-123	4.0E+02	2.3E-02	Subject to management
3	Sn-119m	2.0E+03	1.9E-02	Subject to management
4	Fe-59	4.0E+02	5.6E-03	Subject to management
5	Cd-115m	3.0E+02	1.4E-03	Subject to management
6	C-14	2.0E+03	1.3E-03	Subject to management
7	Cd-113m	4.0E+01	1.3E-03	Subject to management
8	Ag-110m	3.0E+02	1.0E-03	Subject to management
9	Zn-65	2.0E+02	8.4E-04	
10	Mn-54	1.0E+03	5.2E-04	
11	Co-58	1.0E+03	2.5E-04	
12	Co-60	2.0E+02	2.3E-04	
13	Co-60	2.0E+02	2.1E-04	

***[Setting of target discharge management values]**

- For nuclides that have been detected before: double the maximum detected value
- For nuclides that have not been detected before: 1.2 times the detection limit
- The sum of the ratios of these 8 radionuclides is 0.32

-> ALPS Treated Water that contains nuclides at concentrations that exceed the target discharge management values will be repurified until the concentrations satisfy the discharge limits, even if the sum of the ratios of the 63 radionuclides is less than 1.

2.6 Flow for setting the target discharge management value

■ Step 1
Calculate the magnitude of exposure at a certain ratio to regulatory concentration limit

■ Step 2
Select radionuclides with a larger magnitude of exposure as those subject to management

■ Steps 3 and 4
Set target discharge management values on past measurement results

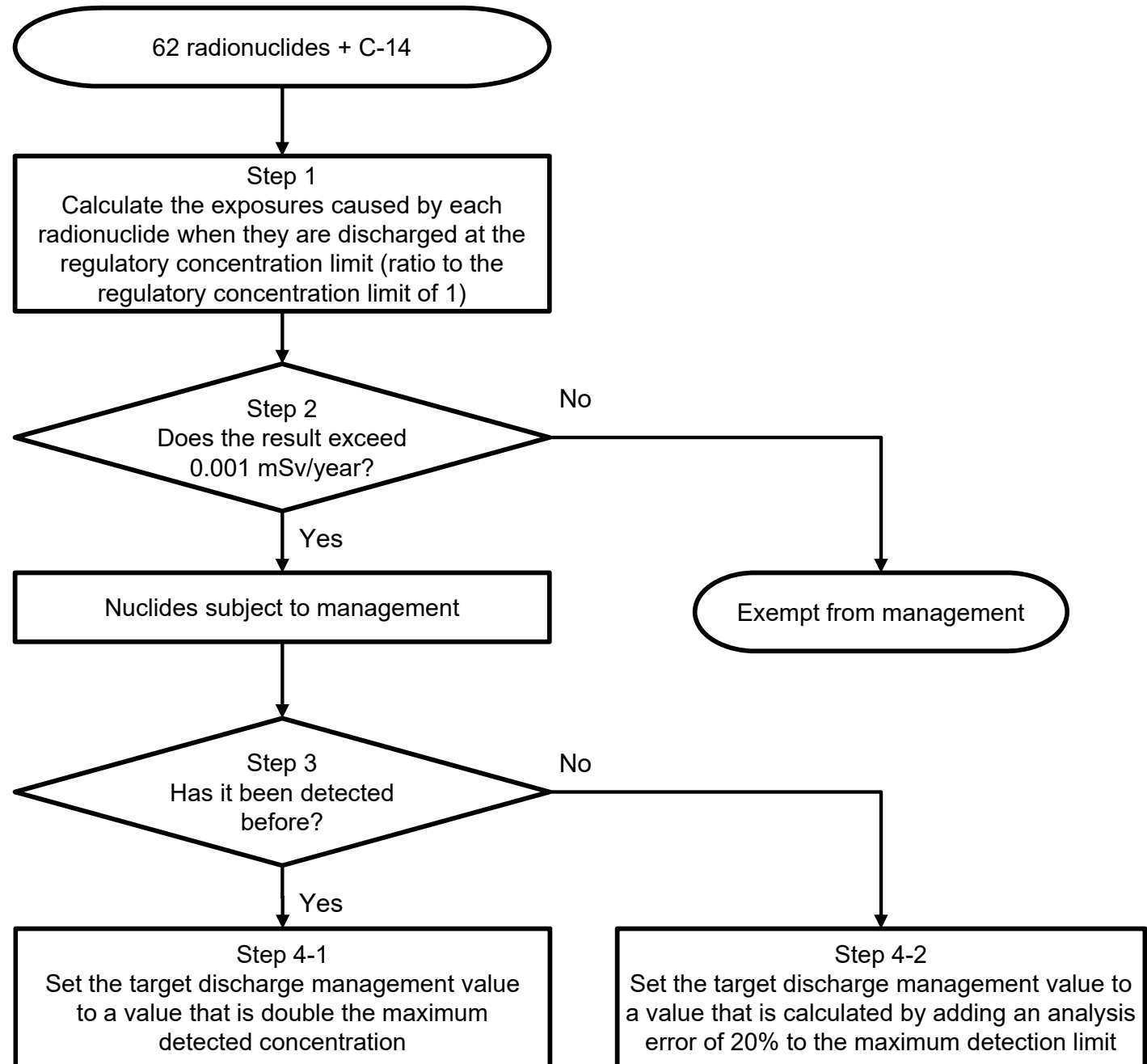

2-2(3) Radiological Impact Assessment on surrounding Environment due to Discharge into the Sea

2.7 Selection of radionuclides important to assessment and target discharge management values

- When selecting radionuclides subject to management, external exposures and effects on environmental protection each nuclide may have when discharged at the regulatory concentration limit were also studied in order to check for radionuclides that should be added to the control list.
- Although the external exposures of Te-127, Eu-155, and Gd-153 exceeded 0.001 mSv/year, it was judged that they could be exempt from management because all of them were calculated using the dose conversion coefficients for Co-60 in a conservative manner, and the calculated exposures are only slightly over 0.001 mSv/year.
- As for plants and animals, even the exposure results of Fe-59, which are the largest, are below the standard value (the derived consideration reference level), and it is already included in the radionuclides subject to management. In addition, the dose rates of other nuclides are lower than those of Fe-59 by more than one order of magnitude. Considering the above, it was judged that they could be exempt from management.

Table 1: Results of external exposure assessment when each nuclide is discharged at the regulatory concentration limit (fishing nets)

	Target nuclide	regulatory concentration limit [Bq/L]	Exposure from fishing nets [mSv/year]	Notes
1	Te-127	5.0E+03	2.1E-03	Dose conversion factors for Co 60 were used
2	Eu-155	3.0E+03	1.3E-03	Dose conversion factors for Co 60 were used
3	Gd-153	3.0E+03	1.3E-03	Dose conversion factors for Co 60 were used
4	Sn-119m	2.0E+03	8.5E-04	Subject to management

- All values were conservatively calculated using dose conversion factors for Co-60, and actual exposures are smaller than the values.
- Calculated exposures are only slightly over 0.001 mSv/year

 -> Judged that they do not need the setting of target discharge management values

Table 2: Results of Assessment for Environmental Protection when each nuclide is discharged at the regulatory concentration limit

	Nuclide	Regulatory concentration limit [Bq/L]	Exposure assessment result (mGy/day)			Notes
			Flat fish	Crab	Brown alga	
1	Fe-59	4.0E+02	5.4E-01	5.4E-01	5.8E-01	Subject to management
2	Sn-126	2.0E+02	9.7E-03	9.3E-03	9.0E-03	Subject to management
3	Pm-148m	5.0E+02	7.5E-03	7.2E-03	8.1E-03	

Derived consideration reference levels (DCRLs)
 Flat fish: 1-10 mGy/day, crab: 10-100 mGy/day, brown algae: 1-10 mGy/day

- Fe-59 and Sn-126, which have the most significant effect on exposures, are already subject to management.
- Exposures caused by other nuclides are below 1/100 of the standard value (DCRLs).

 -> Judged that they do not need the setting of target discharge management values

2-2(3) Radiological Impact Assessment on surrounding Environment due to Discharge into the Sea

2.8 Modeling of dispersion and transfer after discharge (Calculation of dispersion in the sea)

- The assessment used a model that was found to be reproducible based on the repeatability calculations for the cesium concentration in seawater after the accident at the Fukushima Daiichi Nuclear Power Station.
- Calculations with higher resolutions were conducted so as to simulate the sea area near the power station in detail.

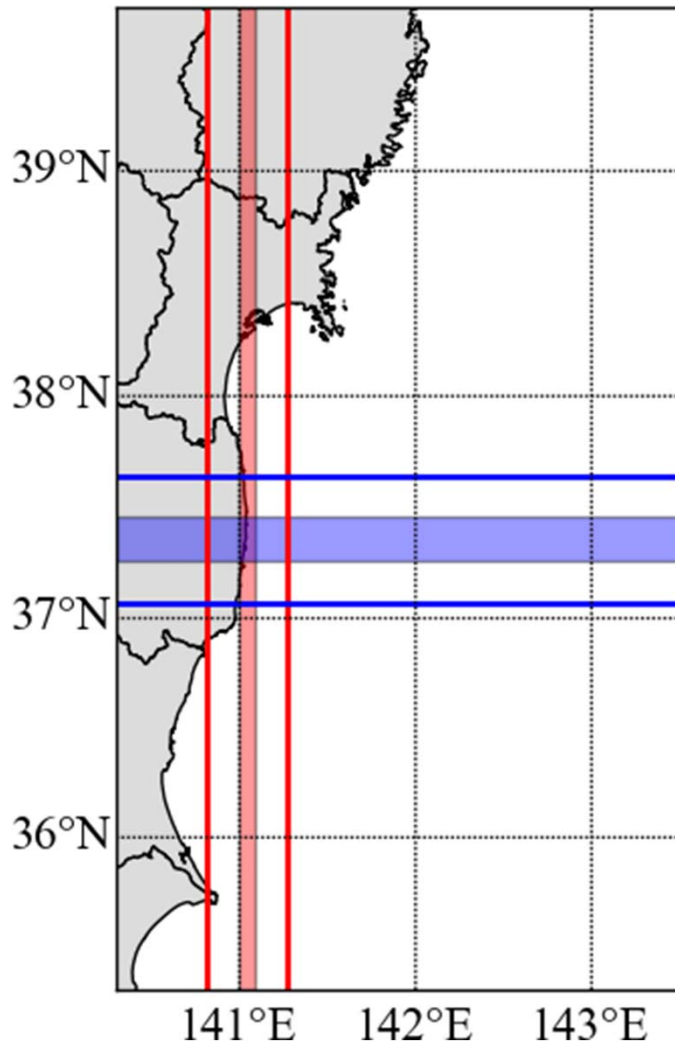

- Applied the Regional Ocean Modeling System (ROMS) to the sea area off the Fukushima coast
- Sea area flow data
 - Data into which JMA short-term weather forecast data (Global Spectral Model GPV) was interpolated^[1] was used as the sea surface driving force
 - Ocean reanalysis data (JCOPE2^[2]) was used as the source for boundary conditions for the open sea and data assimilation*
- Scope of modeling: The sea area 35.30-39.71° N, 140.30-143.50° E (490 km × 270 km), the area hatched by the red and blue lines (22.5 km north to south and 8.4 km east to west of the Power Station) is resolved step by step until the mesh size becomes 200 m.
 - Resolution (overall): NS approx. 925 m x EW approx. 735 m (approx. 1 km); 30 layers vertically
 - Resolution (immediate vicinity of the station): NS approx. 185 m x EW approx. 147 m (approx. 200 m); 30 layers vertically (the sea area hatched by red and blue in the diagram on the left)
- Meteorological and sea conditions data
 - Data of two years, in 2014 and 2019

*Data assimilation: a method for incorporating actual measurements in numerical simulations. Also known as nudging.

[1] A. Hashimoto, H. Hirakuchi, Y. Toyoda, and K. Nakaya, "Prediction of regional climate change over Japan due to global warming (Part 1) - Evaluation of Numerical Weather Forecasting and Analysis System (NuWFAS) applied to a long-term climate simulation -" CRIEPI Report, 2010.

[2] Y. Miyazawa, R. Zhang, X. Guo, H. Tamura, D. Ambe, J.-S. Lee, A. Okuno, H. Yoshinari, T. Setou, and K. Komatsu, "Water mass variability in the western North Pacific detected in a 15-year eddy resolving ocean reanalysis," 2009.

2-2(3) Radiological Impact Assessment on Surrounding Environment due to Discharge into the Sea

Major issue (Validity of the dispersion model)

TEPCO

2.9 Modeling of dispersion and transfer after discharge (Validity of models)

- The model used for the dispersion calculation in the sea area has high reproducibility. To verify the model, calculations to reproduce the concentration in seawater of cesium leaked as a result of the accident at Fukushima Daiichi NPS were performed using the model based on actual past weather and sea conditions data, and the results were compared with actual measured data*.
- ✓ Fig. 1 shows the results of the simulation of changes in concentration are generally consistent with the results obtained by the monitoring.
- ✓ Fig. 2 shows the simulation results of the annual average concentration are generally in agreement with the measured results.
- ✓ In both figures, in the concentration range below 10 Bq/m³ (0.01 Bq/L), the observed values tend to exceed the simulation results, which is estimated to be the effect of inflow from outside that is not covered by the simulation.

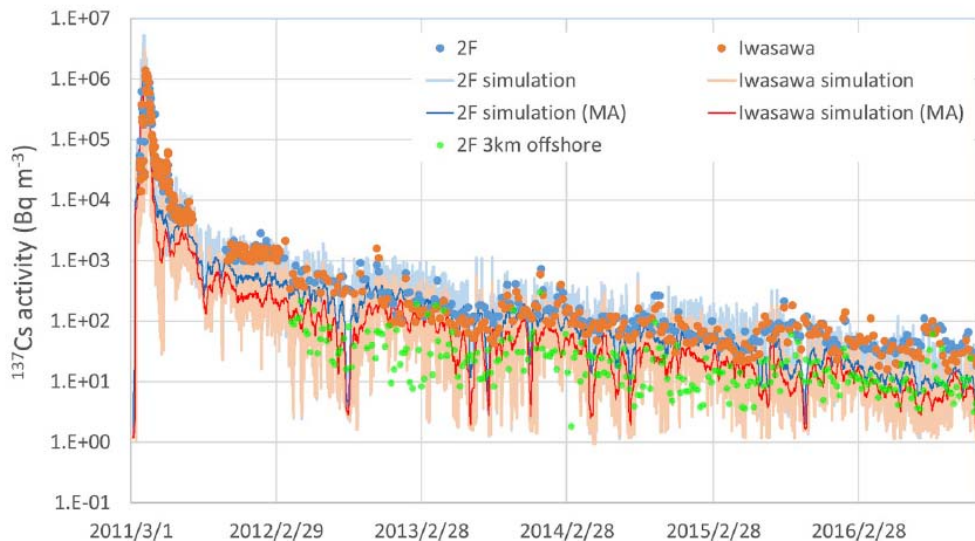

Fig. 1: Comparison of the calculated Cs-137 concentrations near Iwasawa, Fukushima Daiichi, with monitoring results (MA) is the 14 day moving average.

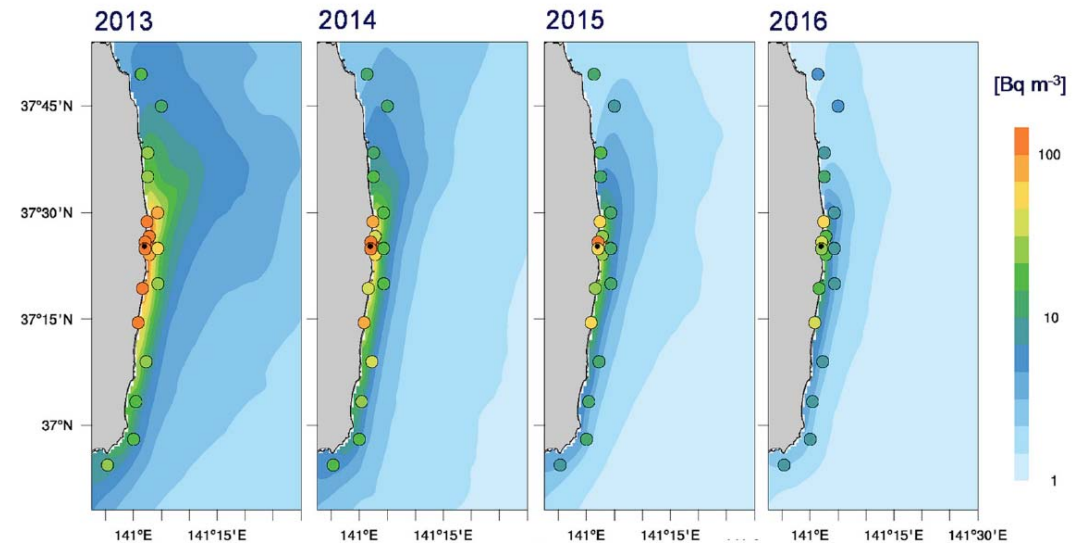

Fig. 2. Comparison of calculated annual Cs-137 concentrations in the sea area around Fukushima Daiichi with monitoring results ○ marks represent monitoring points.

* D.Tsumune, T.Tsubono, K.Misumi, Y.Tateda, Y.Toyoda, Y.Onda, and M.Aoyama, "Impacts of direct discharge and river discharge on oceanic 137Cs derived from the Fukushima Dai-ichi Nuclear Power Plant accident", 2020.

2-2(3) Radiological Impact Assessment on surrounding environment due to discharge into the sea

2.10 Modeling of dispersion and transfer after discharge (Transfer pathways)

- Radioactive materials discharged into the sea are estimated to transfer through the following pathways, and those covered by this modeling were determined while referring to assessments performed in the past in Japan (power stations, reprocessing plants).
- Regarding external exposures, exposures due to gamma rays, which will lead to greater doses, were selected as the target.

	Transfer pathway	Selection of transfer pathways	Rationale
(1)	Direct radiation from the facilities	Exempt	The ALPS Treated Water to be handled by the facilities is water from which radioactive materials other than tritium have been removed to a level allowable for discharge, so there is no need to take into account the exposure due to direct radiation.
(2)	Advection and dispersion due to ocean currents, etc.	Selected (Humans and environmental protection)	The advection and dispersion of radioactive materials discharged into the sea are selected because it is the base pathway for all transfer pathways.
(3)	Advection and dispersion due to ocean currents, etc.→ Transfer to ship bodies (adhesion)	Selected (Humans)	It was determined to select this pathway while referring to a similar assessment (Dose assessment for the general public in the safety review for light-water nuclear power reactor facilities).
(4)	Advection and dispersion due to ocean currents, etc.→ Transfer to fishing nets (adhesion)	Selected (Humans)	It was determined to select this pathway while referring to a similar assessment (Dose assessment for the general public in the safety review for light-water nuclear power reactor facilities).
(5)	Advection and dispersion due to ocean currents, etc.→ Transfer to beach sand	Selected (Humans)	It was determined to select this pathway while referring to a similar assessment (Dose assessment for the general public in the safety review for light-water nuclear power reactor facilities).
(6)	Advection and dispersion due to ocean currents, etc.→ Transfer to marine organisms (intake, concentration)	Selected (Humans and environmental protection)	It was determined to select this pathway while referring to a similar assessment (Dose assessment for the general public in the safety review for light-water nuclear power reactor facilities), and because this is the primary pathway to marine plants and animals.
(7)	Advection and dispersion due to ocean currents, etc.→ Transfer to seabed soil	Selected (Environmental protection)	It was determined to select this pathway because this is a major pathway to habitats for marine plants and animals.
(8)	Advection and dispersion due to ocean currents, etc.→ Transfer to the air (evaporation, dispersion)	Exempt	This pathway was exempt because the amount of radioactive materials transferred to the air through evaporation and dispersion is negligible and is not taken into account in other similar assessments.

2-2(3) Radiological Impact Assessment on surrounding environment due to discharge into the sea

Major issue (completeness of exposure pathways)

TEPCO

2.11 Exposure pathways and transfer models (1) Exposure pathways

- Exposure pathways to the selected person are as follows:
 - (1) External exposure during work on the sea (Exposure from seawater)
 - (2) External exposure during work on the sea (Exposure from ship bodies)
 - (3) External exposure during swimming and undersea work
 - (4) External exposure at beaches (Exposure from sandy beaches)
 - (5) External exposure from fishing nets
 - (6) Internal exposure from ingestion of seafood

How to calculate external exposures

- Exposure due to radiation from the sea when moving by boat or working underwater.

$$\begin{aligned} \text{Amount of exposure} &= \text{Effective dose conversion coefficient} \\ &\times \text{Concentration of radioactive materials in seawater} \end{aligned}$$

- Exposure due to radiation from the radioactive materials that have transferred from seawater to ship bodies, sand on beaches, and fishing nets

$$\begin{aligned} \text{Amount of exposure} &= \text{Effective dose conversion coefficient} \times \text{Transfer coefficient} \\ &\times \text{Concentration of radioactive materials in seawater} \end{aligned}$$

- The Handbook on Environmental Impact Assessment for Decommissioning Work^{*1} (hereinafter referred to as Decommissioning Handbook) summarizes parameters for assessing impacts on the general public caused by radioactive waste and liquid waste that might generate from each step of the decommissioning work.
- Coefficients presented by the Decommissioning Handbook were used for assessing external exposures.
- The transfer coefficient from seawater to ship bodies, etc., is the coefficient specified in the documents for the application for the designation of the Rokkasho Reprocessing Plant as a reprocessing business^{*2}. Only the coefficient for the transfer to sand beaches is derived from guidelines by the former Nuclear Safety Commission^{*3}.
- When the effective dose conversion coefficient for a radionuclide is not defined in the Decommissioning Handbook, the most conservative effective dose conversion coefficient was adopted: coefficient for Co-60 for $\beta\gamma$ nuclides and that for Am-243 for α nuclides.

*1 "Survey on Environmental Impact Assessment Technology for Decommissioning of Commercial Reactors - Survey on Environmental Impact Assessment Parameters (FY2006 Survey Commissioned by Ministry of Economy, Trade and Industry) Appendix: Handbook on Environmental Impact Assessment for Decommissioning Work" Central Research Institute of Electric Power Industry

*2 "Application for Designation of the Rokkasho Reprocessing Plant as a Reprocessing Business", Japan Nuclear Fuel Limited

*3 "Dose assessment for the general public in the safety assessment of light-water power reactor facilities", Nuclear Safety Commission

*4 EPA FEDERAL GUIDANCE REPORT NO. 15 "EXTERNAL EXPOSURE TO RADIONUCLIDES IN AIR, WATER AND SOIL"

*5 ICRP Pub.144 "Dose Coefficients for External Exposure to Environmental Sources"

2-2(3) Radiological Impact Assessment on surrounding Environment due to Discharge into the Sea

2.13 Exposure pathways and transfer models (3) External exposures calculation models

- The models for the calculation of effective dose conversion coefficients defined in the Decommissioning Handbook are as follows: QAD-CG2P2, a simple shielding calculation code, is used for calculations.

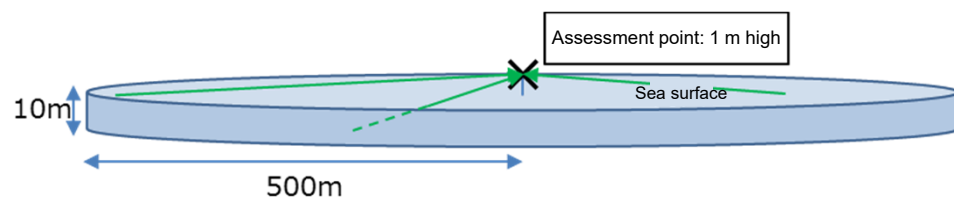

Assessment model for exposure from the surface of the sea

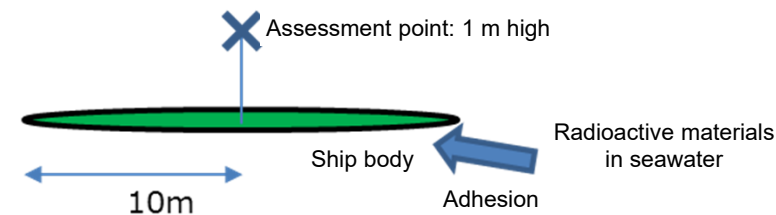

Assessment model for exposure from ship bodies

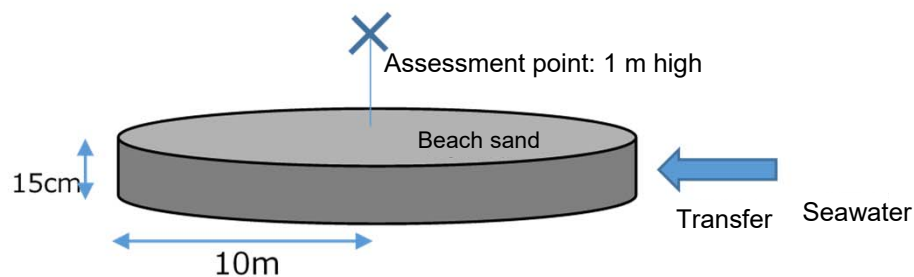

Assessment model for exposure from sand beaches

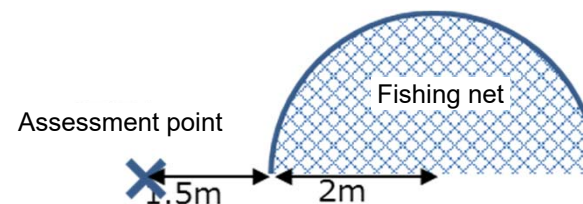

Assessment model for exposure from fishing nets

- Only the calculation of external exposure during swimming uses the submersion model.

2-2(3) Radiological Impact Assessment on surrounding environment due to discharge into the sea

Major issue (completeness of exposure pathways)

TEPCO

2.14 Exposure pathways and transfer models (4) Internal exposure pathways

- As pathways for internal exposures, exposures from the ingestion of seafood were selected, as with other facilities that discharge radioactive liquid waste into the sea.

Calculation formula for internal exposures

Amount of exposure = Effective dose coefficient × Ingestion rate

Ingestion rate = Concentration of radioactive materials in seawater × Concentration coefficient
× Amount of seafood ingested annually

- As effective dose coefficients, parameters for adults (20 years and older), young children (5 years), and babies (3 months) derived from ICRP Pub. 72*1 are used.
- Daughter nuclides that have attained radioactive equilibrium are assumed to be taken in at the same concentration as their parent nuclides.
- The concentration coefficients used for fish, invertebrates, and seaweeds are those specified in IAEA TRS No.422.*2 (Only the factor for Rb is derived from UCRL -50564*3)
- Dilution at the market and decay of radioactive materials during the period from the collection and ingestion of seafood are not taken into account.

*1 ICRP Pub.72, "Age-dependent Doses to Members of the Public from Intake of Radionuclides; Part 5 Compilation of Ingestion and Inhalation Doses Coefficients"

*2 IAEA Technical Report Series No.422, "Sediment Distribution Coefficients and Concentration Factors for Biota in the Marine Environment"

*3 UCRL-50564rev.1 "CONCENTRATION FACTORS OF CHEMICAL ELEMENTS IN EDIBLE AQUATIC ORGANISM," LAWRENCE LIVERMORE LABORATORY, 1972.

2.15 Identification of the representative person

- Since it is difficult to simulate lifestyle habits in areas near the Fukushima Daiichi NPS, which are currently under restoration, cases of other domestic nuclear power plants were referred to, and the following individuals are assumed to be exposed to radiation.
 - Individuals who live in the vicinity of Fukushima Daiichi NPS and use the coast for recreation, etc.
 - Individuals who are engaged in fishery in the sea area around the Fukushima Daiichi NPS
 - Individuals who eat seafood from the waters around the Fukushima Daiichi NPS
- The specific lifestyle habits were set as follows based on “Dose assessment for the general public in the safety review for light-water nuclear power reactor facilities”, and a person who is to be exposed to radiation from all exposure pathways was selected as the representative person.
 - A person engaged in fisheries for 2880 hours a year, of which 1920 hours are operations near fishing nets.
 - A person who spends 500 hours on the beach a year and swims in the sea for 96 hours.
- As for the ingestion of seafood, two cases were set while referring to the food-by-food ingestion by adults reported in the National Health and Nutrition Survey in 2019 issued by the Ministry of Health, Labor and Welfare: ingestion of the average amount and ingestion of a larger amount (average + 2 σ). The ingestions by young children and babies were set at 1/2 and 1/5 of the ingestion by adults, respectively, based on the “Guidelines for the assessment of doses in the vicinity of light-water nuclear power reactor facilities against dose target values”.

Table 1. ingestion by individuals who ingest the average amount of seafood (g/day)

	Fish	Invertebrates	Seaweeds
Adult	58	10	11
Young children	29	5.1	5.3
Baby	12	2.0	2.1

Table 2. ingestion by individuals who ingest a larger amount of seafood (g/day)

	Fish	Invertebrates	Seaweeds
Adult	190	62	52
Young children	97	31	26
Baby	39	12	10

- Four doses were calculated (3 source terms based on measured values, and a source term based on the hypothetical ALPS treated water).
- External exposures were calculated for adults only.
- Internal exposures were calculated for adults, young children, and babies, respectively, while dividing them into two categories: those who take in the average amount of seafood and those who take in a more significant amount.
- The estimated exposure dose of the representative person is the sum of the external and internal exposures (adults).
- According to IAEA GSG-10, the estimated dose should be compared with the dose limit and dose constraints to the general public. Since the Japanese government, however, has not set dose constraints, the estimated value was compared with the exposure dose target for light water reactors (0.05 mSv/year).

2-2(3) Radiological Impact Assessment on surrounding Environment due to Discharge into the Sea

2.17 Tritium dispersion calculation result (Distribution of annual average concentration on the surface of the sea)

- This distribution was evaluated using the meteorological and sea condition data in 2019 under the condition that 22 trillion Bq tritium is discharged evenly throughout a year. The result shows that the area where the annual average concentration on the sea surface exceeds 1 Bq/L* is within 2 to 3 km from the power station.

*1/10,000 of the value specified in the WHO Guidelines for Drinking-water Quality (10,000 Bq/L).

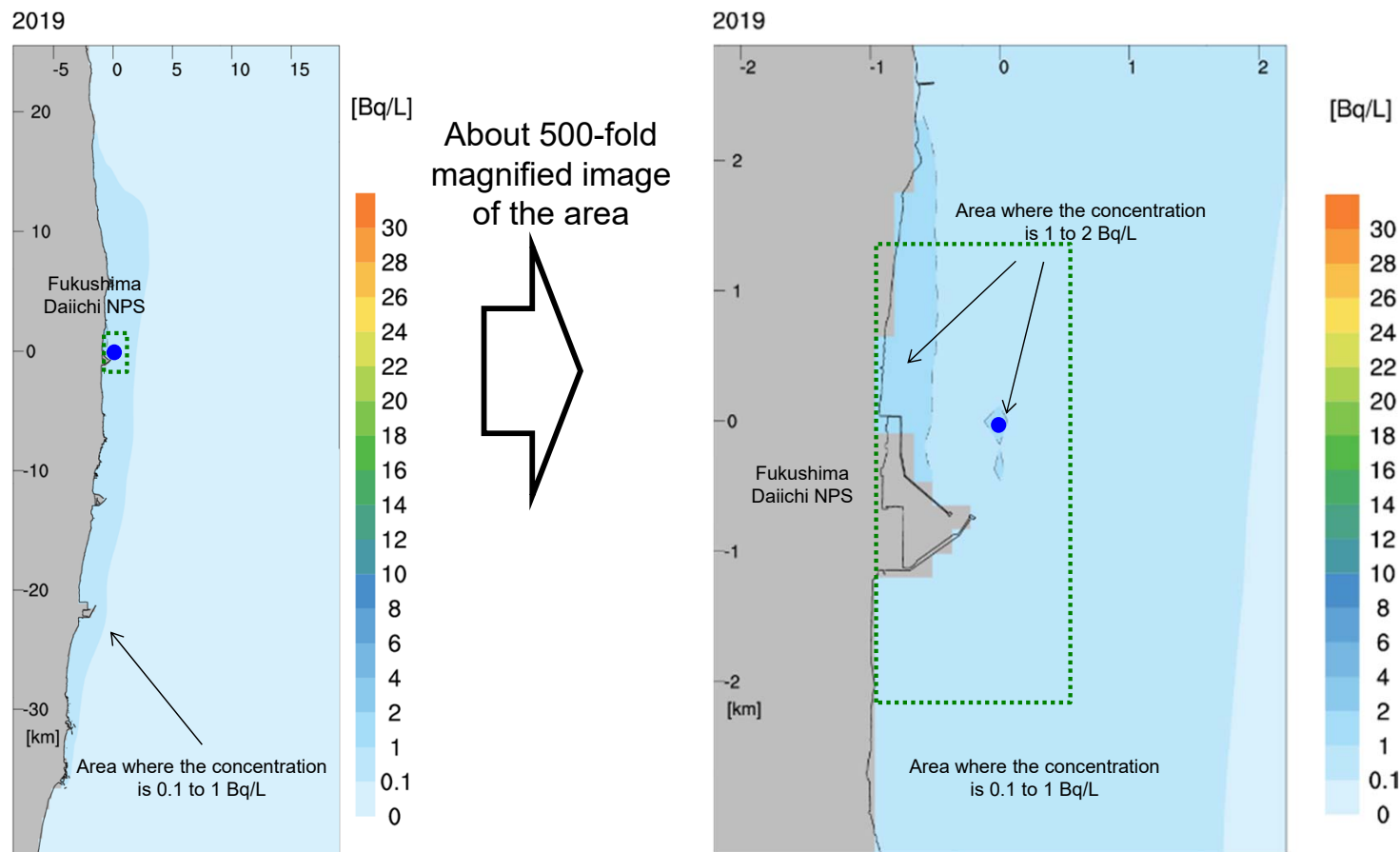

Magnified image of the offshore of Fukushima Prefecture

Magnified image of the area around the power station

- Concentration results of about 30 Bq/L were confirmed just above the outlet of the tunnel, before the water diffuses, but the concentration decreases rapidly around there.
- Before ALPS Treated Water is discharged, it will be diluted with seawater 100 times or more until the tritium concentration becomes less than 1,500 Bq/L. Even the concentration just above the tunnel outlet is much lower than the limit set by domestic regulations (60,000 Bq/L), which was established in line with ICRP Recommendations, and the value set by the WHO Guidelines for Drinking-water Quality (10,000 Bq/L).

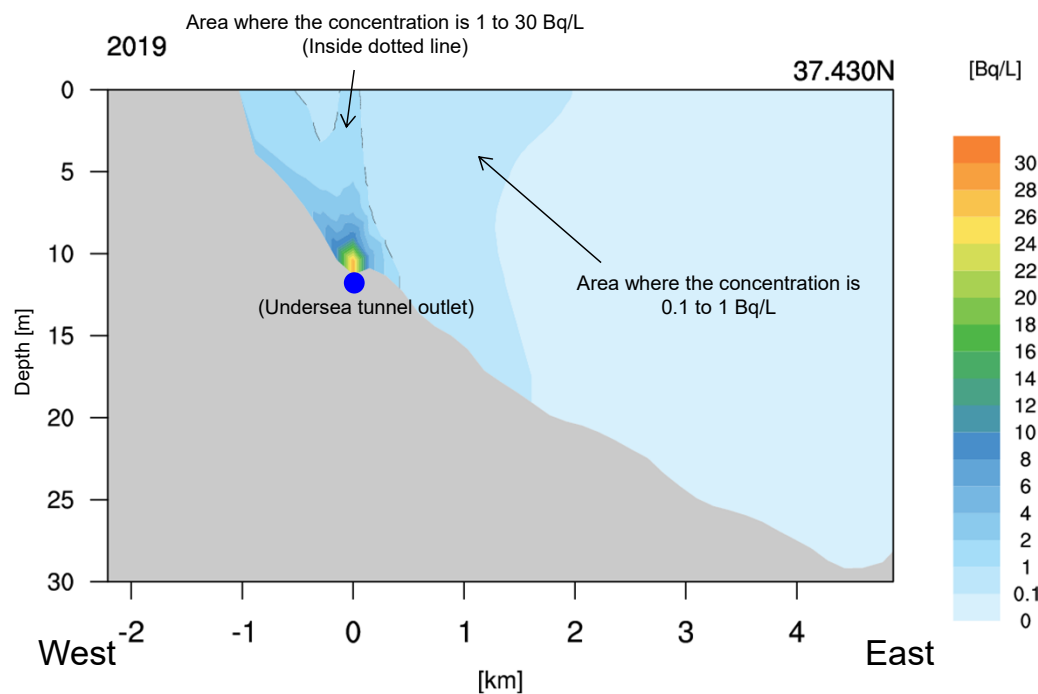

East-west cross section of the tunnel outlet
(Drawing with a scale to the maximum of 30 Bq/L)

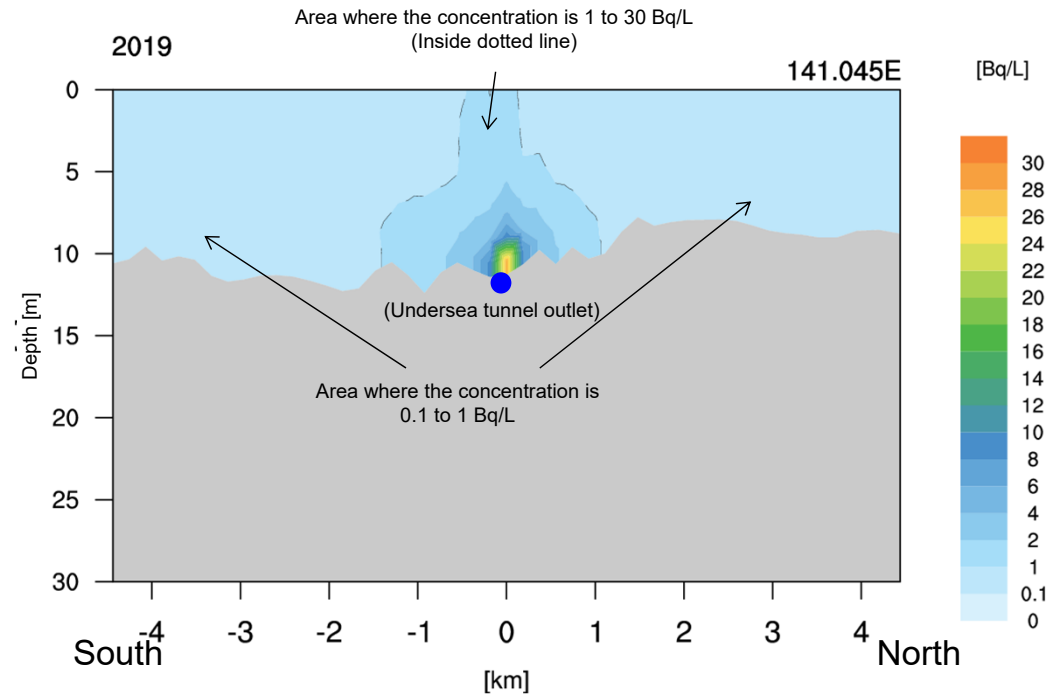

North-south cross section of the tunnel outlet
(Drawing with a scale to the maximum of 30 Bq/L)

2-2(3) Radiological Impact Assessment on surrounding Environment due to Discharge into the Sea

2.19 Concentrations of radioactive materials used in the exposure assessment

- The concentrations of the other 63 radioactive materials in seawater used for the assessment were calculated using the calculated tritium concentration and the proportions of each nuclide in the discharged treated water.
- Considering the area subject to external exposures and the area where seafood, which is the cause of internal exposures, is collected, the annual average concentrations in the area of 10 km × 10 km were used as the concentrations of radioactive materials in the seawater for the assessment.
- ✓ The individuals subject to the radiation exposure assessment are those engaged in fishing and eat seafood from the sea around the power station.
- ✓ The external exposure during work is determined by the concentration of radioactive materials in the seawater of the worksite and the operation hours. Still, the exposure throughout a year can be assessed using the average concentration in the entire operation area.
- ✓ Since operations will be carried out over a wide area around the fishing port, external exposures from seawater, etc., should be calculated from the concentrations of radioactive materials in seawater in the broader area. The assessment this time conservatively assumed that the operations are carried out only within an area of 10 km × 10 km around the power station, and the annual average concentrations in seawater within the 10 km × 10 km area were used.
- ✓ In the same way, as regards the ingestion of seafood, only seafood from the 10 km × 10 km area was assumed to be taken in to obtain a conservative result.



*Area where common fishery rights are not set.

Area diagram for calculating the radiation material concentration in the sea to be used in the assessment

Source: This map was created by Tokyo Electric Power Company Holdings, Inc. based on a map published by the Geographical Survey Institute (Electronic Map Web) <https://maps.gsi.go.jp/#13/37.422730/141.044970/&base=std&ls=std&disp=1&vs=c1j0h0k0l0u0t0z0r0s0m0f1>

2-2(3) Radiological Impact Assessment on surrounding Environment due to Discharge into the Sea

2.20 Human exposures assessment results (Estimated exposures to the representative person)



- The table below shows the assessment results of exposures to the representative person. Even in the assessment case of individuals who ingest a larger amount of seafood in which the source terms were determined based on the most conservatively hypothesized ALPS treated water, the results are much lower than the dose target of 0.05 mSv/year and the dose limit of 1 mSv/year.

Table: Human exposures assessment results (representative person)

Assessment case	Source term	(1) Source term based on measured values						(2) Source term based on hypothetical ALPS treated water	
		i. K4 tank groups		ii. J1-C tank groups		iii. J1-G tank groups			
	ingestion of seafood	Average	More than average	Average	More than average	Average	More than average	Average	More than average
External exposure (mSv/year)	Sea surface	6.5E-09		1.7E-08		4.7E-08		1.8E-07	
	Ship body	5.2E-09		1.3E-08		3.4E-08		1.4E-07	
	Swimming	2.8E-10		7.6E-10		2.0E-09		7.9E-09	
	Beach sand	5.0E-07		1.3E-06		3.6E-06		1.4E-05	
	Fishing net	1.6E-06		4.3E-06		1.2E-05		4.5E-05	
Internal exposure (mSv/year)		1.5E-05	6.1E-05	2.8E-05	1.1E-04	7.9E-05	3.0E-04	4.8E-04	2.0E-03
Total (mSv/year)		1.7E-05	6.3E-05	3.4E-05	1.1E-04	9.4E-05	3.1E-04	5.4E-04	2.1E-03

2.21 Human exposure assessment results (Estimated internal exposures by age)

- The table below shows the assessment results of internal exposures by age. Although the internal exposures to young children and babies, for whom larger effective dose coefficients are set, are larger than the results for adults, even in the assessment case of individuals who ingest a larger amount of seafood in which the source terms were determined based on the most conservatively hypothesized ALPS treated water, the results are much lower than the dose target of 0.05 mSv/year and the dose limit of 1 mSv/year.

Table: Internal exposures assessment results by age

Assessment case	Source term	(1) Source term based on measured values						(2) Source term based on hypothetical ALPS treated water	
		i. K4 tank groups		ii. J1-C tank groups		iii. J1-G tank groups			
	ingestion of seafood	Average	More than average	Average	More than average	Average	More than average	Average	More than average
Internal exposure (mSv/year)	Adult	1.5E-05	6.1E-05	2.8E-05	1.1E-04	7.9E-05	3.0E-04	4.8E-04	2.0E-03
	Young children	2.4E-05	9.4E-05	5.1E-05	2.0E-04	1.5E-04	5.6E-04	7.5E-04	3.1E-03
	Baby	2.9E-05	1.1E-04	6.7E-05	2.5E-04	1.9E-04	7.1E-04	9.4E-04	3.9E-03

3. Assessment for Environmental Protection

3.1 Approach to the Assessment for Environmental Protection

- Assessment for the protection of plants and animals during normal operation was performed in accordance with the procedures described in Appendix I of IAEA GSG-10.

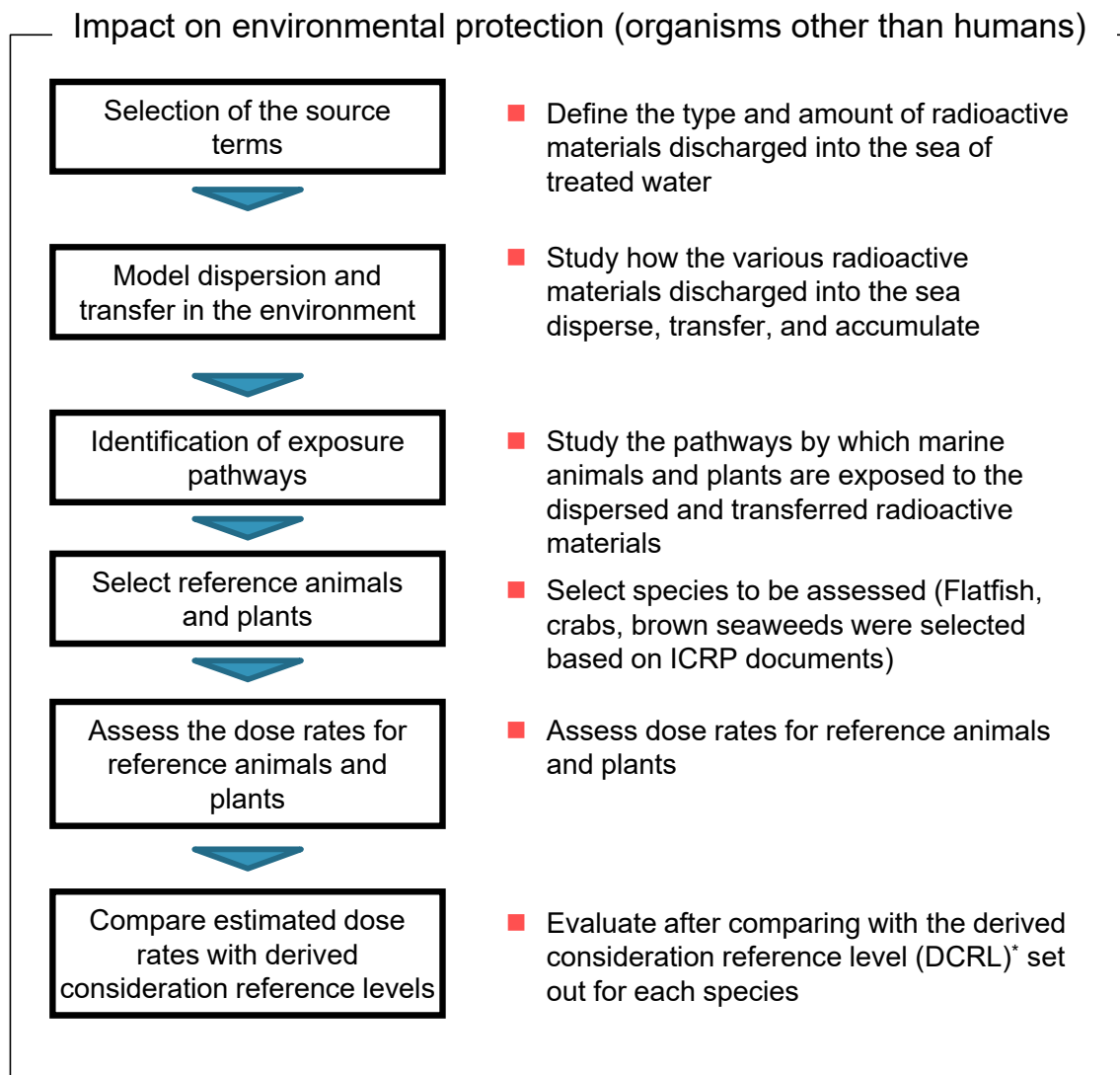

* Induction Consideration Reference Level (DCRLs): A band of dose rates with a single-digit range defined by the ICRP for each species of organisms.

If an assessment result falls within the range of the DCRL, the impacts must be taken into account.

3.2 Setting of the source term

- The source terms of environmental impact assessment were set based on the same rationale as those for the assessment of human exposures.
- ✓ The source terms based on measured values are the same as those for the assessment of human exposures.
- ✓ As the source terms based on the hypothetical ALPS treated water, the annual discharges were set while assuming that the two radionuclides subject to management, Fe-59 and Sn-126, which have relatively significant impacts on the exposures and selected for the Assessment for Environmental Protection, are contained at their target discharge management values (ratio to regulatory concentration limit: 0.0025), and as the radionuclide representing the other 62 nuclides, promethium-148m is contained at 499 Bq/L (ratio to regulatory concentration limit: 0.9975).
- of

Table: Source terms (excluding tritium) based on hypothetical ALPS Treated Water used for the Assessment for Environmental Protection

Target nuclide	Regulatory concentration (Bq/L)	Concentration of the nuclide (Bq/L)	Ratio to regulatory concentration limit	Annual discharge of water (L)	Annual discharge (Bq)	Notes
Fe-59	4.0E+02	2.0E-01	0.0005	2.2E+08	4.4E+07	Subject to management
Sn-126	2.0E+02	4.0E-01	0.002		8.8E+07	Subject to management
Pm-148m	5.0E+02	5.0E+02	0.9975		1.1E+11	
Sum of the ratios of radionuclides other than tritium			1			

- As dispersion models in the ocean, the same models as those used for the assessment of human exposures were used.
- As transfer pathways, the transfer to the seabed sediment, which is important in assessing exposures of marine plants and animals, was selected as well as advection and dispersion due to ocean currents. Direct radiation and transfer into the air were not taken into account for the same reason as in the assessment of human exposures.
- The following exposure pathways affecting exposures under the sea were selected from among pathways defined in IAEA GSG-10 as those that need to be considered when assessing doses to plants and animals.
 - ✓ External exposure due to radioactive materials in water and sediment
 - ✓ Internal exposure from radioactive materials absorbed by plants or ingested or inhaled by animals
- The concentrations of the other 63 radioactive materials in seawater used for the assessment were calculated using the calculated tritium concentration and the proportions of each nuclide in the discharged treated water.
- While the area subject to assessment defined by GSG-10 is an area of 100 to 400 km², the area assessed this time was 100 km² (10 km × 10 km). The annual average concentration in seawater within the 10 km × 10 km area was used for the exposure assessment.
- When assessing the dispersion in the seawater, a decrease in radioactive materials due to transfer to sediment, plants and animals was not taken into account. On the other hand, in the exposure assessment, transfer to sediment and concentration ratio in organisms are assumed to be in an equilibrium state.

3.4 Select reference animals and plants

- In the same way as the representative person in the assessment of human exposures, all of the reference flatfish, reference crab, and reference brown seaweed were selected as plants and animals subject to the exposure assessment from among the reference plants and animals in the ocean environment that are specified in ICRP Pub. 136*.
 - Flatfish: Flounders widely inhabit the surrounding sea area and are important fish for the local fishery industry.
 - Crab: Many types of crabs (e.g., *Portunus trituberculatus*, *ovalipes punctatus*) widely inhabit the surrounding sea area
 - Brown seaweeds: Many types of seaweed, including gulfweed and sea oak, widely inhabit the surrounding sea area

- Since these plants and animals live near the seabed, the annual average concentrations of radioactive materials in the undermost layer of seawater were used for the exposure assessment.

* ICRP Pub.136, ICRP, ICRP Publication 136 "Dose Coefficients for Non-human Biota Environmentally Exposed to Radiation",2017

Assessment method

- To assess impacts on plants and animals, dose rates in their habitats were calculated.
- ✓ The dose rates were calculated by the following formulae using the dose conversion coefficients for reference plants and animals specified by ICRP.
- ✓ As external exposures, exposures from seawater and sediment were considered.

Internal exposure = Internal dose conversion coefficient × Radiation material concentration in seawater
× Concentration ratio

External exposure = 0.5 × External dose conversion coefficient × Radiation material concentration in
seawater + 0.5 × External dose conversion coefficient × Radiation material
concentration in seawater × Partition coefficient

- The internal and external dose conversion coefficients specified in ICRP Pub. 136 and Biota DC*¹ were used, but radiation to Sn-126, which could not be calculated by Biota DC, was calculated using the value for Ru-106, the βγ nuclide that will result in the most conservative value.
- Concentration ratios were derived from ICRP Pub. 114*², but for elements that are not specified in it, the concentration coefficients of IAEA TRS-422*³ and the values for homologous elements shown in ICRP Pub. 114 were used.
- Distribution coefficients specified in IAEA TRS-422 (2.3. OCEAN MARGIN *K*_ds) were used.

Assessment criteria

- The results are compared with the Derived Consideration Reference Levels (DCRLs) published by the ICRP in Pub.124*⁴

*1 ICRP Biota DC Program v. 1.5. 1 (<http://biotadc.icrp.org/>)

*2 ICRP Pub.114, "Environmental Protection: Transfer Parameters for Reference Animals and Plants"

*3 IAEA Technical Report Series No.422, "Sediment Distribution Coefficients and Concentration Factors for Biota in the Marine Environment"

*4 ICRP Pub.124 "Protection of the Environment under Different Exposure Situations"

- The table below shows the calculated exposure doses of reference plants and animals. All dose rates are 1/100 or less of the lower limits of the derived consideration reference levels (DCRLs).

Table: Results of the Assessment for Environmental Protection

Assessment case		(1) Source term based on measured values			(2) Source term based on hypothetical ALPS treated water
		i. K4 tank groups	ii. J1-C tank groups	iii. J1-G tank groups	
Exposure (mGy/day)	Flat fish	1.7E-05	2.2E-05	5.6E-05	7.8E-03
	Crab	1.7E-05	2.2E-05	5.5E-05	7.5E-03
	Brown alga	1.9E-05	2.3E-05	5.9E-05	8.4E-03

Derived consideration reference levels (DCRLs)

Flat fish: 1-10 mGy/day, crab: 10-100 mGy/day, brown algae: 1-10 mGy/day

4. Assessment of potential exposures

2-2(3) radiological impact assessment on surrounding environment due to discharge into the sea

4.1 Assessment of potential exposures

- The potential exposure assessment in the report is evaluated taking the similar method of the flow chart illustrated in IAEA GSG-10, although the citation of it omits.
- Facilities that are taken into account when considering potential exposure scenarios are those down-stream from the Measurement/Confirmation facility shown in the figure below.

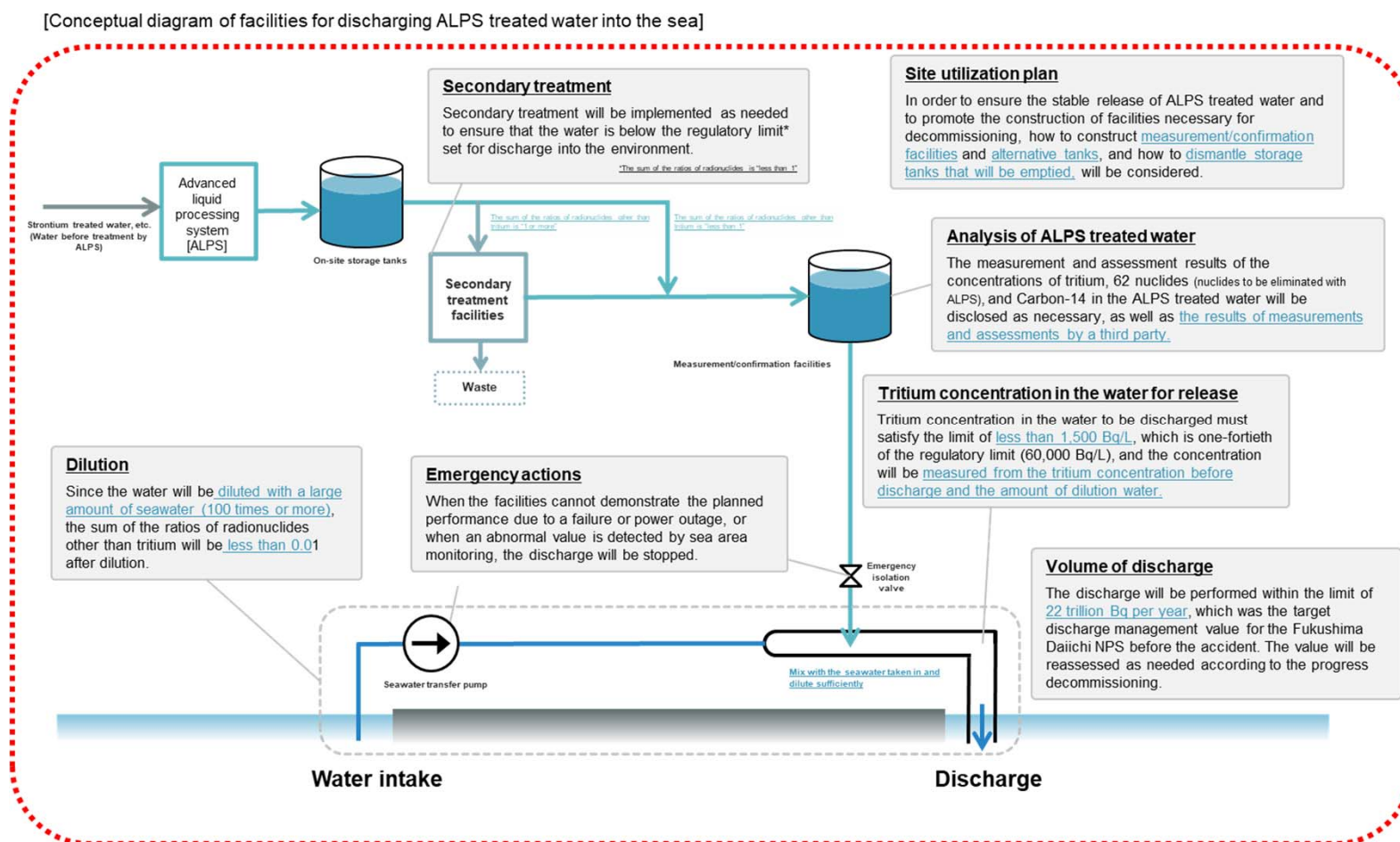

4.2 Approach to the assessment

- The procedures for the assessment of potential exposures described in IAEA GSG-10 are as follows:

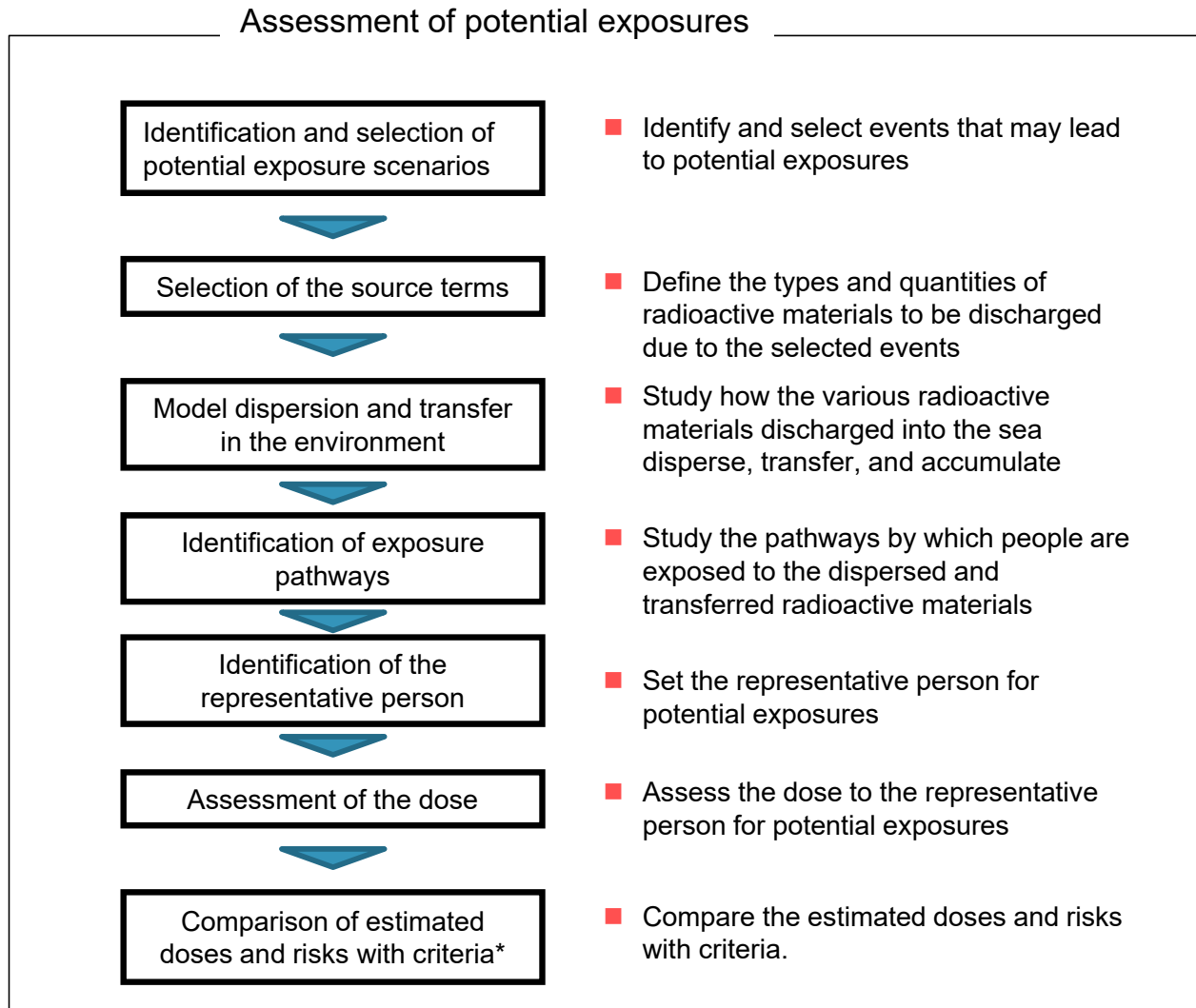

*IAEA GSG-10 gives 1 to several millisieverts (usually 5 mSv) as a criterion with which the comparison should be made.

- Scenarios were examined as follows, which are taking into account the outline of safety facilities described in the “Status of Review Regarding the Handling of ALPS Treated Water”, which was discharged by TEPCO on August 25 2021.
 - ✓ Some abnormal events can occur in facilities related to the discharge of the ALPS Treated Water into the sea, such as rupture of pipes, suspension of seawater pumps for dilution, etc. Even in the event of such an abnormality, **the water to be discharged from the outlet** will be **the ALPS Treated Water** that has been purified until the sum of the ratios of radionuclides other than tritium becomes less than 1 **or diluted ALPS treated water**.
 - ✓ Of the two, diluted ALPS Treated Water is subject to discharge, so the discharge of undiluted ALPS Treated Water is selected as the scenario.
 - ✓ Furthermore, to make the scenario the most severe, a case where ALPS Treated Water is discharged directly into the sea was assumed rather than events such as ruptures in pipes where ALPS Treated Water leaks within the site first and then is discharged into the sea. As a result, the selected scenario is as follows: the dilution seawater pump was stopped, but the emergency isolation valve did not function, leading to a discharge of undiluted ALPS Treated Water from the discharge outlet offshore.
 - ✓ Since the discharge of ALPS Treated Water is carried out on a tank group basis, discharge over a long period is unlikely to occur. Therefore, external exposures, which will be affected in the short period, were selected as the subject.

- The nuclide composition in the ALPS Treated Water to be discharged was hypothesized, and the source term was set as follows:
 - ✓ The assessment was performed while assuming a case with the maximum discharge rate of Te-127 (H-3 concentration is 100,000 Bq/L), which has the severest impact on external exposure from the sea surface.
 - ✓ Nuclide to be assessed: Te-127
 - ✓ Concentration: 5,000 Bq/L (regulatory concentration limit)
 - ✓ The discharge rate was calculated as follows using an ALPS Treated Water flow rate of 5,100 m³/day, the flow rate when the H-3 concentration of 100,000 Bq/L is diluted with seawater of 340,000 m³/day to 1,500 Bq/L (67 fold dilution).

$$5,000 \text{ Bq/L} \times 5,100 \text{ m}^3/\text{day} \times 1,000 \text{ L/m}^3 = 2.6 \text{ E} + 10 \text{ Bq/day}$$

- ✓ The designed discharge is up to 500 m³/day; thus, the value of 5,100 m³/day is a very conservative setting.

- The same simulation model as the one used in normal discharge was used to assess dispersion.
- As transfer pathways, advection and dispersion due to ocean current were selected. Since this case is a short-term discharge, the following exposures, which were considered in the exposure assessment during normal operation, were not taken into account: adhesion to ship bodies, beach sand, and fishing nets and accumulation in marine organisms such as fish and shellfish.
- As exposure pathways, exposures from the sea surface, which may cause long-term exposures, were selected.

- The representative person subject to the potential exposure assessment was assumed as follows.
 - ✓ A crew member of a vessel engaged in fishing and other operations in the vicinity of the power station when an abnormal discharge occurs.
 - ✓ Considering the north-south current in most areas around the power station, the fishing spot was set at a point that is outside the area where no fishing is conducted on a daily basis and closest to the discharge outlet in the north (about 1 km north).
 - ✓ Once an abnormal discharge occurs, they are supposed to suspend the operation and evacuate the area. Therefore, the duration they are exposed to radiation was assumed for one day (24 hours).
- As concentrations of radioactive materials in seawater to be used for the assessment, the maximum daily average concentrations at the point 1 km from the discharge outlet were calculated from the calculation data of two years, 2014 and 2019.
- The assessment method used is the same as the one used for the assessment of external exposures of humans from seawater during normal operation.

■ Assessment criteria

- ✓ The ALPS Treated Water is the water from which radioactive materials have been removed at the value less than 1 of the sum of ratios to regulatory concentration limit other than tritium. And the treated water will be discharged by tank group order. From these reasons, in case any accident at discharge works, only limited amount of radioactive materials will be discharged. Therefore, the standard value specified in GSG-10 as the value to be used generally, 5 mSv, was adopted as a criterion with which the estimated doses in the event of an accident should be compared.

■ Results of exposure assessment

- ✓ The estimated exposure dose was $7.3 \text{ E-}05$ mSv, which is much smaller than the criterion of 5 mSv in the event of an accident.

5. Terms Preparing for next Revisions

The table below shows terms to be revised at the time of submitting the amended application (as of this moment). Terms may be added or changed through briefings that will be given to the parties concerned.

Change of exposure pathways	<ul style="list-style-type: none">• Study to see if it is adequate to add exposure pathways in line with IAEA TECDOC-1759 (ingestion by drinking water while swimming, etc.)
Assessment using coefficients from other data sets	<p>In addition to the dose conversion coefficients, distribution coefficients, and concentration coefficients used this time, there are other coefficients available for some nuclides. Calculations will be performed on a trial basis using these coefficients to see how the use of different coefficients affects the assessment results.</p> <ul style="list-style-type: none">• IAEA TRS-479 (concentration ratio between seawater and marine organisms)• US EPA and ICRP Pub. 144 (Human external exposures)
Additional assessment	<ul style="list-style-type: none">• Study how the estimated exposure doses will be affected when organically bound tritium (OBT) is taken into account.• Study impacts on the outside of the dispersion simulation model used this time.• Study the identified abnormal events and how to respond to them (if necessary).
More detailed explanations regarding other points, etc.	<ul style="list-style-type: none">• Monitoring plan to be implemented by TEPCO (source monitoring, pre-discharge monitoring, sea area monitoring)• Study on the uncertainties in the assessment• Progress after the publication of this report that is made in the design and operation of facilities, etc.
Optimization of other descriptions	

Responses to major issues^(*) concerning the content of the application for the Discharge Facility of ALPS Treated Water into the Sea

*Document 1-2 for (The 3rd) Review Meeting on the Implementation Plan Regarding the Handling of ALPS Treated Water

(2-1 Major issues to be reviewed based on the Nuclear Reactor Regulation Act)

(1) Discharge Facility of ALPS Treated Water into the Sea

(5) Structure and strength of equipment, protection against natural phenomena such as earthquakes and tsunamis, prevention of misoperation, reliability, etc.

- The following points must be summarized and explained for each structure, system, and component consisting of the facilities for the discharge into the sea: safety functions, impacts in the event of the loss of safety functions, basic specifications, and the grounds for their establishment, the main structure, applicable standards, etc.

2-1 (1)(v) Structure and strength of equipment, protection against natural phenomena such as earthquakes and tsunamis, prevention of misoperation, reliability, etc.

- This section summarizes the structure and strength of equipment, protection against natural phenomena on facilities with safety functions composing the ALPS Treated Water Dilution/Discharge Facilities (excluding the discharge vertical shaft (upper-stream storage)).
- As for the discharge vertical shaft (upper-stream storage) and Discharge Facility, explanations will be made as soon as they are summarized.

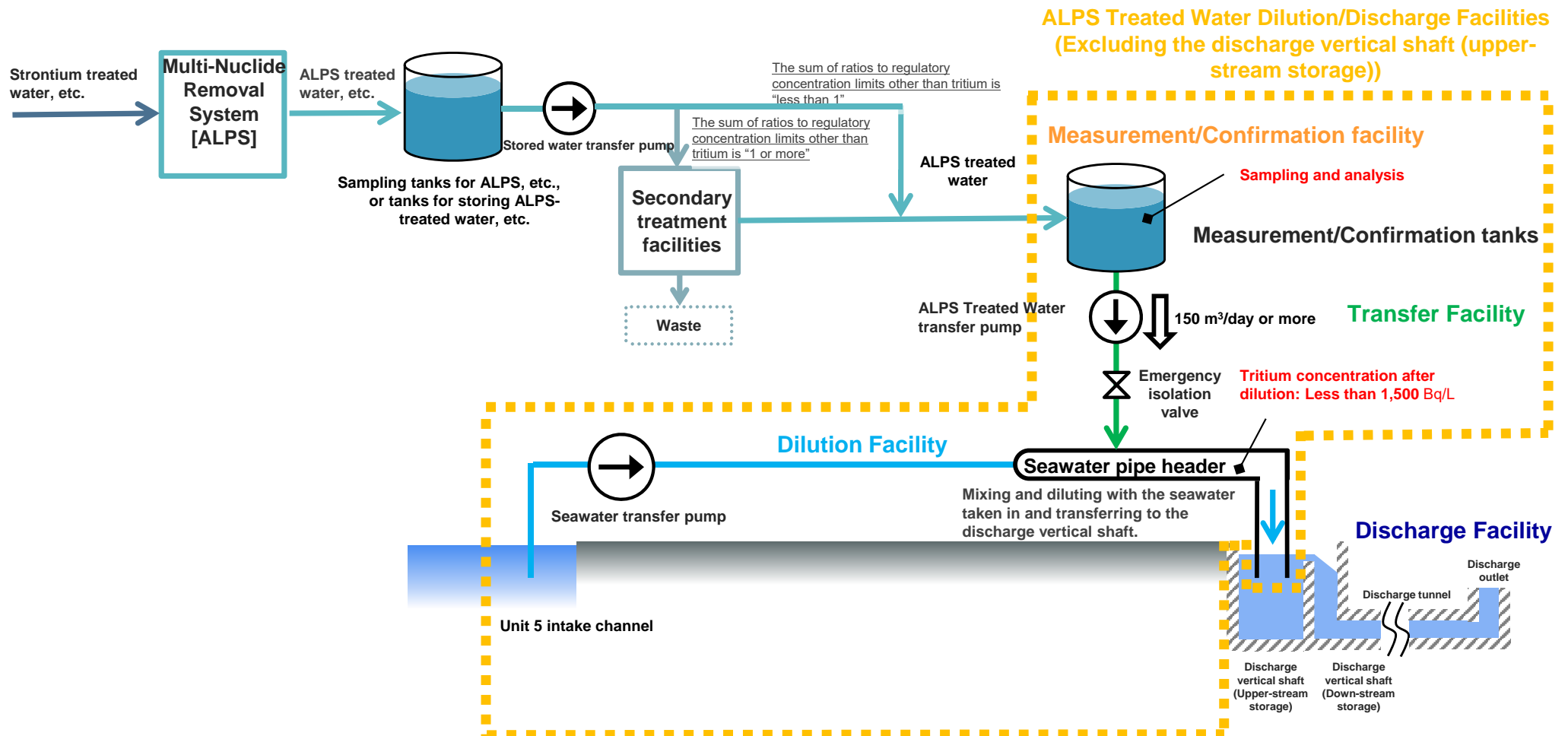

2-1 (1) (v) Structure and strength of equipment, protection against natural phenomena such as earthquakes and tsunamis, etc.

1. Applicable standards

“14. Design considerations (1) Applicable standards”

- The designing, selection of materials, manufacturing and inspections of structures, systems and components having safety functions shall comply with standards and criteria deemed appropriate to the importance of the safety functions they should perform.

- Codes for Nuclear Power Generation Facilities - Rules on Design and Construction for Nuclear Power Plants (JSME), Japan Industrial Standards (JIS), and other standards* are applied to the designing, selection of materials, manufacturing, and inspections in order to ensure the reliability.

- *: “JIS G 3454 Carbon steel pipes for pressure service”, “JIS G 3457 Arc welded carbon steel pipes”, “JIS G 3459 Stainless steel pipes”, “JIS G 3468 Large diameter welded stainless steel pipes”, and “JWWA K 144 Polyethylene pipes for water supply”
(Implementation Plan II-2-50-3)

- Major equipment containing ALPS Treated Water that comprises the ALPS Treated Water Dilution/Discharge Facilities falls within the scope of Class 3 Equipment, which is equivalent to the waste disposal facilities specified in the “Regulations on Technical Standards for Commercial Power Reactors and their Auxiliary Facilities”.

- The regulations for Class 3 Equipment specified in the “JSME S NC1-2012 Codes for Nuclear Power Generation Facilities - Rules on Design and Construction for Nuclear Power Plants (hereinafter referred to as “Design and Construction Rules”)” are applied to steel pipes containing ALPS treated water, and other domestic and overseas private standards, such as the Japan Industrial Standards (JIS), are also applied as necessary.
(Implementation Plan: II-2-50-6)

- Polyethylene pipes are considered to have structural strength if they conform to ISO or JWWA standards and are used within the application scope. The Pressure resistant hoses and expansion joints are considered to have structural strength if used at pressures and temperatures within the specifications set by the manufacturer.
(Implementation Plan: II-2-50-6)

2-1 (1)(v) Structure and strength of equipment, protection against natural phenomena such as earthquakes and tsunamis, etc.

1. Applicable standards (Assessment of structural strength)

“14. Design considerations (1) Applicable standards” (Handling of metal materials)

- The designing, selection of materials, manufacturing and inspections of structures, systems and components having safety functions shall comply with standards deemed appropriate to the importance of the safety functions they should perform.

- Assessment method (Implementation Plan: II-2-50-Attachment 3-5)
 - Check the minimum thickness of steel pipes to see that they satisfy the thickness required by the “Design and Construction Rules PPD-3411 (PPD-1.3)” (hereinafter (1)) or “Table PPD-3411-1 of the Design and Construction Rules PPD-3411(3)” (hereinafter (2)).
 - The required thickness of pipes must be set to the greater value of the following ((1) or (2)).
 - Pipe that receives pressure on the inside surface

Calculated pipe thickness required:
$$t = \frac{PD_0}{2S\eta + 0.8P} \cdot \cdot \cdot (i)$$

P : Maximum operating pressure (MPa)

D_0 : Pipe outer diameter (mm)

S : Maximum permissible tensile stress of the material at maximum operating temperature (MPa)

η : Efficiency of the longitudinal joint

- Minimum thickness required by the Design and Construction Rules for carbon steel pipes: $t_r \cdot \cdot \cdot (ii)$
-> Value determined from Table PPD-3411-1 of the Design and Construction Rules PPD-3411 (3)

2-1 (1)(v) Structure and strength of equipment, protection against natural phenomena such as earthquakes and tsunamis, etc.



1. Applicable standards (Assessment of structural strength)

“14. Design considerations (1) Applicable standards” (Handling of metal materials) (Continued)

- Assessment result (Implementation Plan: II-2-50-Attachment 3-5)
 - Table 1 shows the assessment result. Satisfying the required thickness, the pipes are considered to have sufficient structural strength.

Table-1 Structural strength assessment result of main pipes (Steel pipes)

Equipment assessed*	Outer diameter (mm)	Material	Maximum operating pressure (MPa)	Maximum operating temperature (°C)	Required thickness (mm)	Minimum thickness (mm)
Pipe (1)	216.3	SUS316LTP	0.49	40	0.46	5.68
Pipe (2)	139.8	SUS316LTP	0.98	40	0.59	4.37
Pipe (3)	165.2	SUS316LTP	0.98	40	0.69	4.37
Pipe (4)	216.3	SUS316LTP	0.98	40	0.91	5.68
Pipe (5)	165.2	SUS316LTP	0.49	40	0.35	4.37
Pipe (6)	114.3	SUS316LTP	0.49	40	0.24	3.50
Pipe (7)	76.3	SUS316LTP	0.98	40	0.32	3.00
Pipe (8)	114.3	SUS316LTP	0.98	40	0.48	3.50
Pipe (9)	114.3	STPG370	0.98	40	3.40	5.25
Pipe (10)	914.4	STPY400	0.60	40	4.56	11.43
Pipe (11)	2235.2	SM400B	0.60	40	11.14	15.00
Pipe (12)	1828.8	SM400B	0.60	40	9.11	12.00

*: See the reference document for the pipe numbers.

“14. Design considerations (1) Applicable standards” (Handling of non-metal materials not specified in JSME)

- The designing, selection of materials, manufacturing and inspections of structures, systems and components having safety functions shall comply with standards deemed appropriate to the importance of the safety functions they should perform.

- Polyethylene pipes are considered to have structural strength if they conform to ISO or JWWA standards and are used within the application scope. The Pressure resistant hoses and expansion joints are considered to have structural strength if used at pressures and temperatures within the specifications set by the manufacturer.

(Implementation Plan: II-2-50-6)

Applicability of non-metal pipes*

		Maximum operating pressure (MPa)	Maximum operating temperature (°C)
Polyethylene pipe		1.00	40
Pressure resistant hose		0.75	60
Expansion joint	Circulating pipe Transfer pipe	1.00	80
	Seawater pipe	0.60	40

*: Values for some equipment are subject to change because they are still under detailed design, equipment that meets the maximum operating pressure and temperature of the system must be adopted.

2-1 (1)(v) Structure and strength of equipment, protection against natural phenomena such as earthquakes and tsunamis, etc.

2. Seismic importance category and equipment class

- The earthquake-proof categories and equipment class of equipment comprising the ALPS Treated Water Dilution/Discharge Facilities are as follows.
 - Rationale for the selection of seismic importance category
Judging from the result of the radiation effects assessment and the study of functional measures, it is appropriate to classify them into “Class C” of the seismic categories.
 - Rationale for the selection of equipment class
They are considered to be equivalent to the “Class 3 containers” or “Class 3 pipes” defined in Article 2, Paragraph 2, Item 34 of the “Regulations on Technical Standards for Commercial Power Reactors and their Auxiliary Facilities”.

Facilities	Equipment		Seismic importance category	Equipment class
Measurement/ confirmation facilities	Measurement/Confirmation tanks		C	Class 3
	Circulating pipe		C	Class 3
	Circulation pump		C	-*
Transfer Facility	Transfer pipe		C	Class 3
	ALPS Treated Water transfer pump		C	-*
Dilution Facility	Seawater pipe	Contains ALPS treated water	C	Class 3
		Contains only seawater	C	-
	Seawater transfer pump			C

*: In line with the “Guidelines for the Procedures for the Construction and Planning of Nuclear Power Reactor Facilities”, the strength of pumps to be connected to Class 3 equipment must be calculated based on the “Design and Construction Rules” or JIS.

2-1 (1)(v) Structure and strength of equipment, protection against natural phenomena such as earthquakes and tsunamis, etc.

3. Design considerations for natural phenomena (Earthquakes)

“14. Design considerations (2) Design considerations for natural phenomena” (Earthquakes)

- Structures, systems, and components having safety functions shall be classified in terms of Earthquake-proof Design in consideration of the importance of their safety functions and the impacts on the safety the loss of their function might have in the event of an earthquake, and shall be designed to sufficiently withstand the design seismic load that is considered to be appropriate.

“14. Design considerations (2) Design considerations for natural phenomena” (Earthquakes) (Continued)

3. Safety-based earthquake-proof categories at 1F and seismic motion to be applied

(1) earthquake-proof categories

For the current 1F, instead of the earthquake-proof categories for general commercial nuclear power reactors, it is considered to be appropriate to apply the following categories according to the level of radiological impact on the public that might be caused when a loss of functions of facilities occurs^{*5}. They were set while referring to the earthquake-proof categories for fuel processing and utilizing facilities that handle unsealed nuclear fuel and materials. Furthermore, in consideration of the current situation of 1F, facilities that fall within the scope of any of the following three in Class B should be classified as Class B+, a class requiring higher earthquake resistance.

Class S: $5 \text{ mSv} < \text{Public dose around the site}$

Class B+: $50 \text{ } \mu\text{Sv} < \text{Public dose around the site} \leq 5 \text{ mSv}$

- Facilities for permanent use
- Facilities that significantly impact exposure doses of persons engaging in risk reduction activities and radiation work when the seismic resistance function is lost.
- Facilities that may have a ripple effect on Class S facilities^{*6}

Class B: $50 \text{ } \mu\text{Sv} < \text{Public dose around the site} \leq 5 \text{ mSv}$

Class S: $\text{Public dose around the site} \leq 50 \text{ } \mu\text{Sv}$

*5: When it is difficult to prove the validity of an impact assessment due to the discharge of liquid radioactive materials performed to determine the seismic category, the equipment must be exempt from the impact assessment. If the equipment contains liquid that has significant external impacts when discharged, such as liquid before the treatment with ALPS, it must be designed so as not to cause leakage into the ocean even when it loses its function. As for facilities containing a liquid that has relatively minor external impacts when discharged, such as liquid treated with ALPS, although it is desirable to take the same measures as those mentioned above, if it is difficult to do so, measures to mitigate the impact in the event of a discharge caused when functions of the facilities are lost, such as swift initial response such as temporary hoses, must be taken.

*6: Since the accident, facilities that have ripple effects on reactor containment and spent fuel pools, which are Class S facilities, have been required to withstand the seismic motion applied to Class B facilities and Ss 600. However, the current 1F is different from general nuclear power reactor facilities, and the potential radiation risks are becoming low as radionuclides in spent fuel and debris are decaying. Therefore, judging from the level of external impacts that should be taken into account, facilities that have ripple impacts on Class S facilities, such as fuel removal facilities are classified as Class B+.

2-1 (1)(v) Structure and strength of equipment, protection against natural phenomena such as earthquakes and tsunamis, etc.

3. Design considerations for natural phenomena (Earthquakes)

“14. Design considerations (2) Design considerations for natural phenomena” (Earthquakes) (Continued)

- In response to the announcement of the “Earthquake-proof Design Concept” by the Nuclear Regulation Authority (July 7, 2021), equipment is reclassified based on the “level of radiological impact assumed to occur when a loss of functions of the facilities occurs” while referring to the earthquake-proof categories classification method for nuclear fuel facilities.
- Judging from the result of the radiation effects assessment and the study of functional measures, it seems to be appropriate to classify the facilities into “Class C” of the seismic categories.

[Possible loss of functions of facilities]

- Connecting pipes, etc., are damaged when Measurement/Confirmation tanks slide in the event of an earthquake. ALPS Treated Water leaks from the damaged part.
- Result of the radiological impact on the public due to loss of the functions of Measurement/Confirmation tanks: < 1 μSv/year
Result of the radiological impact on the public due to the transfer of leaked water into the air: 0.4 μSv

[Agile response, etc.]

- In the event of an earthquake with a seismic intensity of 5 or higher, the site of tanks with connecting valves open must be checked first, and if leakage is confirmed, close the connection valve immediately.
- To prevent significant leaks of the water stored in tanks with the earthquake-proof categories of Class C in the event of damage to them, etc., due to an earthquake, foundation weirs must be installed around them. Being classified as Class B of the seismic categories, the weirs must have the strength to withstand the horizontal design seismic coefficient required for Class B structures.
- If the stored water leaks and accumulates in a foundation weir, the water must be collected with temporary pumps, a high-pressure suction vehicle, etc. The collected water must be discharged in a sound tank or building.

2-1 (1)(v) Structure and strength of equipment, protection against natural phenomena such as earthquakes and tsunamis, etc.

3. Design considerations for natural phenomena (Earthquakes)

[Severity of radiological impact on the public]

- The results of the radiation impact assessment on the public due to the loss of the function of the Measurement/Confirmation tanks※ are as follows.

※The assessment here includes the five multinuclides treated water storage tanks in Chapter 2.5

➤ Conditions

Radiation impacts on the public in the event that striking earthquakes. An Earthquake arise damages on connecting pipes and like that following sliding of the tanks. From the damaged points all ALPS Treated Water contained in the tanks leaks outside of the tanks (For the impact assessment, assumed assessment modeled as a single large cylinder shape with the same volume and height as the tank group).

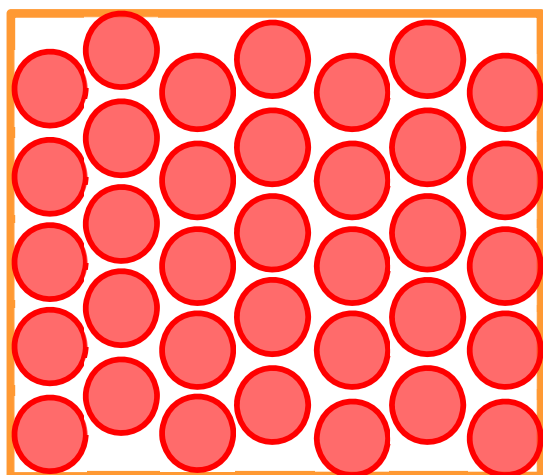

$$1,000 \text{ m}^3 \times 35 \text{ units} = 35,000 \text{ m}^3$$

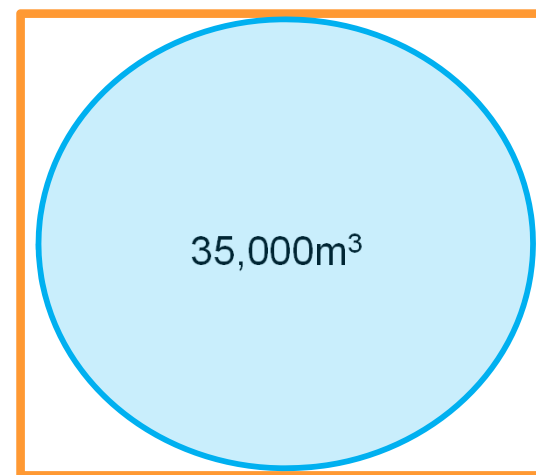

35,000m³

Exposure assessment by direct and sky-shine radiations: <1 μSv/year (Nearest assessment point: No. 70)

※ As an approximation, it is assumed that the impact on the site boundary would increase by about 1.25 to 2.0 times if the tanks are no longer shielded. Even if a conservative calculation of 2.0 times is made, the impact on the nearest point is insignificant.

2-1 (1)(v) Structure and strength of equipment, protection against natural phenomena such as earthquakes and tsunamis, etc.

[Supplement] Assessment of direct and skyshine rays from K4 area tanks

- Impact assessment of the direct and skyshine rays on the site boundary at the K4 area tank*.

(Implementation Plan: 2.5, Att 12, Att-7)

*: Approved on July 4, 2015

➤ Conditions

For the impact assessment on the site boundary, the assessment framework is a schematic assessment modeled as a single large cylinder shape with the same volume and height as the tank group.

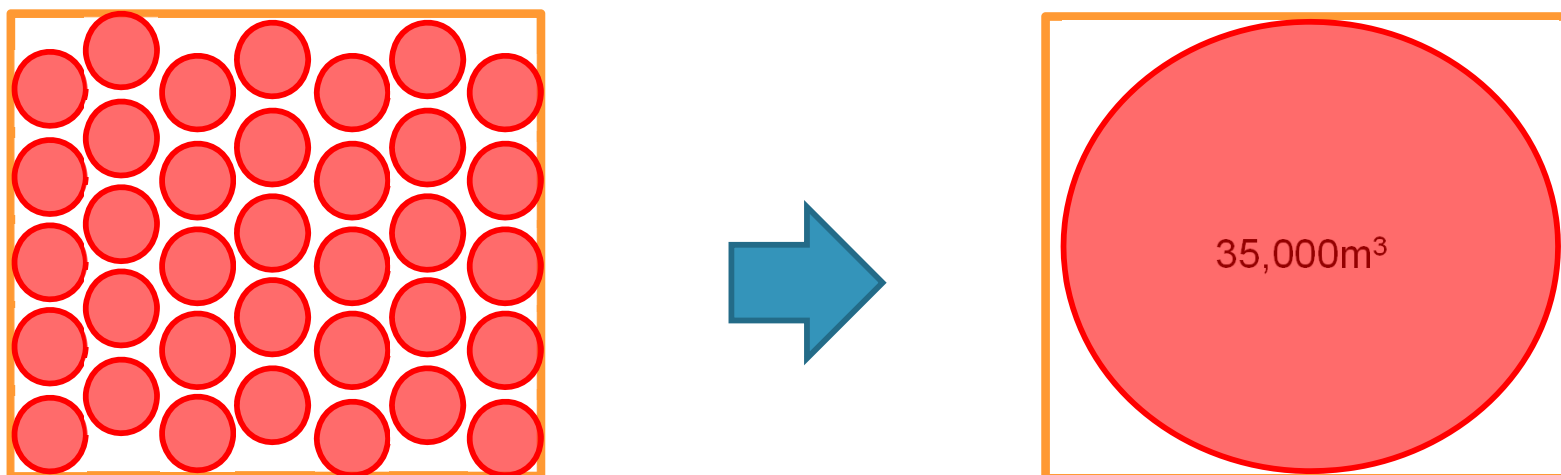

$$1,000 \text{ m}^3 \times 35 \text{ units} = 35,000 \text{ m}^3$$

Exposure evaluation by direct and skyshine rays: Less than 0.0001 mSv/year (Nearest assessment point: No.70)
(1.9 E - 03 μSv/year)

3. Design considerations for natural phenomena (Earthquakes)

[Severity of radiological impact on the public]

- The results of the radiation impact assessment on the public due to the loss of the function of the Measurement/Confirmation tanks※ are as follows.

*1: The assessment here includes Chapter 2.5 Five ALPS Treated Water tanks.

➤ Conditions

An Earthquake arise damages on connecting pipes and like that following sliding of the tanks. From the damaged points ALPS Treated Water leaks, and spreads over the entire storable area in the tank weir the evaporate and disperse the water containing tritium. Internal exposure from tritium ingested by people living at the site boundary (the nearest assessment point) through their breathing.

(Assumed radiation impacts in case of collecting water within※² two weeks)

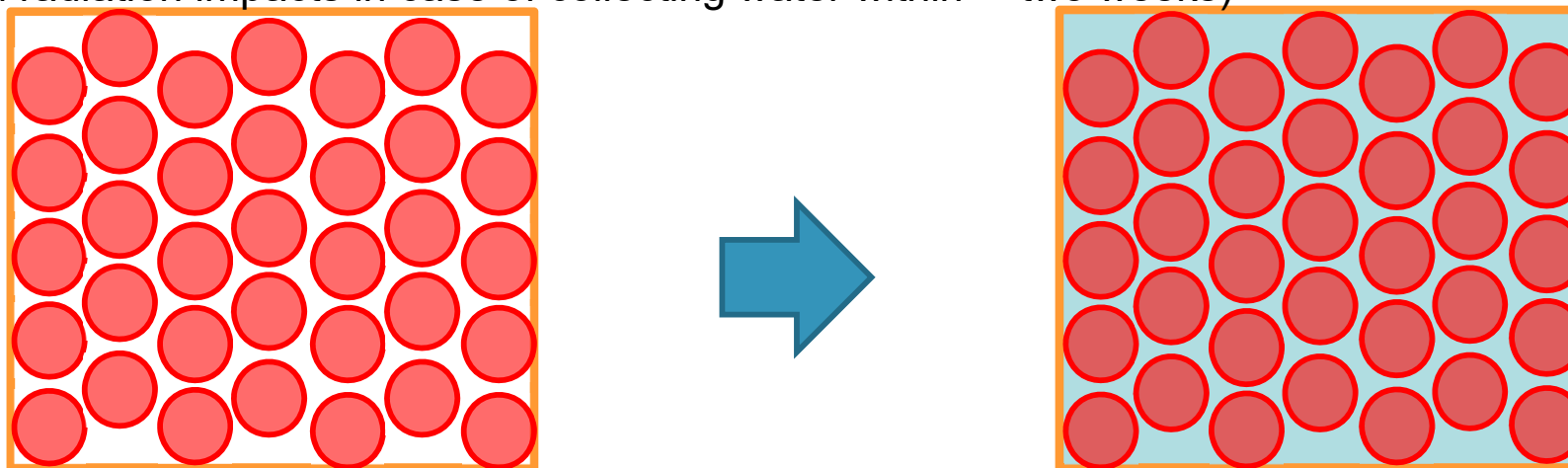

Tank area where water can be stored (2,201 m²)

Exposure Evaluation by airborne migration: $0.4\mu\text{Sv}$ (Nearest evaluation point: No. 70)

※²: If a 30m³ /h temporary pump is used for 24 hours collection, it would take about three days. Taking into account the preparation work, it is estimated to take about one week, but it was set to be two weeks conservatively.

2-1 (1)(v) Structure and strength of equipment, protection against natural phenomena such as earthquakes and tsunamis, etc.

[Supplement] Impact assessment due to loss of system functions down-stream from the Measurement/Confirmation tanks (1/2)

- Radiation effects assessment in case of loss of functions in the area of down-stream from the Measurement/Confirmation tanks were assessed as follows.

➤ Conditions

In the equipment that placed in the area of down-stream from the Measurement/Confirmation tanks, one or more outdoor transfer pipes containing largest amount of ALPS Treated Water are damaged by an earthquake. Put the case that all the water across the pipes, from the outlet of the treated water transfer pump to the inlet of the emergency isolation valve-1, leaks out.

Furthermore, according to the operating rules, when an earthquake with a seismic intensity of 5 or larger occurs, the discharge into the sea must be suspended, and the electric-powered valve at the outlet of the Measurement/Confirmation tanks must be closed. Therefore, this assumption was taken into account for this effects assessment.

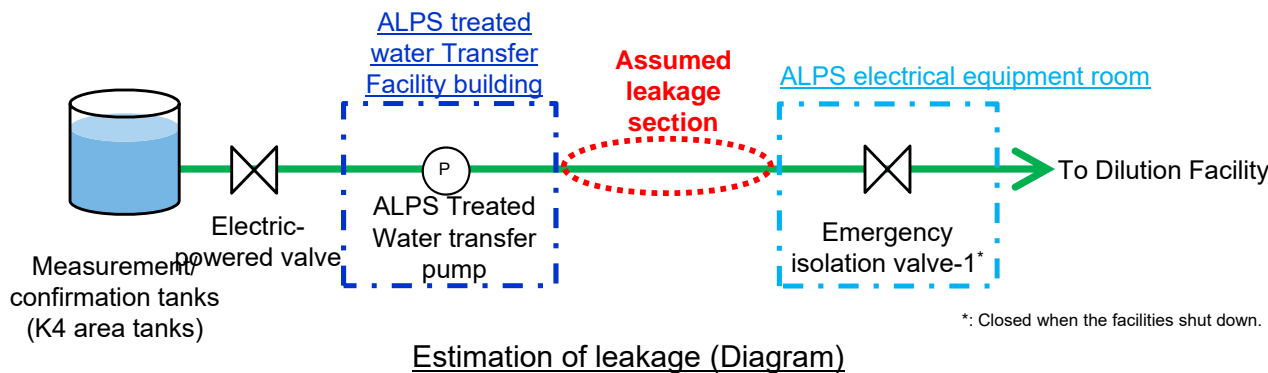

Estimation of leakage (Diagram)

< Piping overview >

Diameter	100A
Length	Approx. 1 km

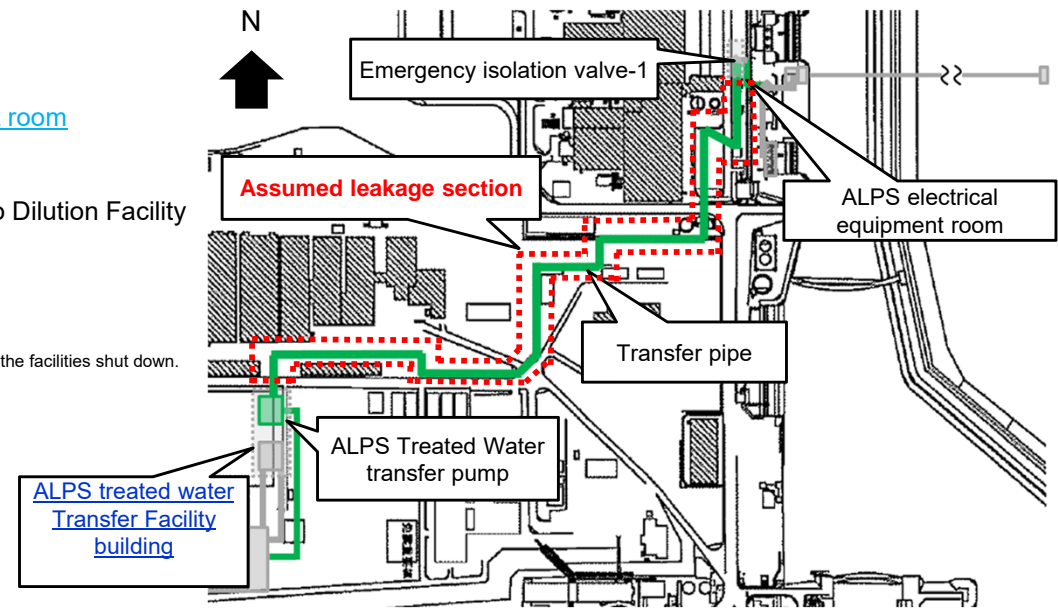

Estimation of leakage (Overview of the entire system)

- The maximum amount of leakage from equipment down-stream from the Measurement/Confirmation tanks is approximately 8 m³, which is much smaller than the amount estimated for leakage from the Measurement/Confirmation tanks. Therefore, the radiological impact on the public due to the loss of the functions of the ALPS Treated Water Dilution/Discharge Facilities can be represented by the exposure dose estimated for leakage from the Measurement/Confirmation tanks.

[Agile response, etc.]

- When an earthquake with a seismic intensity of 5 or larger occurs, the discharge into the sea must be suspended, the electric-powered valve at the outlet of the Measurement/Confirmation tanks must be closed, and check the leakage through the tank water levels (Re-post). In addition, after the earthquake, check occurrence of abnormalities in the facilities through an intense patrol with inspections on all outdoor facilities, including transfer pipes.
- The connections of polyethylene pipes of the transfer pipes laid outdoors must be welded to prevent leakage. Furthermore, the seismic resistance of polyethylene pipes will be ensured by the flexibility of the material.
- ⇒ No damage to polyethylene pipes installed on the Fukushima Daiichi NPS site has been confirmed at the time of the earthquake that occurred off the coast of Fukushima Prefecture on February 13, 2021.
- At locations where there is a roadway running by transfer pipes, fences, etc., must be installed to protect the pipes from damage due to external factors.
- Transfer pipes must be separated from drainage channels as far as possible, pipes crossing drainage channels must be laid in boxed steel, and sandbags must be set to ensure water leaked from the end of the boxed steel will not directly flow into the drainage.

2-1 (1)(v) Structure and strength of equipment, protection against natural phenomena such as earthquakes and tsunamis, etc.

3. Design considerations for natural phenomena (Natural phenomena other than earthquakes)

"14. Design Considerations ② Design Considerations for Natural Phenomena" (Non-Earthquake Natural Phenomena)

- Buildings, systems and devices with safety functions shall be designed so that the safety of the facilities will not be impaired by expected natural phenomena other than earthquakes (tsunamis, heavy rainfall, typhoons, tornadoes, etc.). Buildings, systems and facilities with a particularly high level of importance of safety functions shall be designed in consideration of the conditions that are considered to be the most severe of the expected natural phenomena, or the case where the accident load is appropriately combined with the natural force.

■ Tsunami (Implementation Plan: II-2-50-5)

- Some equipment installed in the Measurement/Confirmation Facilities and Transfer Facility of the ALPS Treated Water Dilution/Discharge Facilities, excluding the Dilution Facility, should be constructed on the ground at about 33.5m Tokyo Peil (T.P. or Tokyo Bay mean tidal level) or higher where a tsunami is expected to out of reach.
- In addition, when issuing a large tsunami warning, Both of Transfer and Dilution Facilities will be stopped to avoid the damage risk caused by tsunami.

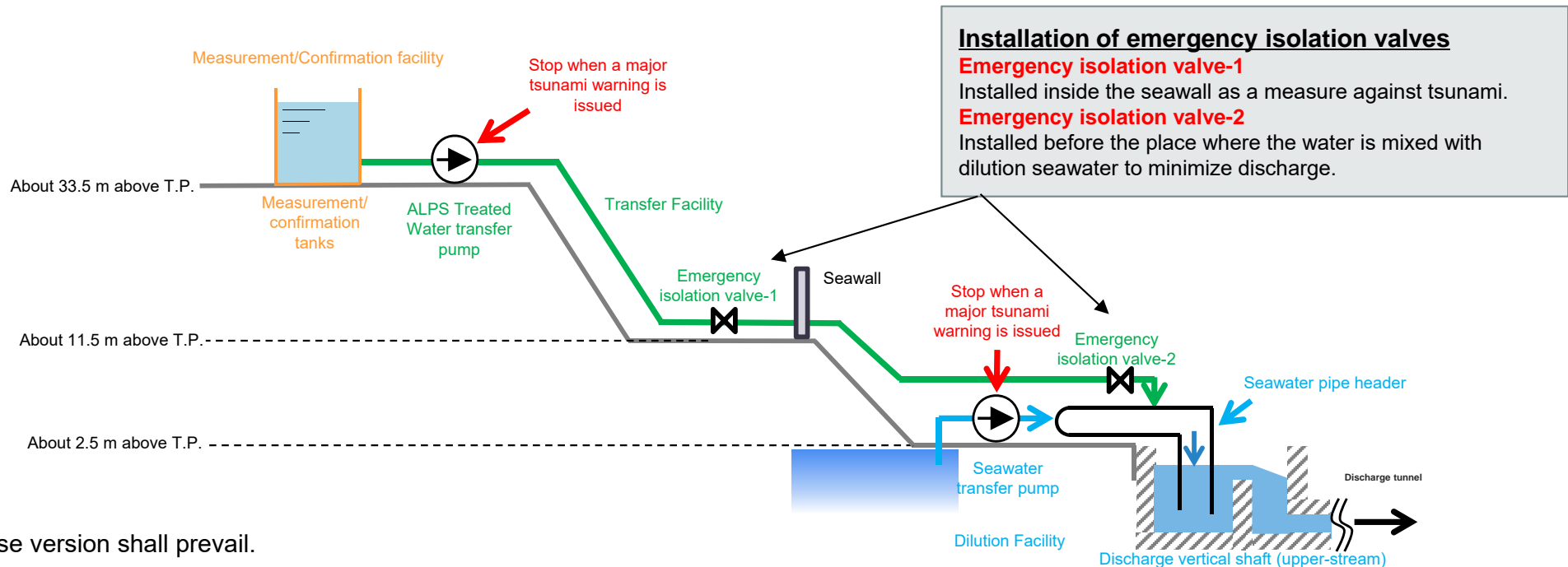

2-1 (1)(v) Structure and strength of equipment, protection against natural phenomena such as earthquakes and tsunamis, etc.

Excerpt from document 1-2 for the 93rd Review Meeting on Monitoring and Evaluation of the Specified Nuclear Facility (the Title Changed + Some Sentences Revised)



[Supplement] Positional relationship between equipment/facilities and the seawalls

- According to the impact analysis caused by Japan Trench Tsunami, the flooding depth assumed on the T.P. (Tokyo Bay Mean Tidal Kevel) +2.5 m ground is 9 m or more, which means seawater pumps and some other equipment are highly likely under water.
- On the other hand, the emergency isolation valve-1 and the ALPS Treated Water transfer line are not assumed to be inundated because the valve is on the T.P. +11.5 m ground and surrounded by the seawalls, the transfer line is planned to be laid at the height of about 0.3 to 0.4 m above the ground, and the maximum flooding depth is less than 0.2 m at any place.

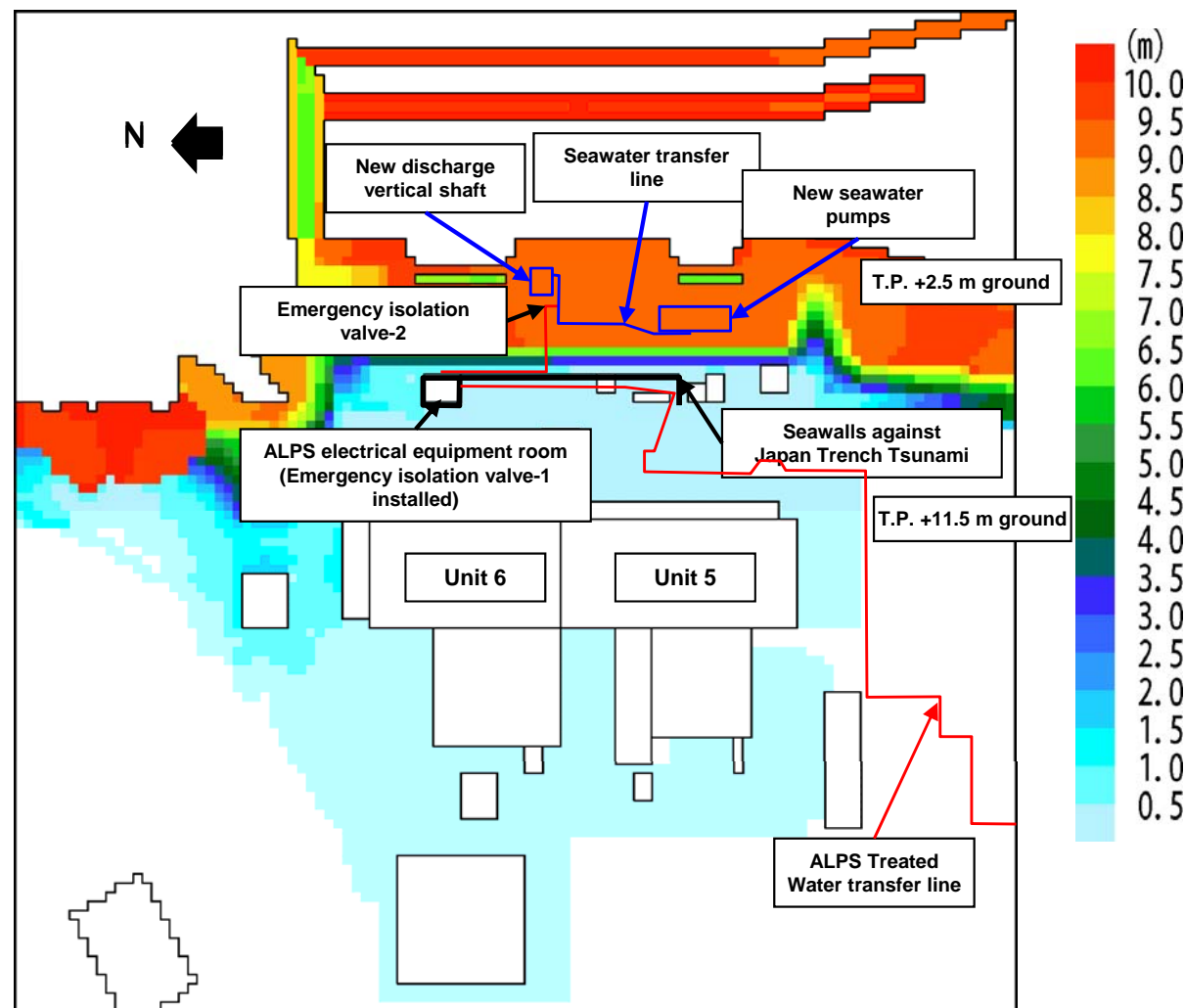
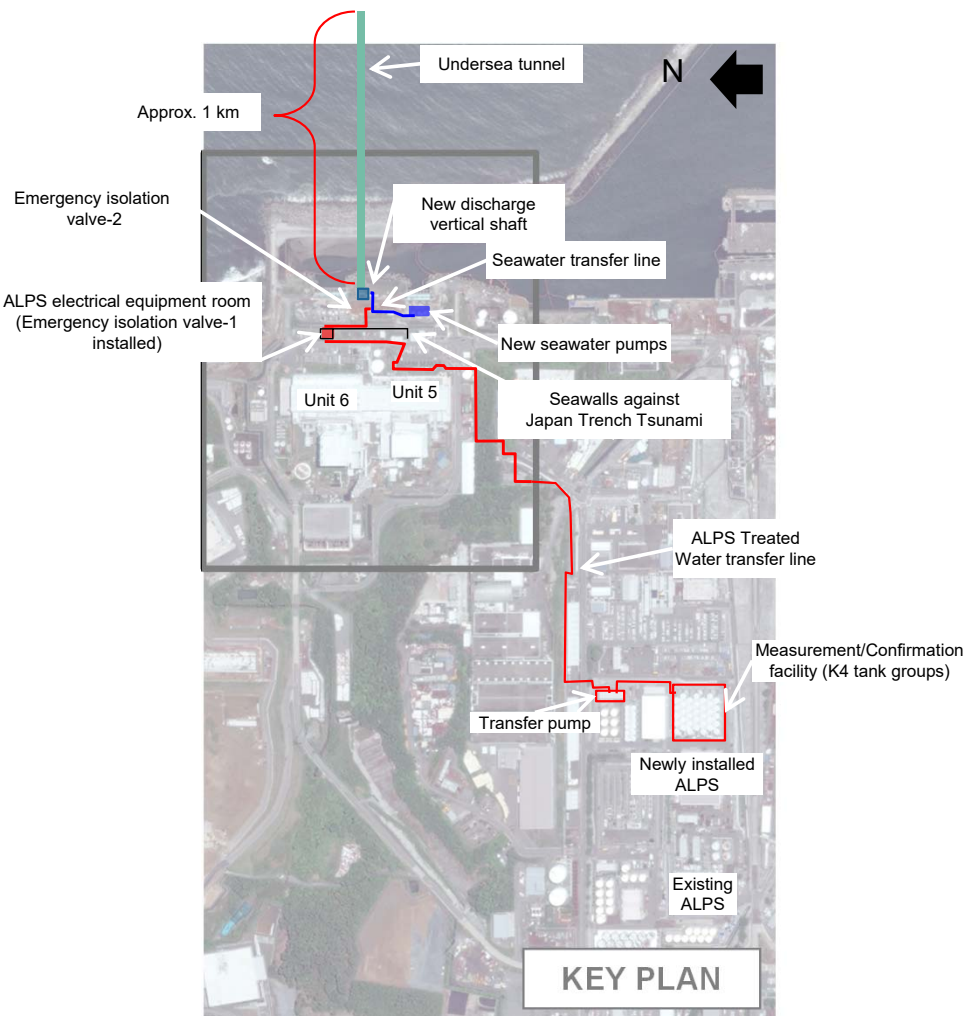

Distribution of maximum flooding depth caused by Japan Trench Tsunami
(Analysis results under the same conditions as in the 83rd Commission on Supervision and Evaluation of the Specified Nuclear Facility)

2-1 (1)(v) Structure and strength of equipment, protection against natural phenomena such as earthquakes and tsunamis, etc.

3. Design considerations for natural phenomena (Natural phenomena other than earthquakes)

**“14. Design considerations (2) Design considerations for natural phenomena” (Natural phenomena other than earthquakes)
(Continued)**

- Snow accumulation (Implementation Plan: II-2-50-5)
 - In order to protect facilities from damage caused by accumulated snow, buildings shall be designed to withstand the snow load designated by the Regulations for Enforcement of Building Standard Law and Detailed Rules for Enforcement of Fukushima Prefectural Building Standard Law.
- Lightning strike (Implementation Plan: II-2-50-5)
 - Active components and electrical systems must be grounded to protect them from damage when struck by lightning.
- Tornadoes (Implementation Plan: II-2-50-5)
 - When the occurrence of tornadoes is predicted, the systems must be shut down in view of the risk of system damage due to tornadoes.
- Typhoon (strong wind) (Implementation Plan: II-2-50-5)
 - Circulation pumps and ALPS Treated Water transfer pumps of the ALPS Treated Water Dilution/Discharge Facilities shall be installed in the steel-framed ALPS treated water Transfer Facility building where facilities are unlikely to be damaged by a typhoon (strong wind). In addition, mechanical components of outdoor transfer pipes, etc., shall be designed to be fixed with foundation bolts, etc., to prevent them from falling over.
 - Electronic components, such as control panels, of the ALPS Treated Water Dilution/Discharge Facilities shall be installed in the lightweight steel-framed ALPS electrical equipment room where equipment is unlikely to be damaged by a typhoon (strong wind).

In addition, when a tsunami advisory, tornado advisory, etc., are issued and there is a risk of damage to the facilities or deviation from the designed discharge into the sea, the facilities must be stopped.

The following slides are for reference.

[Reference] Basic specifications of equipment and facilities (ALPS Treated Water dilution/ Discharge Facility)

■ Circulation pump

Number of units	2 units
Capacity	160 m ³ /h per unit

■ ALPS Treated Water transfer pump

Number of units	2 units
Capacity	30 m ³ /h per unit

■ Seawater transfer pump

Number of units	3 units
Capacity	7,086 m ³ /h per unit

■ Discharge guide

Number of units	1 unit
Main dimensions	Length 2,100 mm x Width 2,100 mm x Height 7,096 mm (upper-stream) Length 2,140 mm x Width 2,140 mm x Height 11,144 mm (down-stream)
Material	SUS316L

■ Discharge vertical shaft (upper-stream storage)

Number of units	1 unit
Structure	Reinforced concrete

[Reference] Basic Pipe Specifications (ALPS Treated Water Dilution/Discharge Facilities)

Name	Specifications	
From the outlet of the measurement/confirmation tanks to the inlet of the Circulation pumps (Steel pipe)	Nominal diameter / Thickness Material Maximum operating pressure Maximum operating temperature	200A/Sch.20S SUS316LTP 0.49MPa 40°C
(Polyethylene pipe)	Nominal diameter Material Maximum operating pressure Maximum operating temperature	Equivalent to 200A Polyethylene 0.49MPa 40°C
(Pressure resistant hose)	Nominal diameter Material Maximum operating pressure Maximum operating temperature	Equivalent to 200A Synthetic rubber 0.49MPa 40°C
(Expansion joint)	Nominal diameter Material Maximum operating pressure Maximum operating temperature	Equivalent to 200A Synthetic rubber 0.49MPa 40°C
From the outlet of the Circulation pumps to the inlet of the measurement/confirmation tanks (Steel pipe)	Nominal diameter / Thickness Material Maximum operating pressure Maximum operating temperature	125A/Sch.20S 150A/Sch.20S 200A/Sch.20S SUS316LTP 0.98MPa 40°C
(Polyethylene pipe)	Nominal diameter Material Maximum operating pressure Maximum operating temperature	Equivalent to 150A Polyethylene 0.98MPa 40°C
(Expansion joint)	Nominal diameter Material Maximum operating pressure Maximum operating temperature	Equivalent to 125A Synthetic rubber 0.98MPa 40°C

Name	Specifications	
Between measurement/confirmation tanks (Steel pipe)	Nominal diameter / Thickness Material Maximum operating pressure Maximum operating temperature	200A/Sch.20S SUS316LTP 0.49MPa 40°C
(Polyethylene pipe)	Nominal diameter Material Maximum operating pressure Maximum operating temperature	Equivalent to 200A Polyethylene 0.49MPa 40°C
(Pressure hose)	Nominal diameter Material Maximum operating pressure Maximum operating temperature	Equivalent to 200A Synthetic rubber 0.49MPa 40°C
From the outlet of the Measurement/Confirmation tanks to the inlet of the ALPS Treated Water transfer pump (Steel pipe)	Nominal diameter / Thickness Material Maximum operating pressure Maximum operating temperature	100A/Sch.20S 150A/Sch.20S SUS316LTP 0.49MPa 40°C
(Polyethylene pipe)	Nominal diameter Material Maximum operating pressure Maximum operating temperature	Equivalent to 100A Equivalent to 150A Polyethylene 0.49MPa 40°C
(Expansion joint)	Nominal diameter Material Maximum operating pressure Maximum operating temperature	Equivalent to 100A Synthetic rubber 0.49MPa 40°C

[Reference] Basic Pipe Specifications (ALPS Treated Water Dilution/Discharge Facilities)

Name	Specifications	
From the outlet of the ALPS Treated Water transfer pump to the inlet connection of the seawater pipe header (Steel pipe)	Nominal diameter / Thickness Material Maximum operating pressure Maximum operating temperature	100A/Sch.40 STPG370 0.98MPa 40°C
(Steel pipe)	Nominal diameter / Thickness Material Maximum operating pressure Maximum operating temperature	65A/Sch.20S 100A/Sch.20S 150A/Sch.20S SUS316LTP 0.98MPa 40°C
(Polyethylene pipe)	Nominal diameter Material Maximum operating pressure Maximum operating temperature	Equivalent to 100A Polyethylene 0.98MPa 40°C
(Expansion joint)	Nominal diameter Material Maximum operating pressure Maximum operating temperature	Equivalent to 65A Equivalent to 100A Synthetic rubber 0.98MPa 40°C

Name	Specifications	
From the outlet of the seawater transfer pumps to the inlet of the seawater pipe header (Steel pipe)	Nominal diameter / Thickness Material Maximum operating pressure Maximum operating temperature	800A/12.7mm 900A/12.7mm STPY400 0.60MPa 40°C
(Steel pipe)	Nominal diameter / Thickness Material Maximum operating pressure Maximum operating temperature	900A/Sch.20S SUS329J4LTP 0.60MPa 40°C
(Expansion joint)	Nominal diameter Material Maximum operating pressure Maximum operating temperature	Equivalent to 800A Equivalent to 900A Synthetic rubber 0.60MPa 40°C
Seawater pipe header (Steel pipe)	Nominal diameter / Thickness Material Maximum operating pressure Maximum operating temperature	1800A/13mm 2200A/16mm SM400B 0.60MPa 40°C
From the outlet of the seawater pipe header to the discharge guide (Steel pipe)	Nominal diameter / Thickness Material Maximum operating pressure Maximum operating temperature	1800A/13mm SM400B 0.60MPa 40°C
(Expansion joint)	Nominal diameter Material Maximum operating pressure Maximum operating temperature	Equivalent to 1800A Synthetic rubber 0.60MPa 40°C

[Reference] Basic Specifications of Measurement/Confirmation Tanks

- Measurement/Confirmation tanks (using K4 tanks)

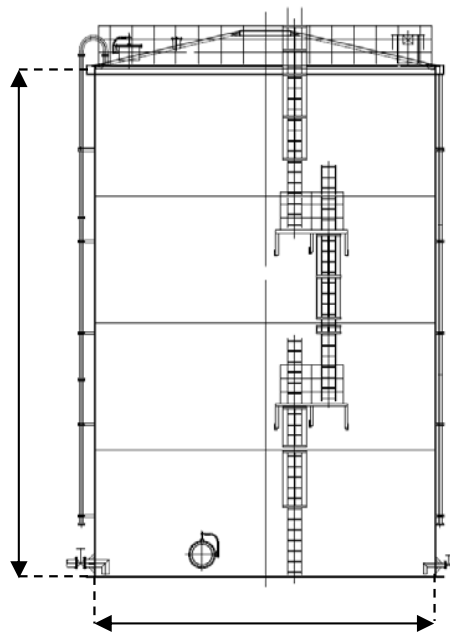
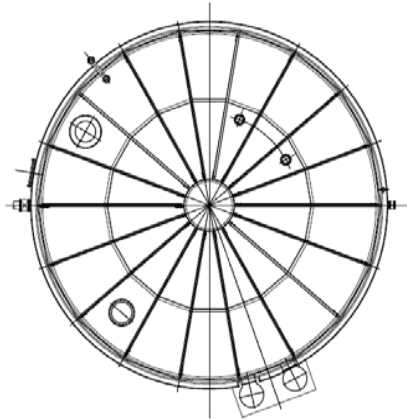

Height: 14,565 mm

Tank capacity		m ³	1,000
Main dimensions	Inner diameter	mm	10,000
	Thickness of shell plate	mm	15
	Thickness of bottom plate	mm	25
	Height	mm	14,565
Thickness of pipe stand	100A	mm	8.6
	200A	mm	12.7
	600A	mm	16.0
Material	Shell plate/Bottom plate	-	SS400
	Pipe stand	-	STPT410,SS400

➤ Design temperature 50°C

[Reference] Specifications of facilities related to Measurement/Confirmation tanks

- Tank weir* (Foundation weirs are installed to prevent leakage from spreading) (Implementation Plan: II-2-5- Attachment 12-25)

The capacity in the foundation weirs must be equal to the sum of the capacity of 1 tank per 20 tanks (When the number of tanks is 20 units or more, the capacity of 1 tank per 20 tanks, and even when the number is less than 20, the capacity to retain water equal to the capacity of 1 tank can be secured) and the volume of water that can be retained in the allowance guaranteed in view of operations at the time of heavy rain (about 20 cm high of the weirs).

*For tank weirs, those in the K4 area will be used.

Place of installation	Number of installed tanks	Assumed leakage		Capacity inside the foundation weirs around tanks (m ³)	(Planned value)			
		Number of units	Capacity (m ³)		Area in the foundation weirs around tanks (m ²)	Area exclusively used for the tanks (m ²)	Area that can retain water (m ²)	Height of foundation weirs around tanks (m)
K4	35	1.75	1,750	2,190 or more	5,145	2,944	2,201	0.995 or more

- Pipe attached to the Measurement/Confirmation tanks

	Nominal diameter	Material	Maximum operating pressure	Maximum operating temperature
Connecting pipe (Pressure resistant hose)	Equivalent to 200A	EPDM synthetic rubber	1.0MPa	50°C
Inlet pipe (steel pipe)	100A	STPT410	1.0MPa	50°C

- Valves attached to Measurement/Confirmation tanks

	Nominal diameter	Material	Maximum operating pressure	Maximum operating temperature
Connecting valve	Equivalent to 200A	FCD450-10	1.0MPa	50°C

- Measurement/Confirmation tank water gauge

Detection method	TEPCO's management precision
Microwave type	± 1%

- Agitation equipment

Number of units
30 units

[Reference] Pipe Sections of ALPS Treated Water Dilution/Discharge Facilities for the Strength Assessment

- The points to be assessed are as follows:

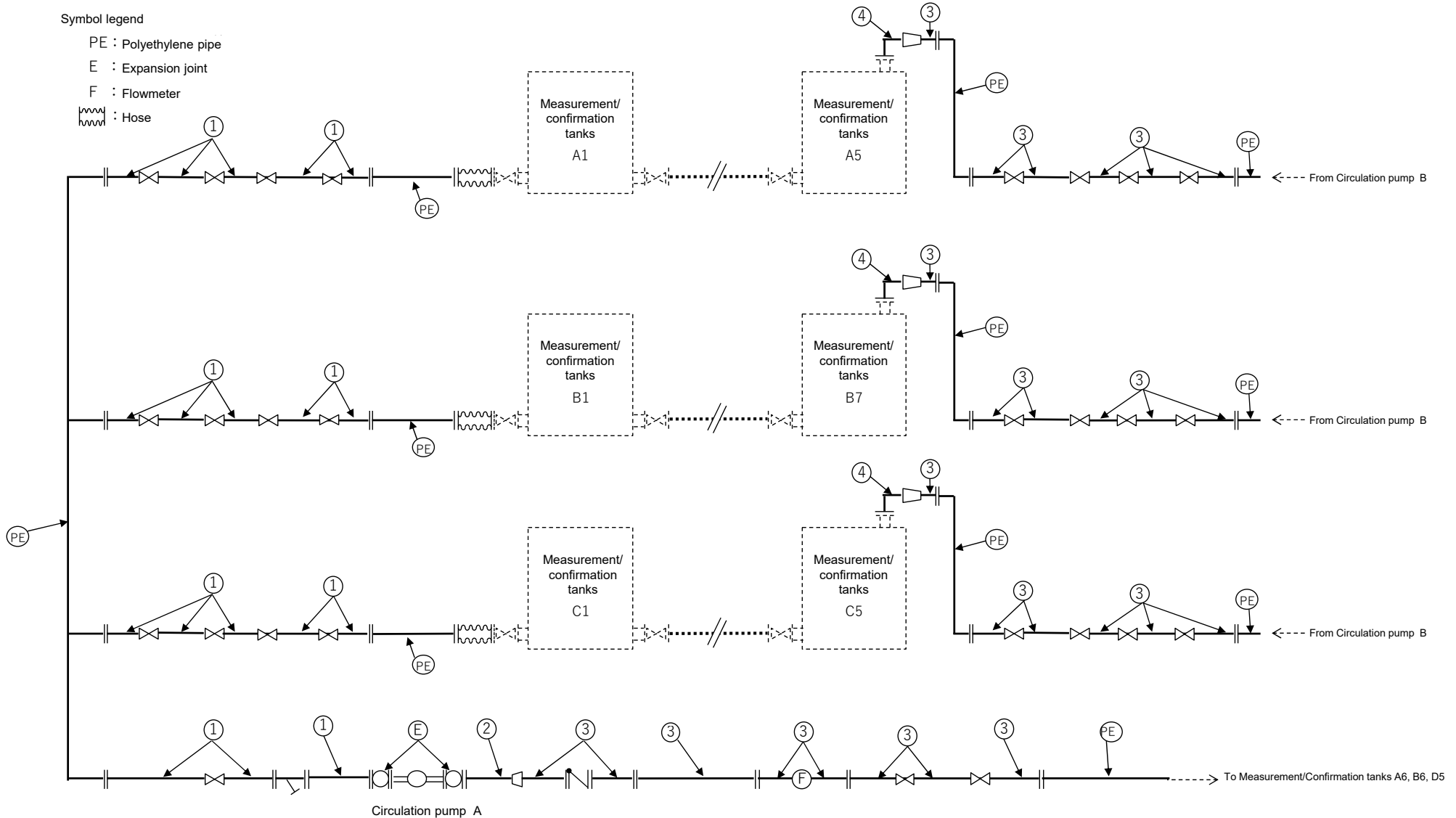

Fig. 1 Pipe diagram (1/5)

[Reference] Pipe Sections of ALPS Treated Water Dilution/Discharge Facilities for the Strength Assessment

Excerpt from document 1-1, the 3rd Review Meeting on the Implementation Plan Regarding the Handling of ALPS Treated Water



- The points to be assessed are as follows:

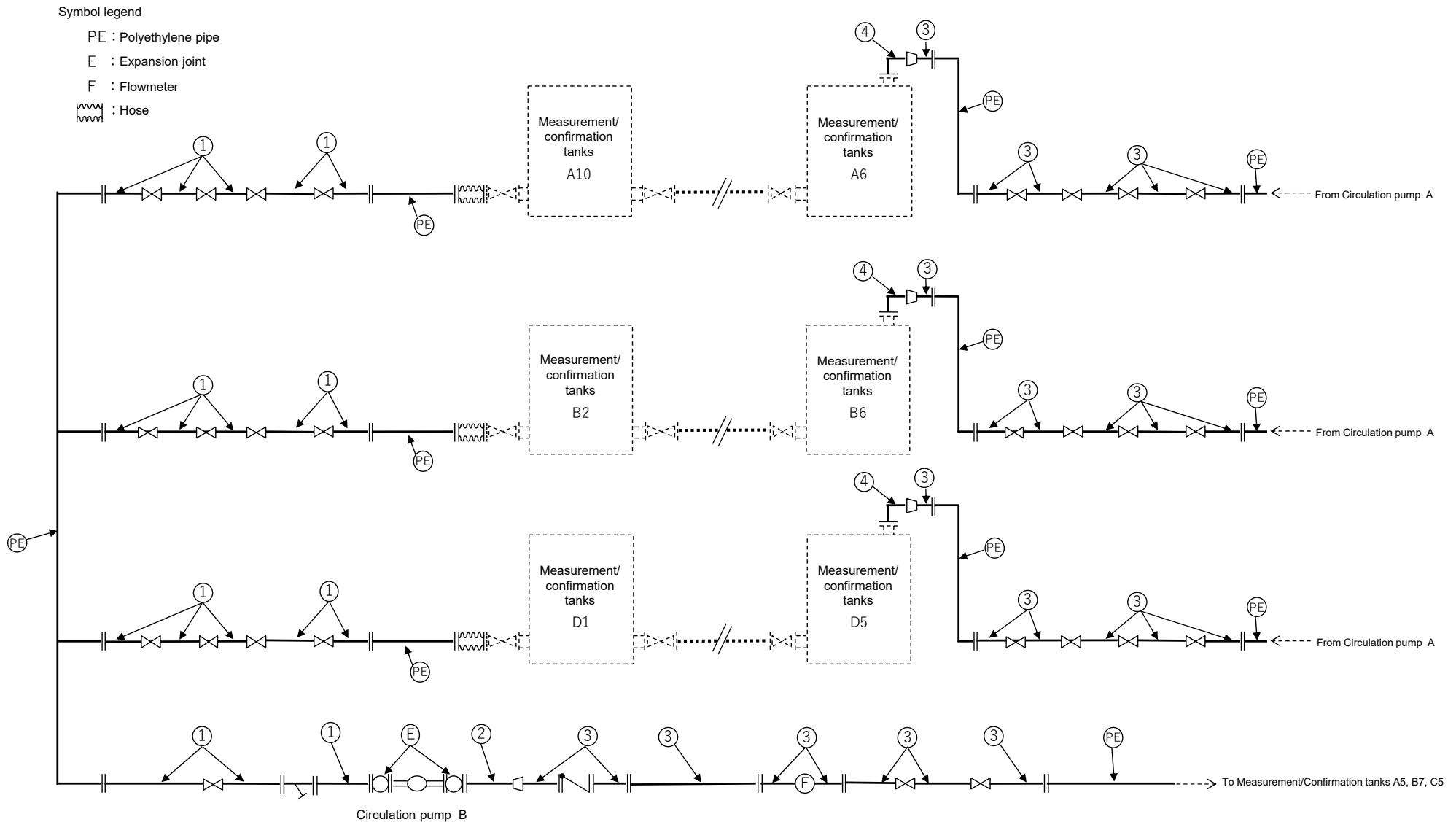
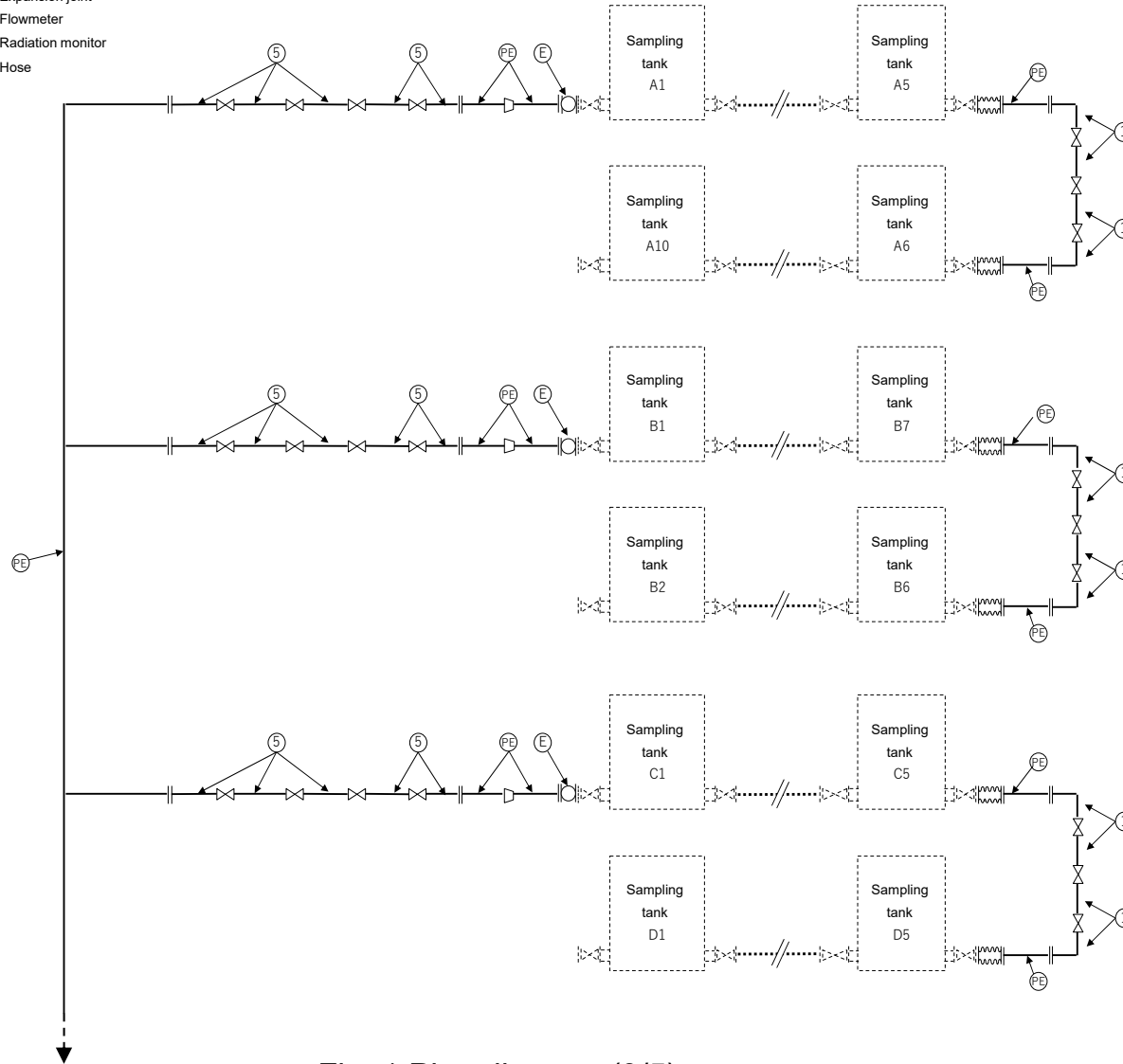

Fig. 1 Pipe diagram (2/5)

- The points to be assessed are as follows:

Symbol legend

- PE : Polyethylene pipe
- E : Expansion joint
- F : Flowmeter
- R : Radiation monitor
- ~~~~~: Hose



To ALPS Treated Water transfer pump

Fig. 1 Pipe diagram (3/5)

[Reference] Pipe Sections of ALPS Treated Water Dilution/Discharge Facilities for the Strength Assessment

- The points to be assessed are as follows:

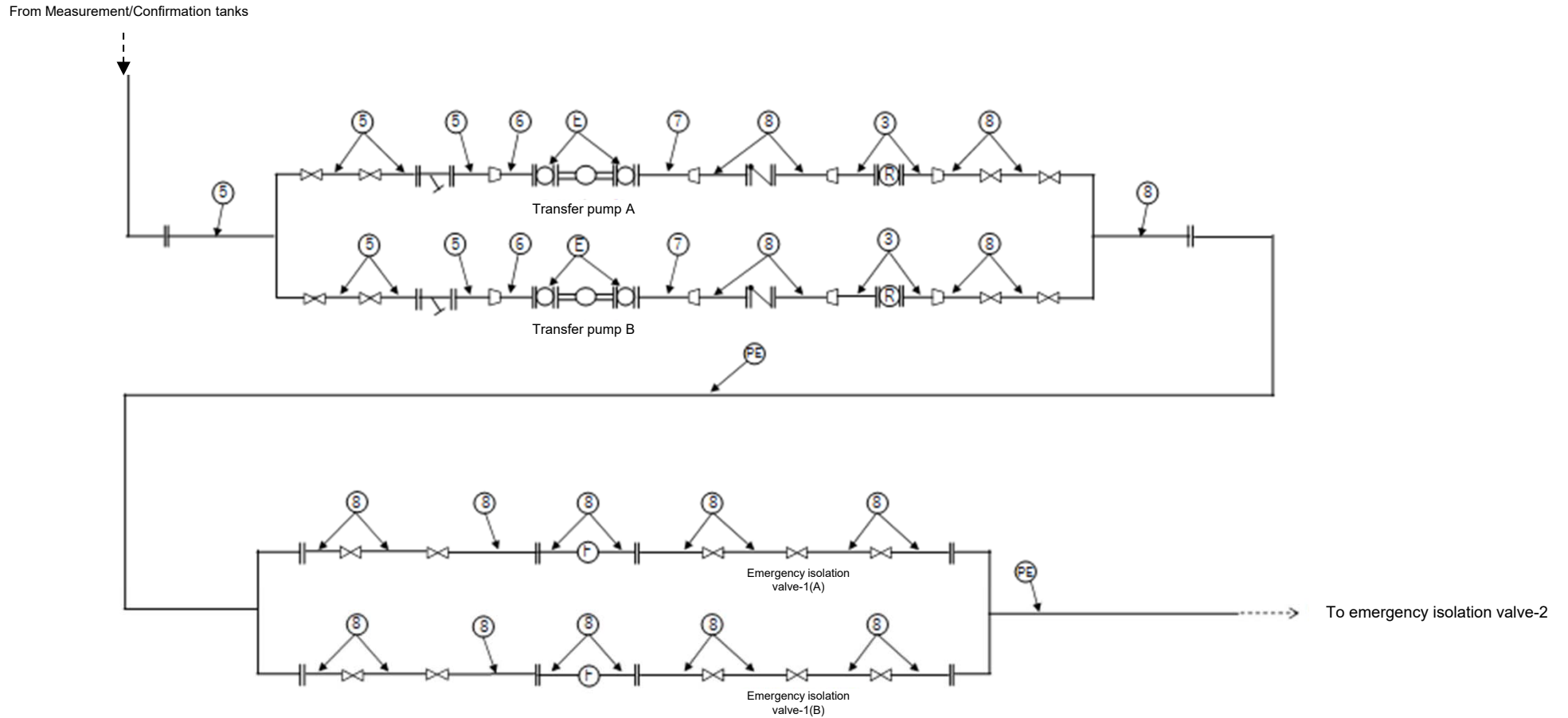

Fig. 1 Pipe diagram (4/5)

[Reference] Pipe Sections of ALPS Treated Water Dilution/Discharge Facilities for the Strength Assessment

Excerpt from document 1-1, the 3rd Review Meeting on the Implementation Plan Regarding the Handling of ALPS Treated Water



- The points to be assessed are as follows:

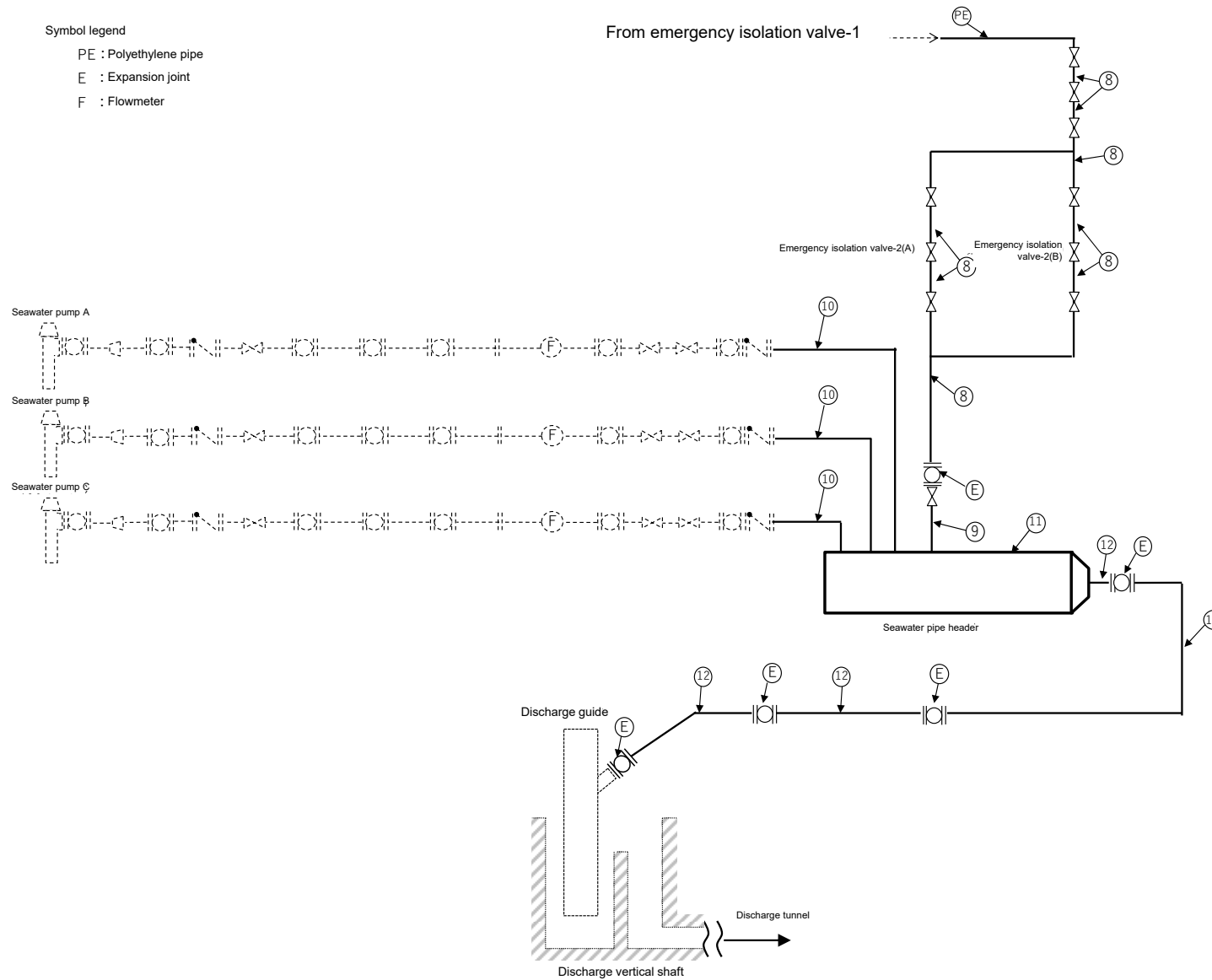

Fig. 1 Pipe diagram (5/5)

[Reference] Rationale of the calculation of exposure doses due to transfer into the air

■ Set values for exposure assessment

No.	Item	Value	Unit	Rationale of calculation
(1)	Estimated area to retain leaked water at the time of loss of functions	2201	m ²	Estimated area to retain leaked water at the time of loss of functions
(2)	Radioactive concentration	1.1E+06	Bq/L	The concentration of H-3 used for the assessment of doses at the site boundary was used.
(3)	Reference wind velocity	3.1	m/s	The reference wind velocity at 1F that is specified in the installation permit.
(4)	Evaporation coefficient	0.403	mm/day/mb	0.13 x Reference wind velocity (from the Lake Hefner formula (1954)) in Study Report 376008, Central Research Institute of Electric Power Industry)
(5)	Difference in saturated steam pressure on the water surface and a point 2 m just above the water surface	23.366	mb	Saturated vapor pressure estimated when the temperature on the water surface is assumed to be 20 ° C (tritium pressure in the air is assumed to be 0) (from the steam tables of the Japan Society of Mechanical Engineers)
(6)	Evaporation from water surface	9.42	mm/day	Evaporation coefficient × Difference in saturated steam pressure on the water surface and a point 2 m just above the water surface
(7)	Evaporation	2.40E-4	m ³ /s	Evaporation from water surface × Estimated area to retain leaked water at the time of loss of functions/1000 (mm/m)/24/3600 (s/day)
(8)	Relative concentration based on X/Q (Meteorological Guidelines)	1.9E-04	s/m ³	Derived from “Meteorological Guidelines for Safety Analysis of Nuclear Power Reactor Facilities” (Nuclear Safety Commission) (Implementation Plan III Chapter 3 2.2 Dose Assessment (Formula 2-2-1)) (Calculated with a discharge height of 0m, atmospheric stability D, wind velocity of 3.1 m, and distance from the closest assessment point No.70 of 442 m)
(9)	Respiratory rate	1.2	m ³ /h	The respiratory rate of adults during activities defined in the “Safety Assessment Review Guidelines for Light Water Nuclear Power Reactor Facilities” (Nuclear Safety Commission)
(10)	Continuous respiration time	336	h	Estimated recovery time from loss of functions (24-hour continuous respiration is assumed)
(11)	Effective dose coefficient for intake through inhalation	1.8E-08	mSv/Bq	Notice for specifying dose limits, etc., based on the provisions of the regulations regarding the refining of nuclear fuel materials or source materials, etc. (Attached Table 1)

[Reference] Assessment of exposure doses due to transfer into the air

■ Calculation of exposure doses (Enclosed numbers correspond to numbers on the previous page)

➤ Discharge rate

Radioactivity concentration (2) × Evaporation (7) × 1000 (L/m³) = 2.64 E + 5 Bq/m³

➤ Concentration at the site boundary

Discharge rate × Relative concentration based on X/Q (Meteorological guidelines) (8) = 5.01 E + 1 Bq/m³

➤ Exposure dose

Concentration at the site boundary × respiratory rate (9) × Continuous respiration time (10) × Effective dose coefficient for intake through inhalation (11) × 1000 (μSv/mSv) = **0.36 μSv/event**

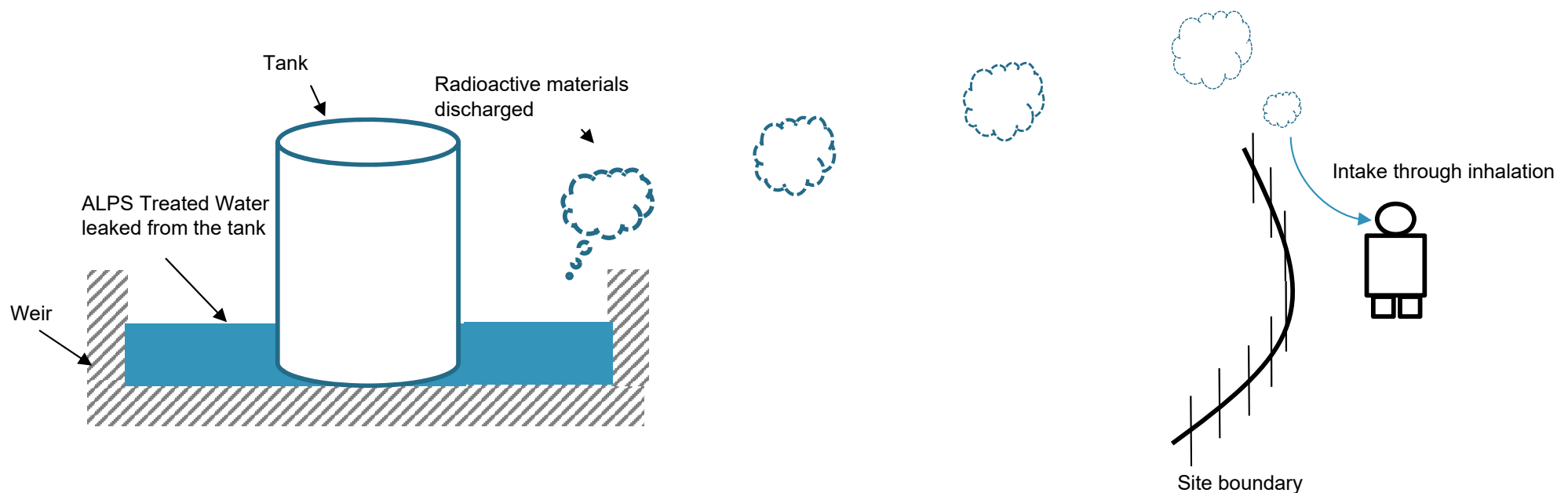

Conceptual diagram of exposure assessment

[Reference] Assessment of exposures due to liquid leakage

- Assumed “loss of functions of facilities” of the ALPS Treated Water dilution/discharge system
 - The ALPS Treated Water Dilution/Discharge Facilities was damaged due to an earthquake, and the stored water leaked.
 - The leaked water flowed out off-site through drainage channels, etc. To make the assessment conservative, it was not assumed the leaked water was diluted before being discharged.
 - An adult ingests 2 L of leaked water once.

- Estimated exposure: 32 μSv per event

Item		Unit	Radionuclides other than tritium	H-3	
Regulatory concentration		Bq/L	Even when the “sum of the ratios to regulatory concentration limits” of the major 7 nuclides other than tritium is set to 1, a conservative value in light of the fact that the recent record of the “sum of the ratios to regulatory concentration limits” of the major 7 radionuclides other than tritium is less than 1, the exposure dose is calculated based on the concept of regulatory concentration limit for underwater radionuclides*1 to be 1 mSv/year/365 days ≒ 3 μSv.	60,000	Total
Concentration in the tank for assessment				620,000*2	
[Reference]	K4 area A1 tank (Middle)			154,000	
	G1 area B1 tank			498,000	
Effective dose coefficient				μSv/Bq	
Intake		L/event	2		
Estimated exposure dose		μSv	10	22	32

*1: Concentration with which the average annual dose rate reaches 1 mSv if a person takes in 2 L of water every day from birth to age 70.

*2: Average concentration in all existing tanks

[Reference] Required functions of the ALPS Treated Water Dilution/Discharge Facilities

- [1] The discharge capacity into the sea must be larger than the amount of contaminated water generated (increase due to inflow of groundwater and rainwater).
- [2] To ensure that the undiluted water before discharge is ALPS treated water, the facilities must be able to homogenize the concentration of radioactive materials in a tank and a tank group and collect samples.
- [3] The facilities must dilute ALPS Treated Water with seawater and discharge it into the sea.
- [4] The facilities must be equipped with functions to immediately stop the discharge of ALPS Treated Water into the sea in the event of an abnormality.
- [5] The facilities must be capable of diluting ALPS Treated Water 100 times or more with seawater so that the tritium concentration in the diluted water becomes sufficiently below the regulatory concentration limit (60,000 Bq/L).

(Implementation Plan: II-2-50-1)

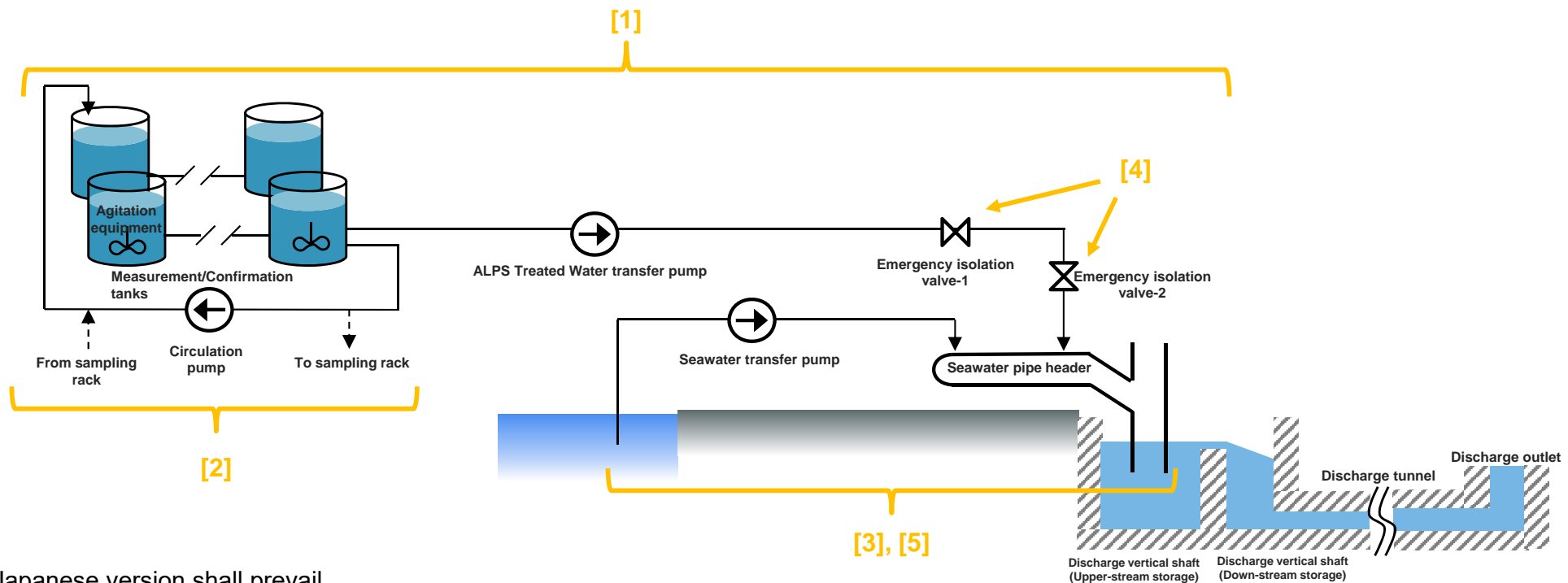

[Reference] Required functions of the Discharge Facility (1/2)

- (1) The facilities must be able to discharge the water from the ALPS Treated Water Dilution/Discharge Facilities (water diluted with seawater so that the sum of the ratios to regulatory concentrations limits of all radionuclides including tritium is less than 1) into the sea from a location approx. 1 km away from the coast. (Implementation Plan: II-2-50-7)

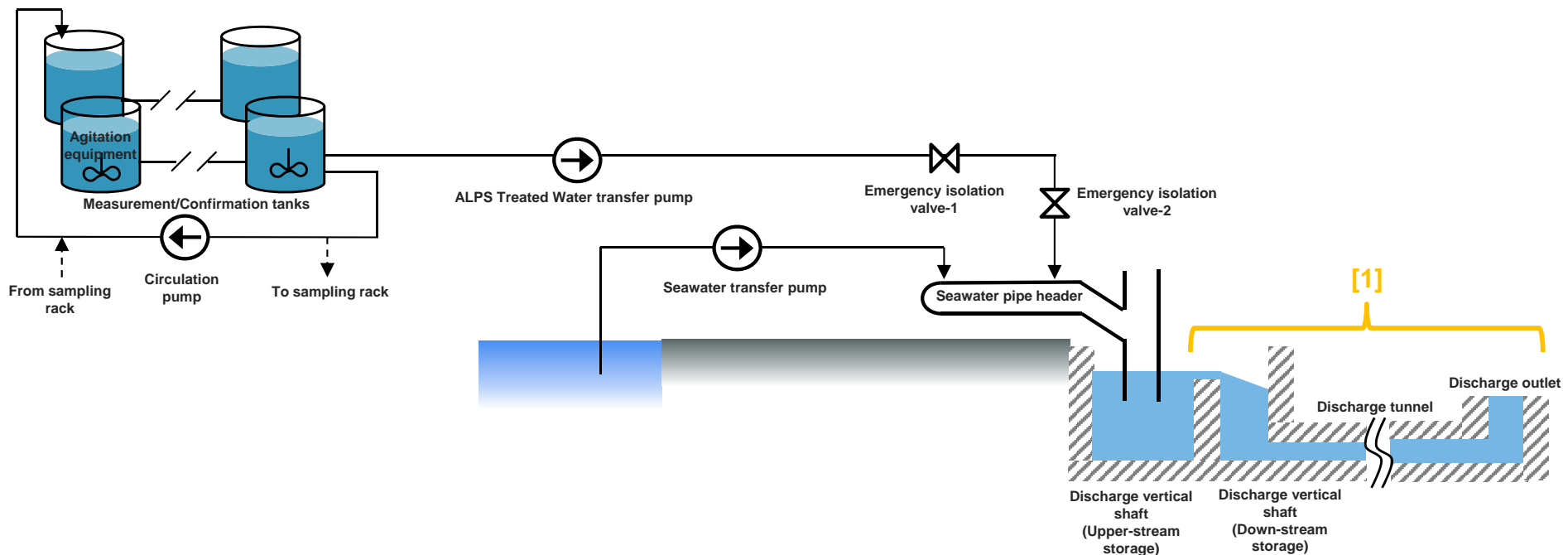



[Reference] Required functions of the Discharge Facility (2/2)

■ Concept of hydraulic design

- Pressure is discharged to the atmosphere from the discharge vertical shaft in order to reduce pressure in pipes.
- The structure of the discharge vertical shaft is linked to the tide level in the open ocean through the water discharge tunnel and outlet. It was confirmed that even when three seawater transfer pumps are in operation ($510,000 \text{ m}^3/\text{day} = 6 \text{ m}^3/\text{s}$), water can flow down-stream naturally using the water head difference between the discharge vertical shaft (down-stream storage) and the sea surface (about 1.8 m: total loss from the shaft to the outlet).
- Consideration is given to the rise in water level due to a surge in the event of an emergency shutdown.

List of water levels and elevations

Top end of the vertical shaft	T.P.+4.50m
Vertical shaft upper-stream level	T.P.+3.07m
Vertical shaft down-stream level	T.P.+2.54m
G.L.	T.P.+2.50m
Top end of the partition wall	T.P.+1.50m
H.W.L.	T.P.+0.76m
Top end of the discharge outlet	T.P.-11.9m
Lower end of the vertical shaft	T.P.-15.1m
Top end of the deepest part of the tunnel	T.P.-24.3m

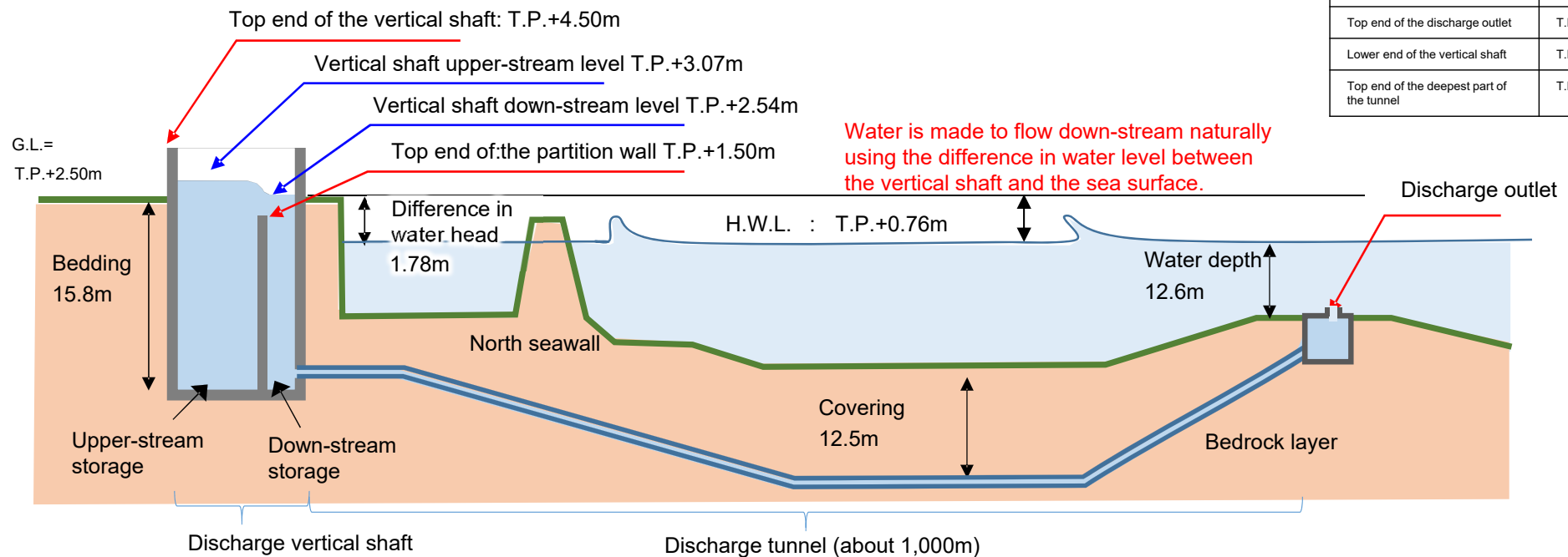

Conceptual diagram of Discharge Facility

[Reference] Overview of the ALPS Treated Water Dilution/Discharge Facilities

Objective

The facilities ensure that the water treated by Multi-Nuclide Removal System (ALPS) until the radionuclide concentration becomes sufficiently low is the ALPS Treated Water (that is the water in which sum of the ratios to regulatory concentration limits other than tritium is less than 1), and dilute the treated water with seawater, then discharge it into the sea.

Facilities Overview

The Measurement/Confirmation Facility homogenizes the concentration of radionuclides all tanks of the tank group in the status of measurement/confirmation, and then collects and analyzes samples to ensure that the water is ALPS treated water. Thereafter, the Transfer Facility sends the ALPS Treated Water to the seawater pipe header, and then the Dilution Facility dilutes the water with seawater taken in by the seawater transfer pump at the unit 5 intake channel until tritium concentration in it becomes less than 1,500 Bq/L, and discharge the water to the Discharge Facility.

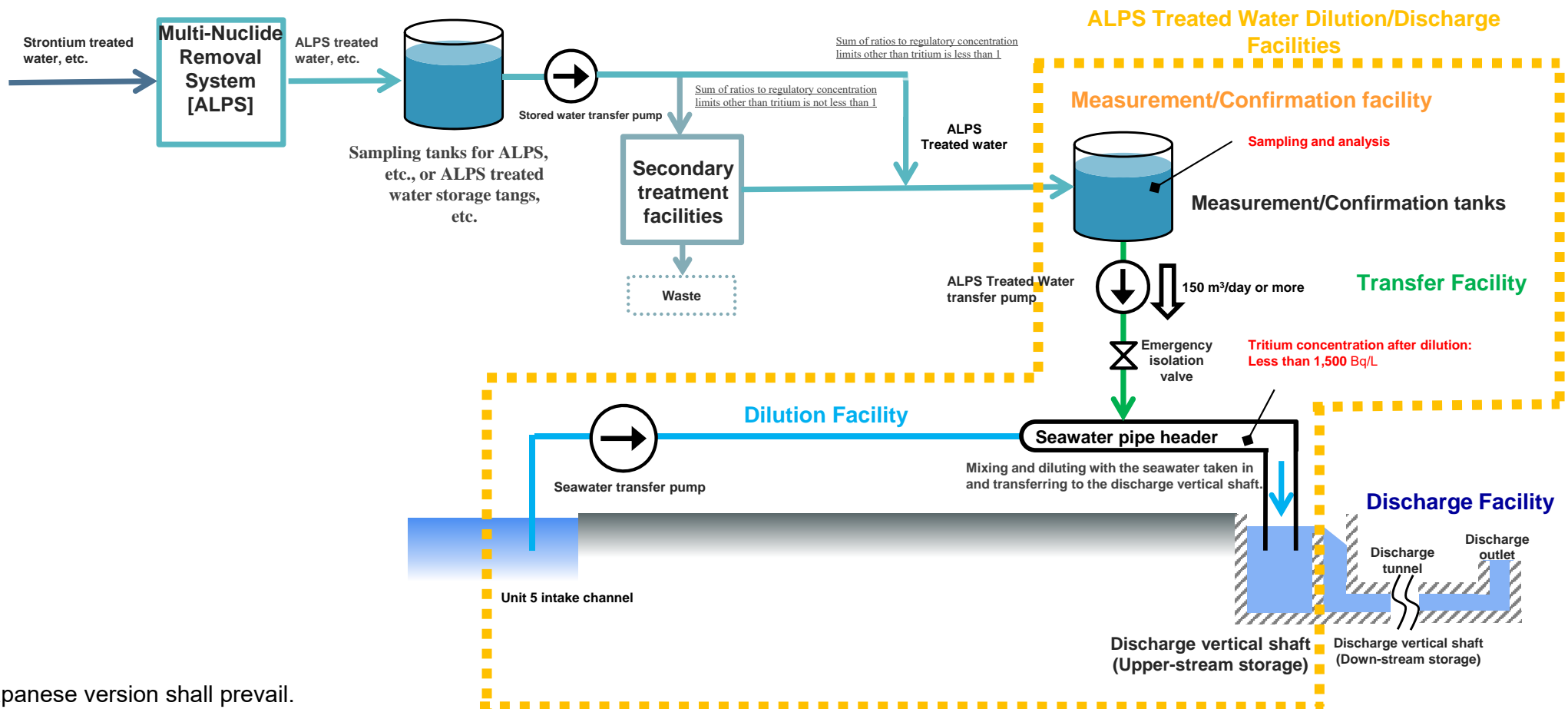

[Reference] Overview of the ALPS Treated Water Dilution/Discharge Facilities (Measurement/Confirmation facility)

Measurement/Confirmation facility

- K4 area tanks (approx. 30 000 m³ in total) are reused for the Measurement/Confirmation tanks, and each group from A to C consists of 10 tanks (approximately 1,000 m³ per unit).
- Each tank group takes the following steps (1) to (3) in rotation, and in the (2) Measurement/Confirmation process, water is circulated and stirred to become homogenized, and then sampled for analysis.

(1) Receiving process

ALPS Treated Water from ALPS Treated Water storage tanks, etc., is transferred into a group of empty tanks.

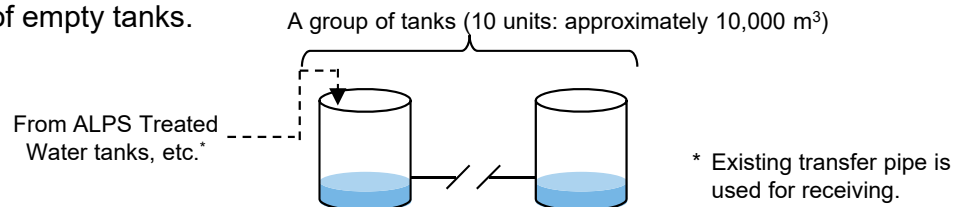

(2) Measurement/Confirmation process

After the quality of water in the tank group is homogenized by the agitation equipment and circulation pumps, the water is sampled to check if it meets the discharge standard.

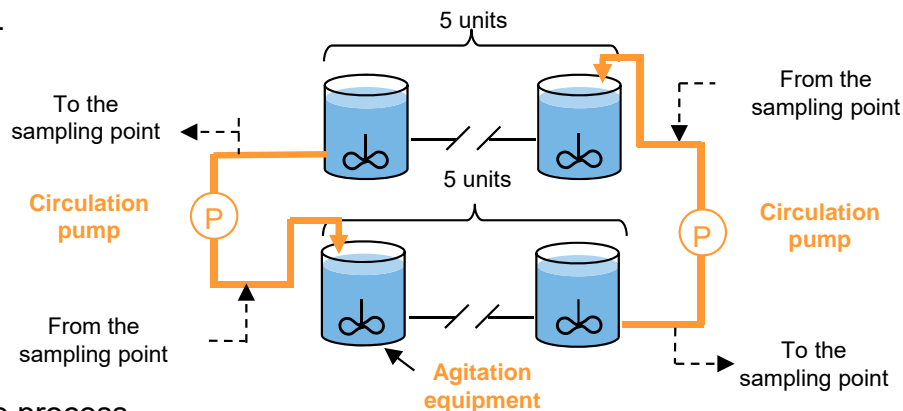

(3) Discharge process

After confirming that the ALPS Treated Water satisfies the discharge standard, the water is transferred to the Dilution Facility by the Transfer Facility.

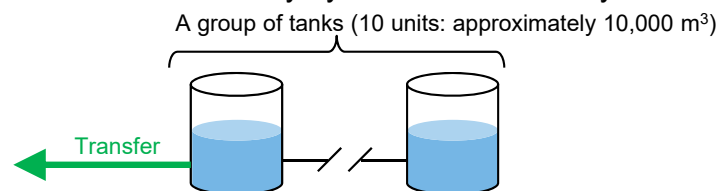

K4 area tank groups: (35 units)

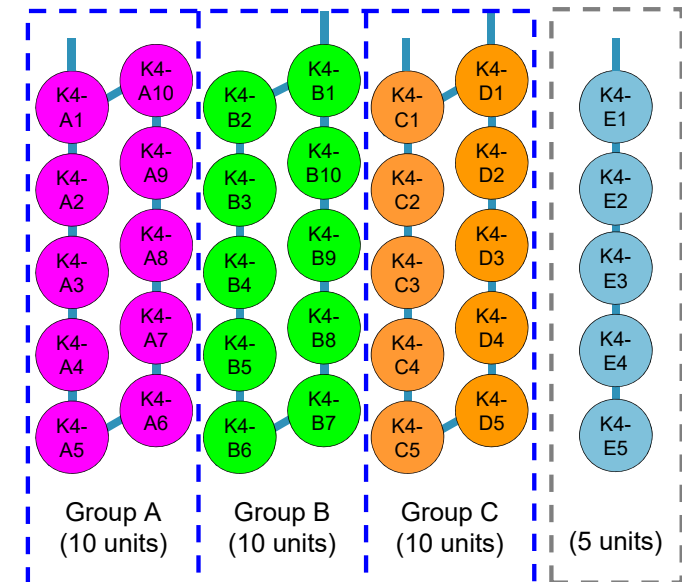

Chapter 2.50 ALPS Treated Water Dilution/Discharge Facilities

Chapter 2.5 ALPS Treated Water tanks

	Group A	Group B	Group C
1st cycle	Receiving	-	-
2nd cycle	Measurement/confirmation	Receiving	-
3rd cycle	Discharge	Measurement/confirmation	Receiving
4th cycle	Receiving	Discharge	Measurement/confirmation
...	Measurement/confirmation	Receiving	Discharge

[Reference] Overview of the ALPS Treated Water Dilution/Discharge Facilities (Transfer Facility)

Transfer Facility

- The Transfer Facility consists of ALPS Treated Water transfer pumps and transfer pipes.
- Two ALPS Treated Water transfer pumps are prepared, a unit in operation and the other backup unit, to transfer ALPS Treated Water from Measurement/Confirmation tanks to the Dilution Facility.
- Emergency isolation valves are provided both before the seawater piping header and in the seawall as a countermeasure against tsunami so that the transfer can be stopped immediately when an abnormality occurs.

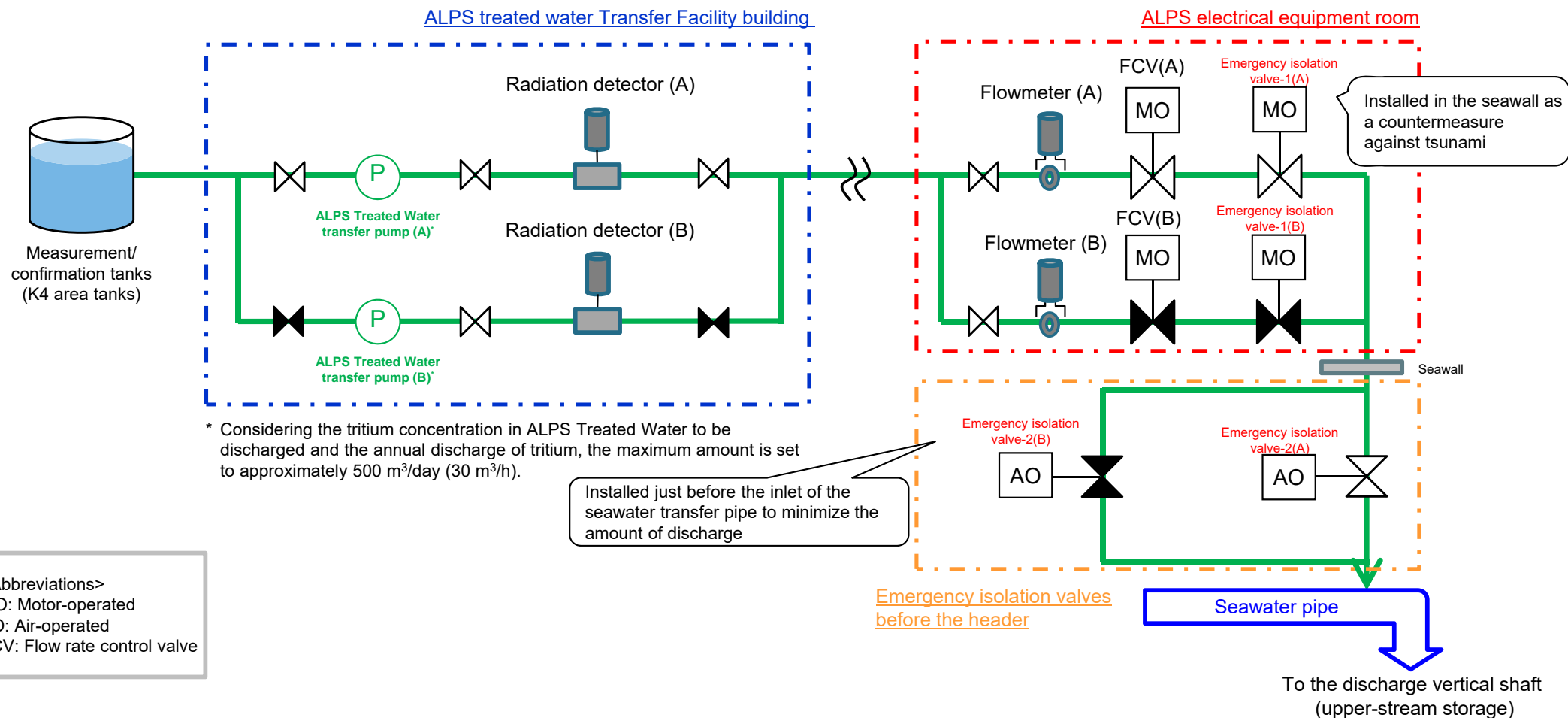

<Abbreviations>
 MO: Motor-operated
 AO: Air-operated
 FCV: Flow rate control valve

[Reference] Overview of the ALPS Treated Water Dilution/Discharge Facilities (Dilution Facility)

■ Dilution Facility

- Consisting of seawater transfer pumps, seawater pipe (including a header pipes), a discharge guide, and a discharge vertical shaft (upper-stream storage), the Dilution Facility diluted ALPS Treated Water with seawater, transfers it to the discharge vertical shaft (upper-stream storage), and discharge it to the Discharge Facility.
- The seawater transfer pumps have a capacity that can dilute ALPS Treated Water transferred by the Transfer Facility 100 times or more.

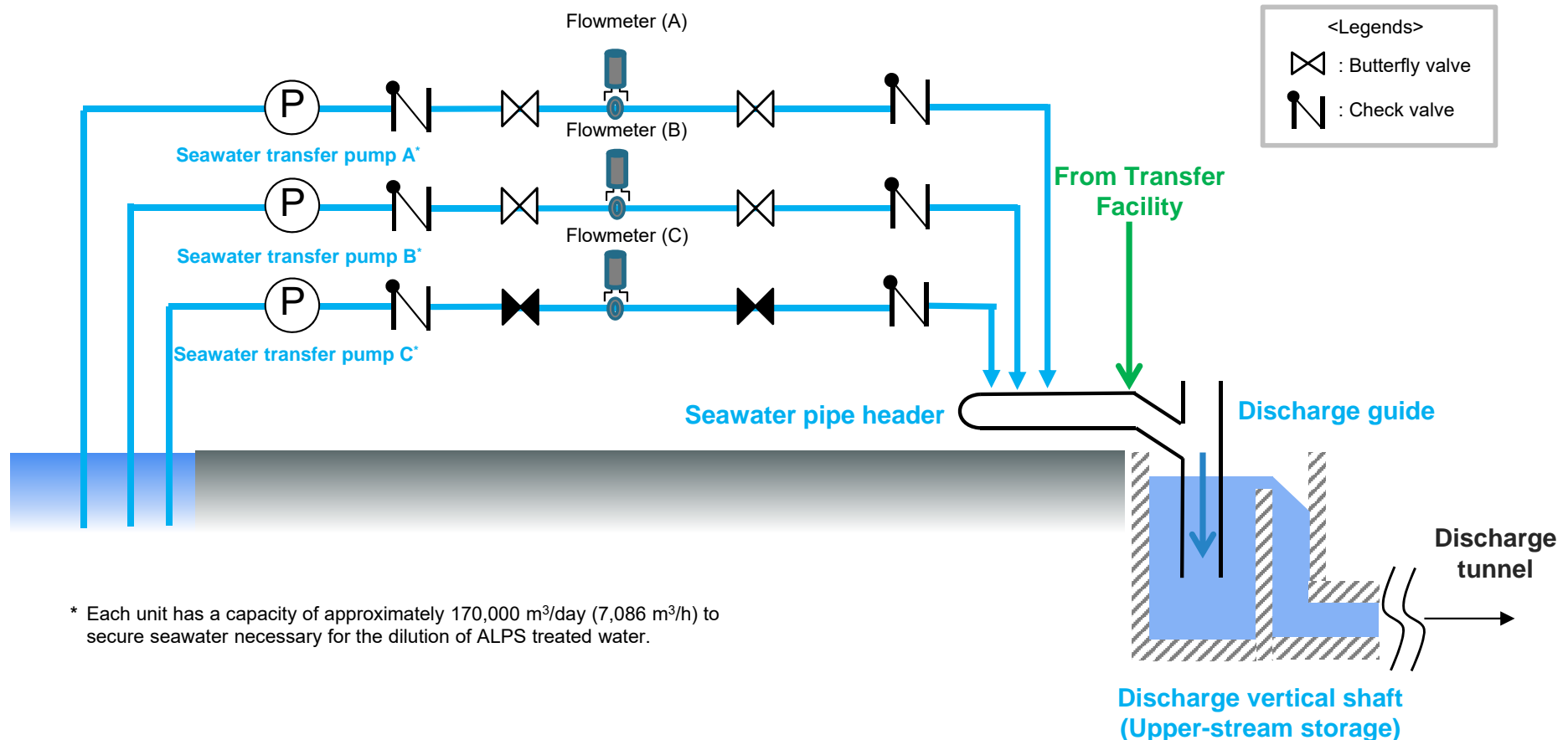

[Reference] Overview of the related facility (Discharge Facility)

Objective

Drainage water is discharged from the ALPS Treated Water Dilution/Discharge Facilities (water diluted with seawater so that the sum of which ratios to regulatory concentration limit including all nuclides together with tritium is less than 1) into the sea from a location approximately 1 km away from the coast.

Outline of the facilities

The Discharge Facility consist of a discharge vertical shaft (down-stream storage), a discharge tunnel, and a discharge outlet to achieve the above objective.

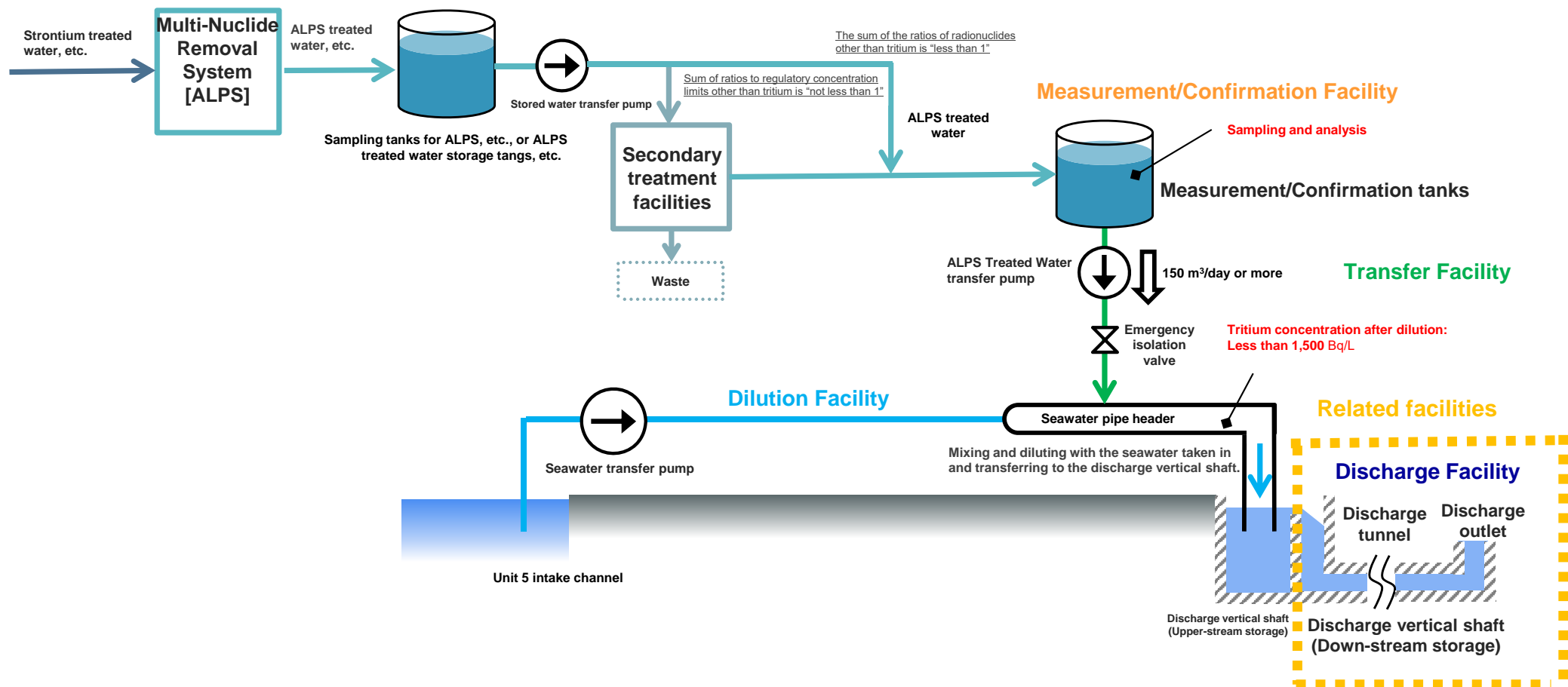

[Reference] Overview of the related facility (Discharge Facility) (1/2)

■ Discharge Facility

- Discharge Facility has a design so that they can transfer water flowing out over the partition wall in the discharge vertical shaft to the outlet, which is approximately 1 km away from the shore, by using the water head difference between water in the discharge vertical shaft (down-stream storage) and the sea surface. In addition, the design concept includes friction losses in the Discharge Facility and elevation of water surface.

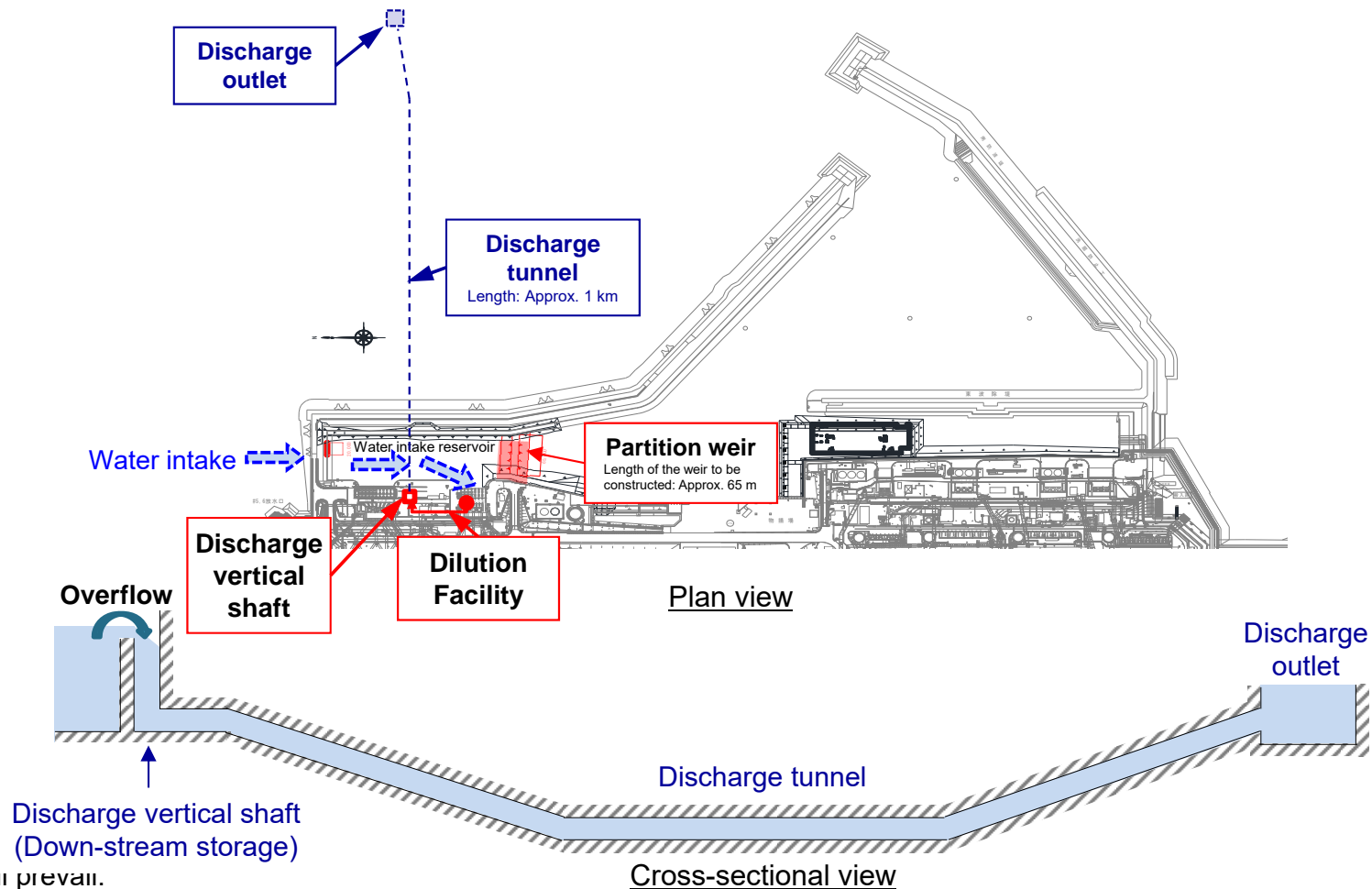

[Reference] Overview of the related facility (Discharge Facility) (2/2)

■ Overview of the structural design

- Water flows through the bedrock layer to minimize the leakage risk and to ensure a highly earthquake-resistant structure.
- A shield method is adopted and double-layer seals are installed in the reinforced concrete segment to ensure water cut-off performance.
- The tunnel body (segment) is designed considering the impacts of typhoons (high waves) and storm surges (sea level rise).

■ Construction of tunnel (shield method)

- As there are many discharge tunnels constructed by the shield method, this secure construction will minimize the possibility of trouble.

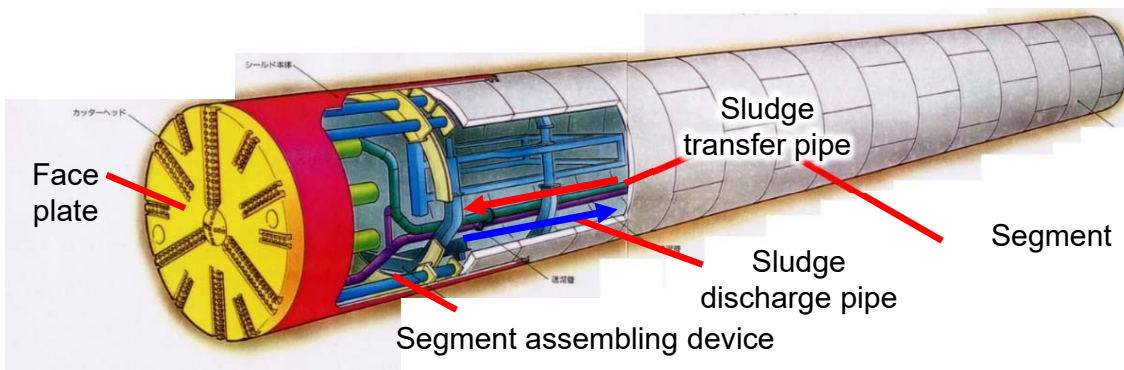

*Slurry shield method was adopted this time.

Schematic diagram of a shield machine

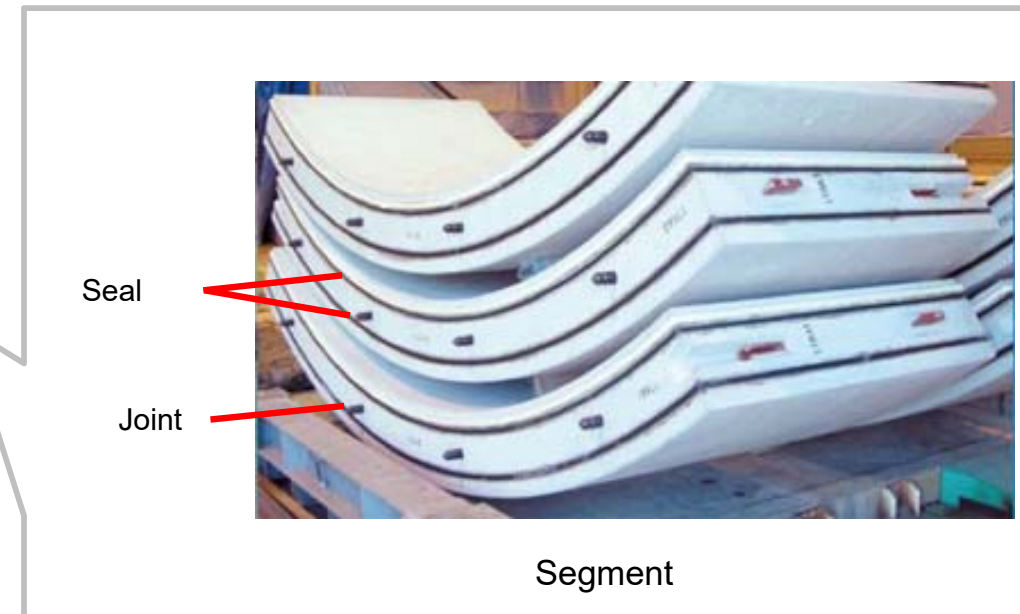

Segment

[Reference] Layout plan of ALPS Treated Water Dilution/Discharge Facilities and the related facility

- The layout of ALPS Treated Water Dilution/Discharge Facilities and the related facility is as follows.
(Implementation Plan: II-2-50-Attachment 1-2)

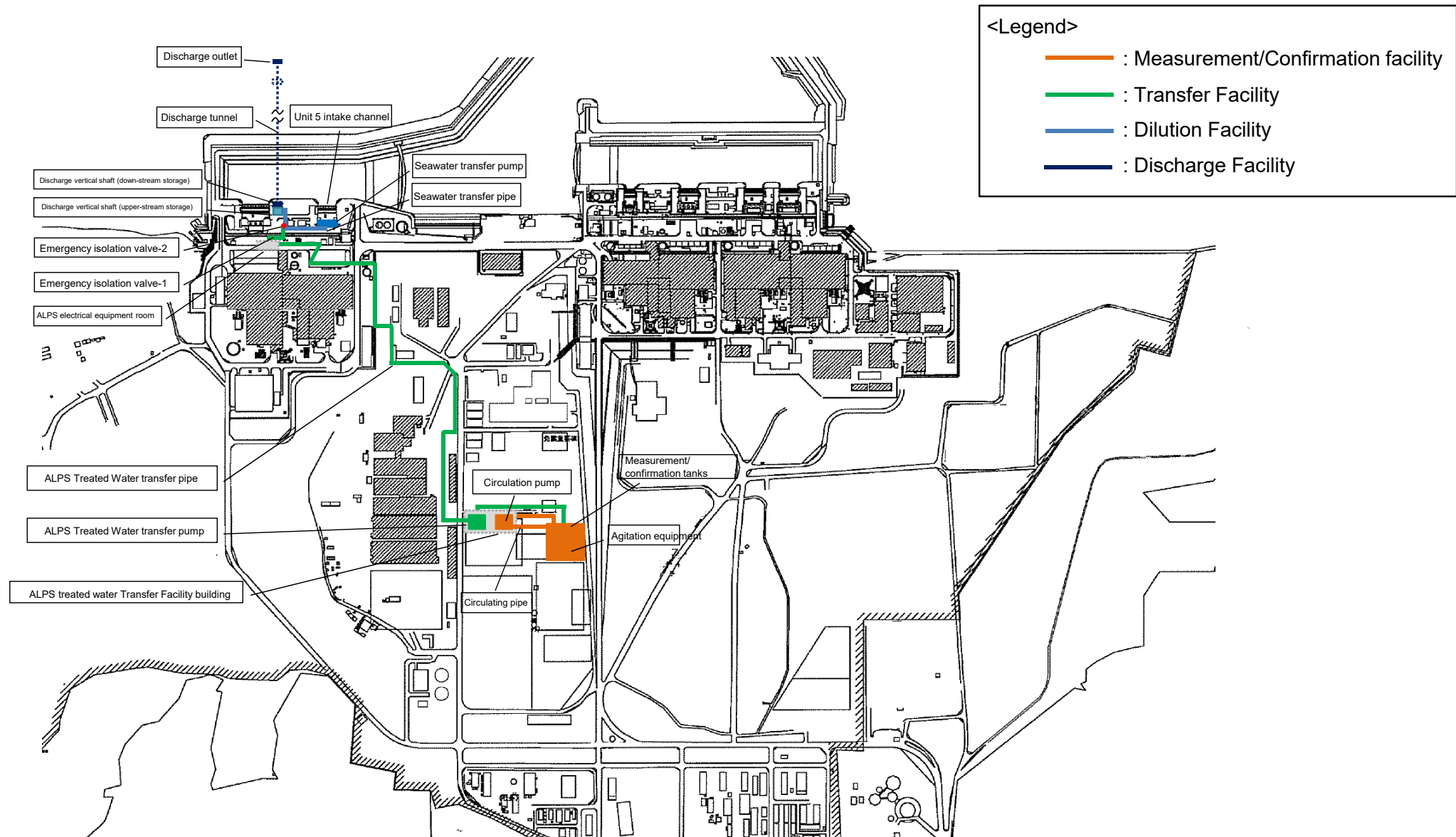

[Reference] Facility overview for ensuring safety

Source: This map was created by Tokyo Electric Power Company Holdings, Inc. based on a map published by the Geographical Survey Institute (Electronic Map Web) <https://maps.gsi.go.jp/#13/37.422730/141.044970/&base=std&ls=std&disp=1&vs=c1j0h0k0l0u0i0z0r0s0m0f1>

Secondary treatment facility (new reverse osmosis membrane equipment)

Secondarily treats treated water to be purified in which the sum of ratios to regulatory concentration limits other than tritium is "1 to 10".

Secondary treatment facility (ALPS)

Secondarily treats treated water to be purified in which the sum of ratios to regulatory concentration limits other than tritium is "not less than 1".

Measurement/Confirmation facility (K4 tank groups)

Consists of 3 groups, each of which is responsible for receiving, measurement/confirmation, and discharge. In the Measurement/Confirmation process, water is circulated and agitated to become homogenized, and then sampled for analysis. (Approx. 10,000 m³ × 3 groups)

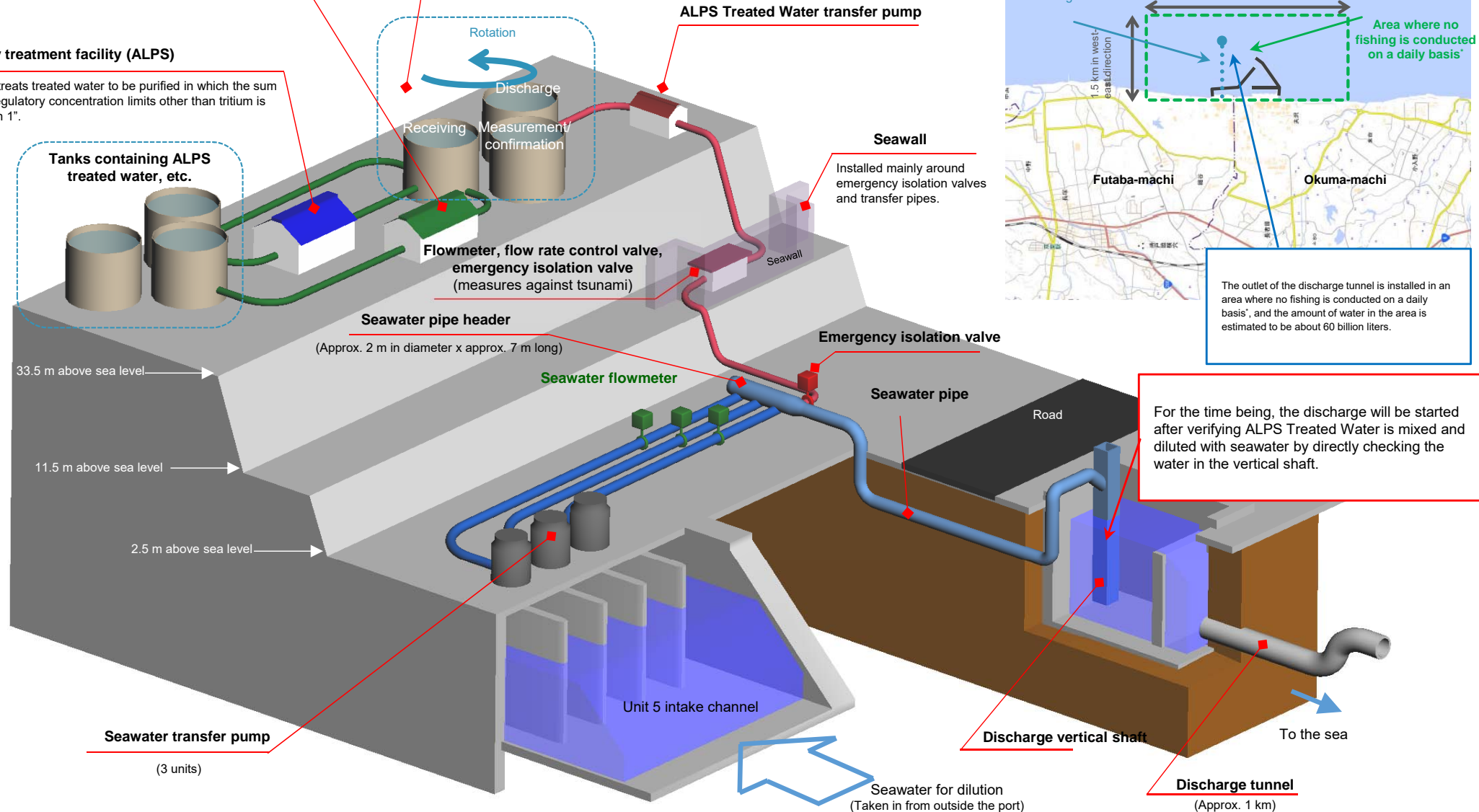

For the time being, the discharge will be started after verifying ALPS Treated Water is mixed and diluted with seawater by directly checking the water in the vertical shaft.

The outlet of the discharge tunnel is installed in an area where no fishing is conducted on a daily basis, and the amount of water in the area is estimated to be about 60 billion liters.