

Installation of the ALPS Treated Water dilution/Discharge Facilities and the Related Facility



December 24, 2021

Tokyo Electric Power Company Holdings, Inc.

1. Overview of Amendments in the Application for Approval of Amendments to the Implementation Plan for specified nuclear facilities Concerning Installation of the ALPS Treated Water Dilution/Discharge Facilities and the Related Facility
2. Details of the approval application for amend to the implementation plan for the installation of the ALPS Treated Water Dilution/Discharge Facilities and the Related Facility for specified nuclear facilities

1. Overview of Amendments in the Application for Approval of Amendments to the Implementation Plan for specified nuclear facilities Concerning Installation of the ALPS Treated Water dilution/discharge Facilities and the Related Facility

1-1. Overview of ALPS Treated Water Dilution/Discharge Facilities

Objective

Water from which radioactive nuclides has been removed using ALPS until the radionuclide concentration is at a sufficiently low concentration, will be diluted with seawater and discharged into the sea after confirming that the water meets the regulatory limit (the sum of ratios to regulatory concentration limit must be less than 1).

Facility overview

In the Measurement/Confirmation Facility, once the radionuclide in the water in the measurement/confirmation tank are uniformly dispersed, samples are taken and analyzed to confirm the water is right ALPS treated water, which meets regulatory standards. The ALPS Treated Water is then transferred to the seawater pipe header using the transfer facility and mixed with the seawater taken from the Unit 5 intake channel using the dilution facility until the tritium concentration is below 1,500 Bq/L. This is then discharged using the discharge facility.

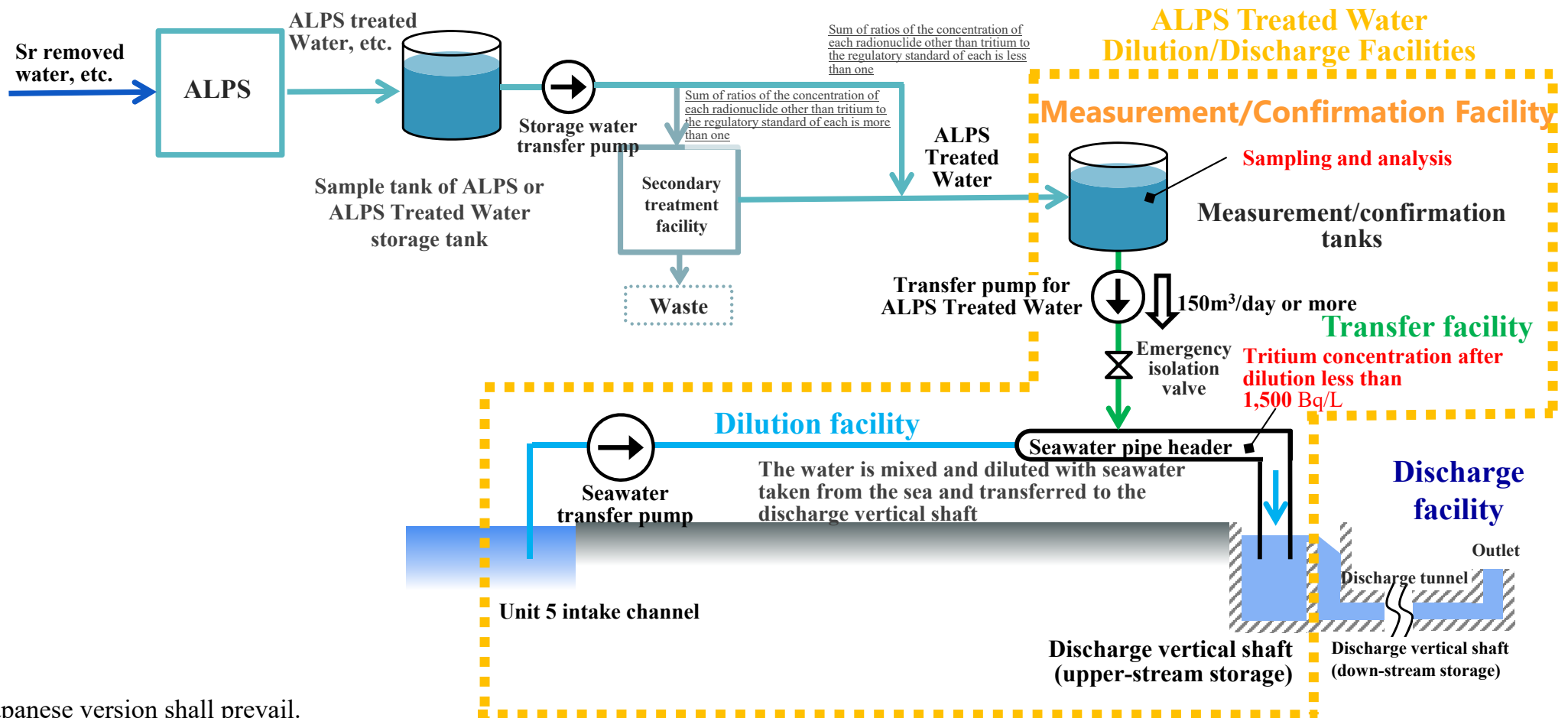

1-2. ALPS Treated Water Dilution/Discharge Facilities (Measurement/Confirmation Facility)

Measurement/Confirmation Facility

- K4 area tanks (total amount approx. 30,000 m³) will be co-opted as Measurement/Confirmation tanks. 10 tanks of each will be taken from groups A, B, and C (each tank has a capacity of around 1,000 m³).
- Each tank group is charged with processes ① through ③ in rotation, and in the ② Measuring/confirmation process, water that has been made uniform through circulating and stirring will be sampled and analyzed.

① Receiving process

Receive ALPS Treated Water from the ALPS Treated Water storage tank into an empty tank.

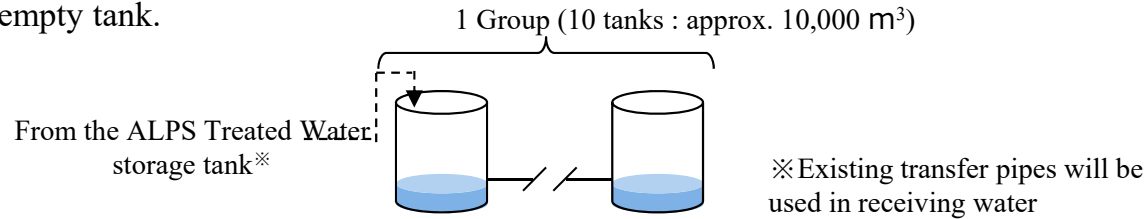

② Measuring/confirmation process

After making the quality of the water in the tanks uniform using the Agitation equipment and circulation pumps, samples are taken to see if the water meets the discharge criteria.

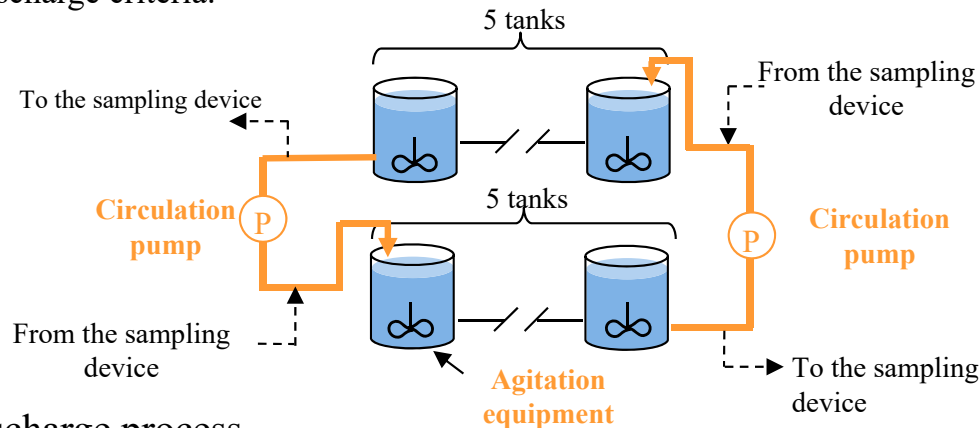

③ Discharge process

After confirming the water meets the discharge criteria, the ALPS Treated Water is transferred via the transfer facility to the dilution facility.

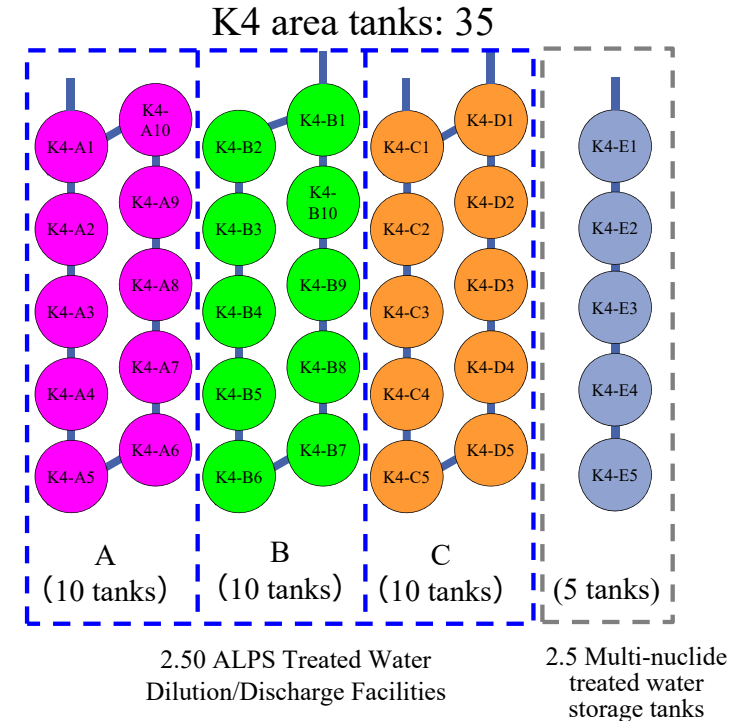
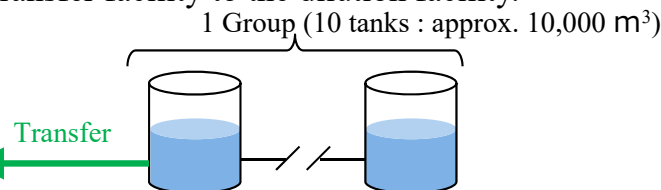

	A	B	C
1 st round	Receiving	—	—
2 nd round	Measurement and confirmation	Receiving	—
3 rd round	Discharge	Measurement and confirmation	Receiving
4 th round	Receiving	Discharge	Measurement and confirmation
...	Measurement and confirmation	Receiving	Discharge

1-2. ALPS Treated Water Dilution/Discharge Facilities (Transfer Facility)

Transfer facility

- The transfer facility is comprised of the ALPS Treated Water transfer pumps and transfer pipes.
- ALPS Treated Water transfer pump is comprised of two units, the operating unit and the reserve. It transfers the ALPS Treated Water from the Measurement/Confirmation tank to the dilution facility.
- Two emergency isolation valves will be installed, one before the seawater pipe header to be able to stop transfer swiftly in an emergency and another inside the seawall, as a tsunami measure.

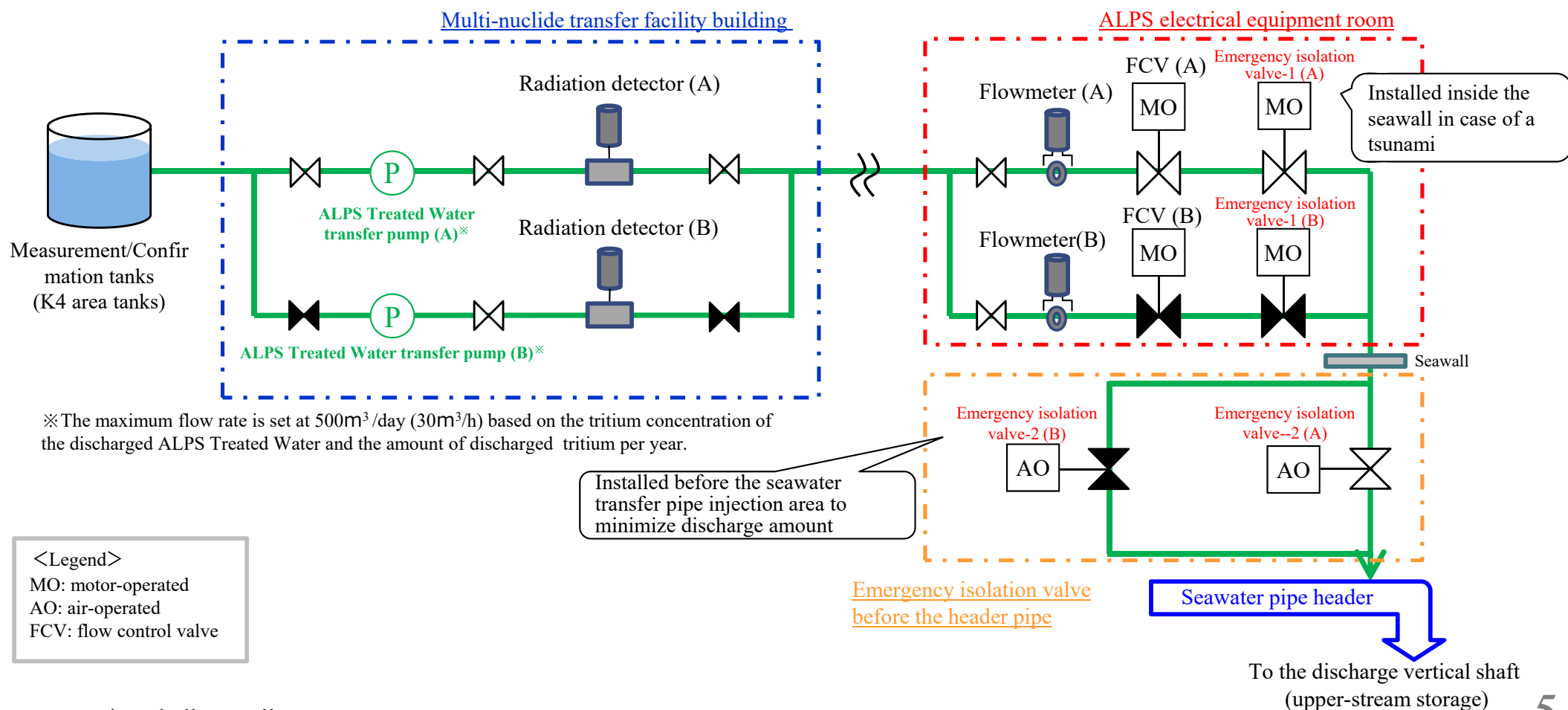

1-2. ALPS Treated Water Dilution/Discharge Facility (Dilution Facility)

■ Dilution facility

- The dilution facility is comprised of the seawater transfer pump, seawater pipe (including header pipe), discharge guide, and discharge vertical shaft (upper-stream storage). It will dilute ALPS Treated Water using seawater and then transfer the diluted water to the discharge vertical shaft (upper-stream storage), and to the discharge facility.
- The seawater transfer pump will have a capacity that allows ALPS Treated Water transferred using the transfer facility to be diluted by more than 100 times.

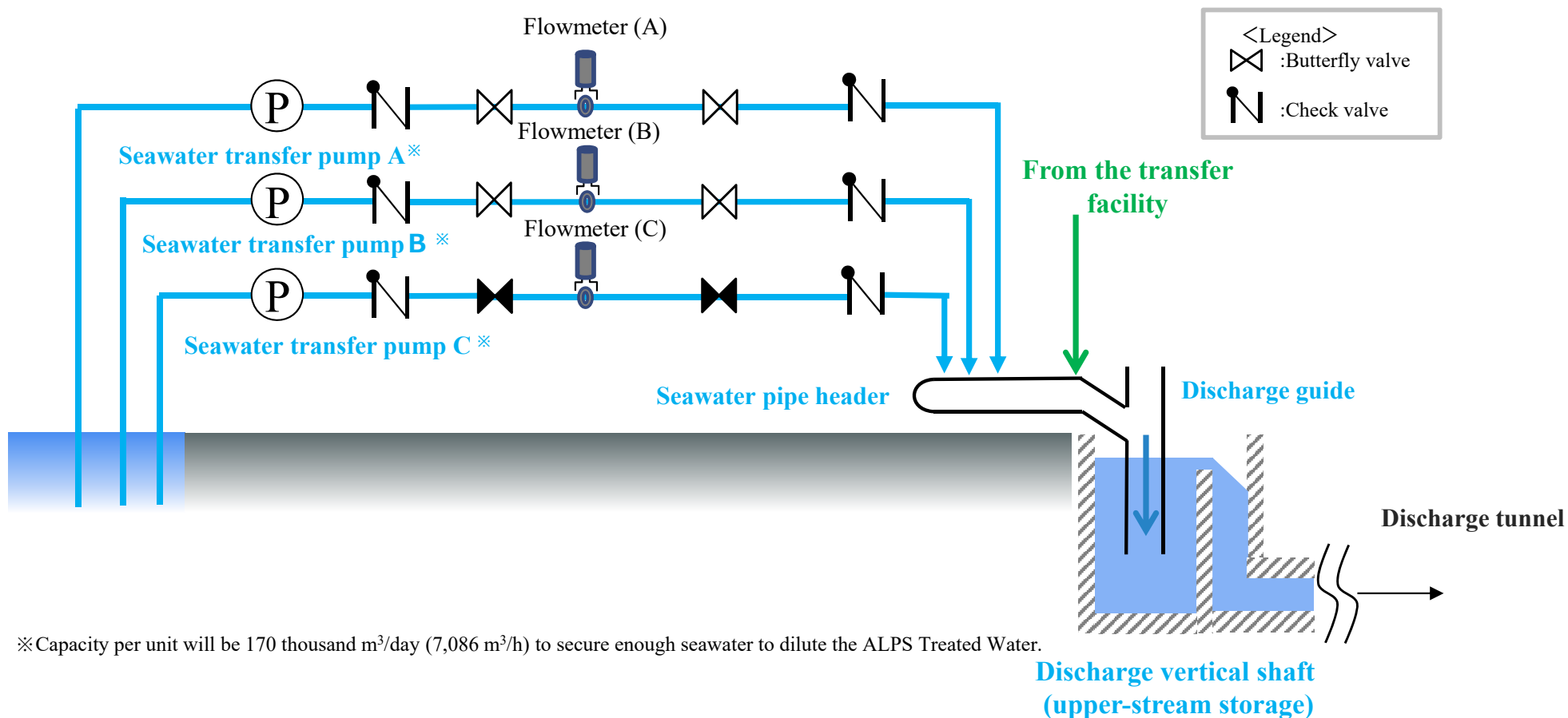

1-3. Objective and Facility overview of the Related Facility (Discharge Facility)

Objective

The water from the ALPS Treated Water Dilution/Discharge Facilities will discharge into the sea at a location 1km from the Fukushima Daiichi Nuclear Power Station. The water discharged must be diluted by seawater to have the value less than 1 to meet the sum of ratios to regulatory concentrations limit, including tritium)

Facility overview

The discharge facility will be comprised of the Discharge vertical shaft (down-stream storage), discharge tunnel and discharge outlet to achieve the objective above.

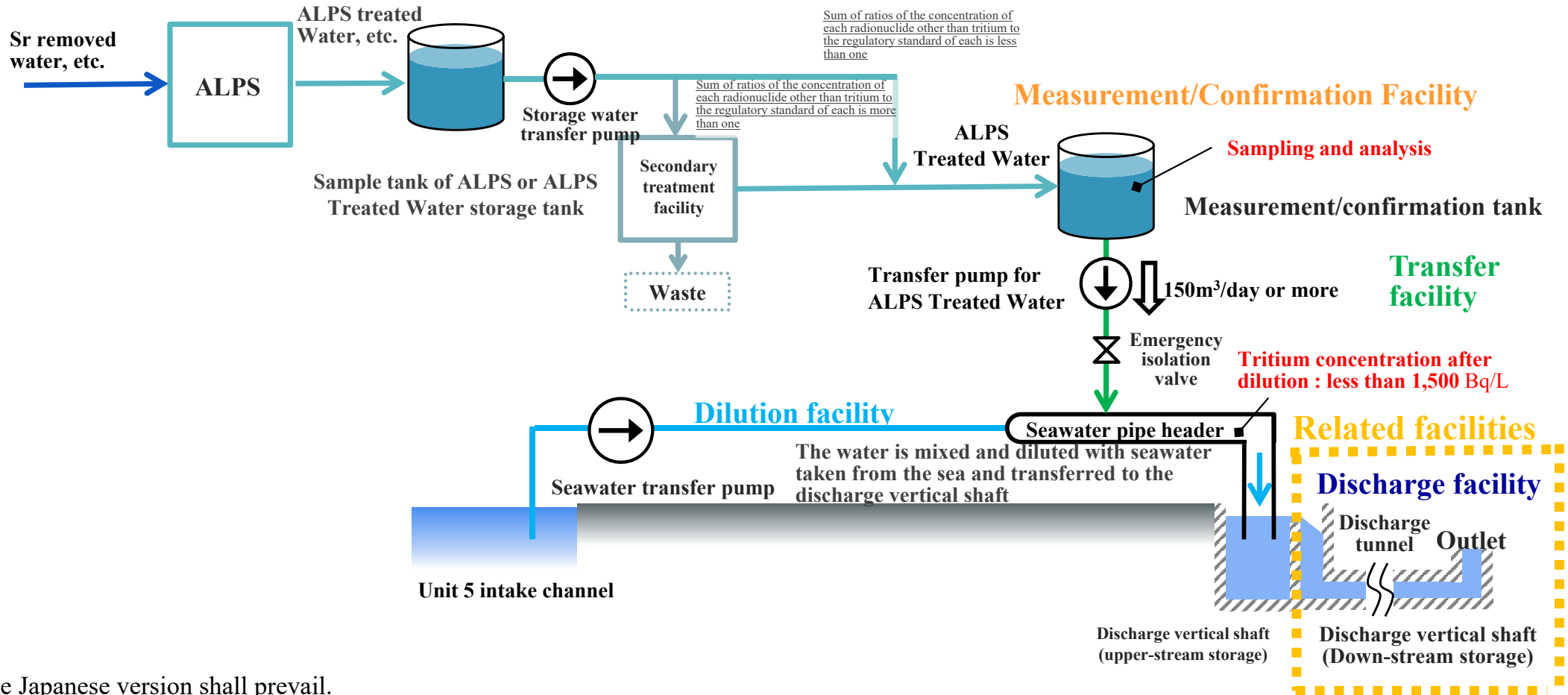

1-4. Overview of the Related Facility (Discharge Facility) (1/2)

Discharge Facility

- The discharge facility is designed so that the water that has spilled over the partition in the discharge vertical shaft will be transferred to the outlet 1 km away due to the differential head between the discharge vertical shaft (down-stream storage) and sea surface. The design will take into account friction loss and rising water levels in the discharge facility.

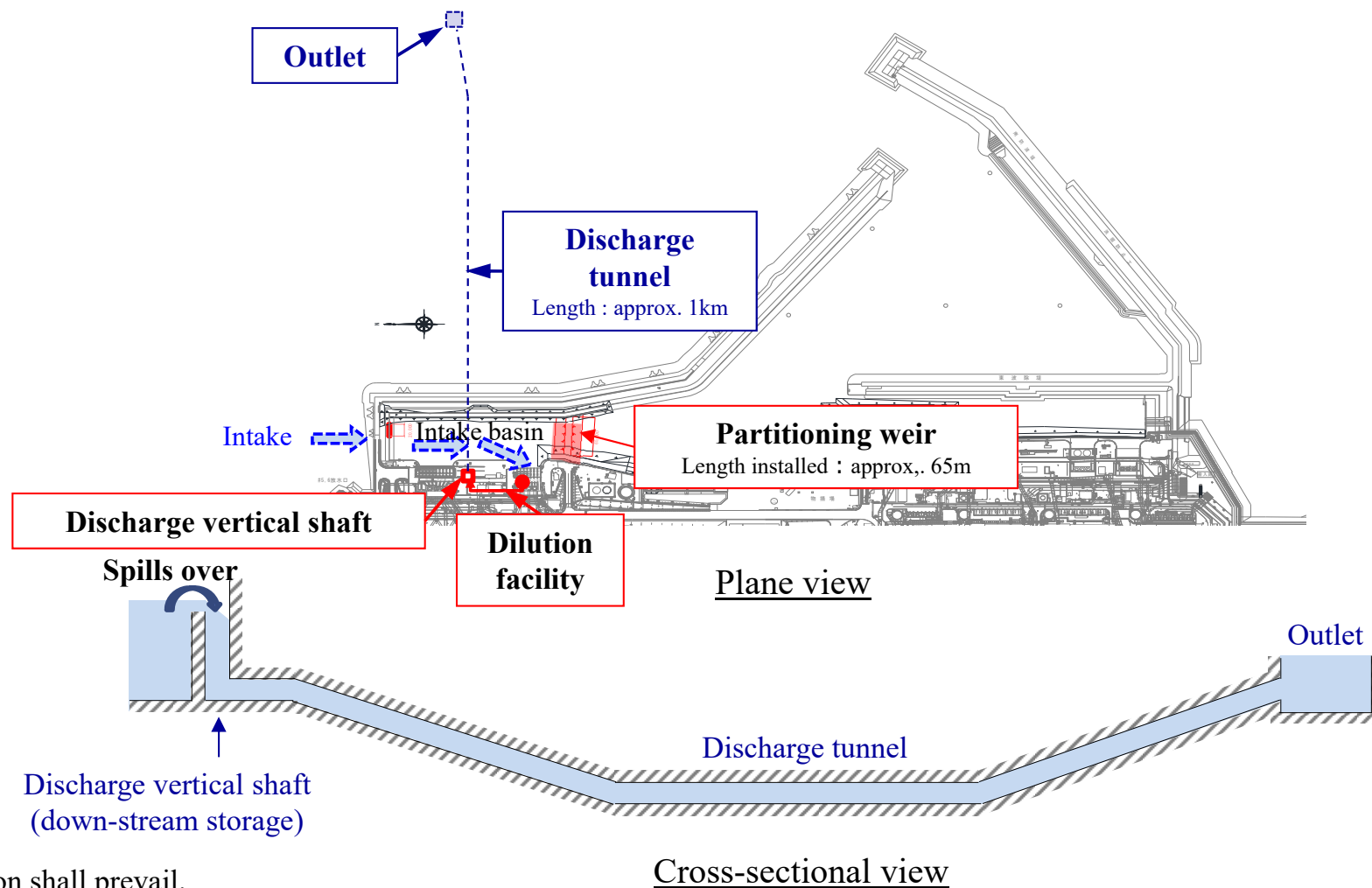

1.4. Overview of the Related Facility (Discharge Facility) (2/2)

Overview of Structural Design

- Because it goes through the rock base layer, the structure will be highly resistant against any earthquakes and the risk of water leakage will be low.
- The shield method will be used in construction. It will be made waterproof through the use of two layers of sealing material in the reinforced concrete segment.
- The tunnel structure (segment) is designed considering the effects of typhoons (high waves) and storm surges (sea level rise).

Tunneling (Shield Method)

- There are many examples of seabed tunnels being built using shield method and therefore the probability of any problems occurring is deemed low by secure construction work.

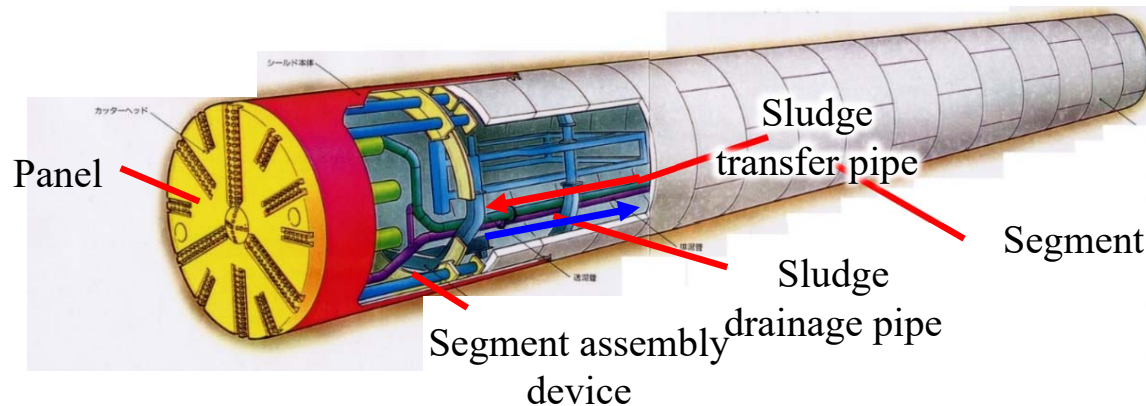

*The slurry shield tunneling will be used for this project

Overview of shield machine

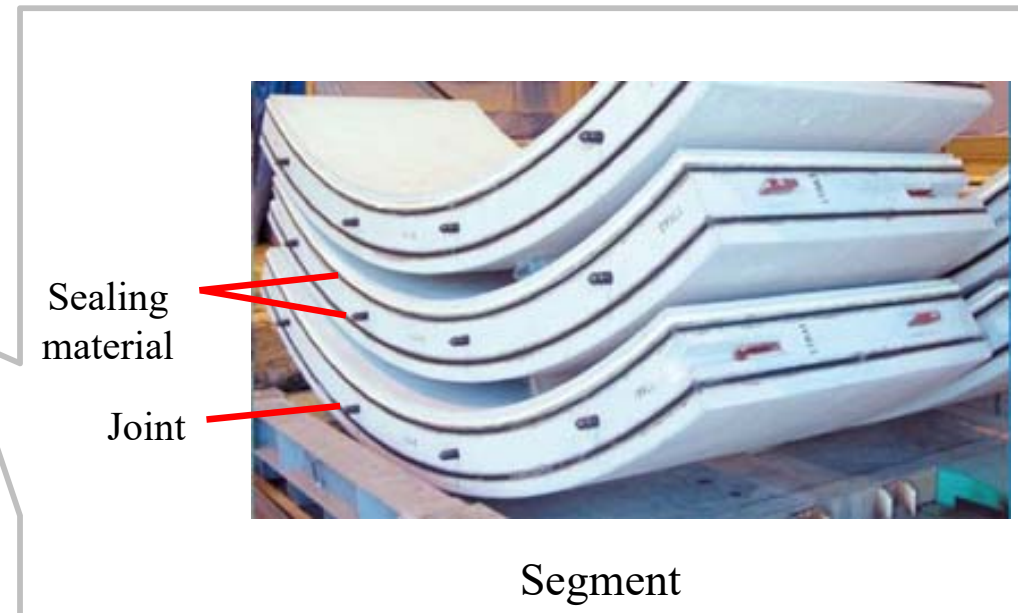

Segment

1-5. Site plan for the ALPS Treated Water Dilution/Discharge Facilities and related facilities

- The ALPS Treated Water Dilution/Discharge Facilities and the Related Facility will be located as follows. (Implementation plan: II-2-50-Att1-2)

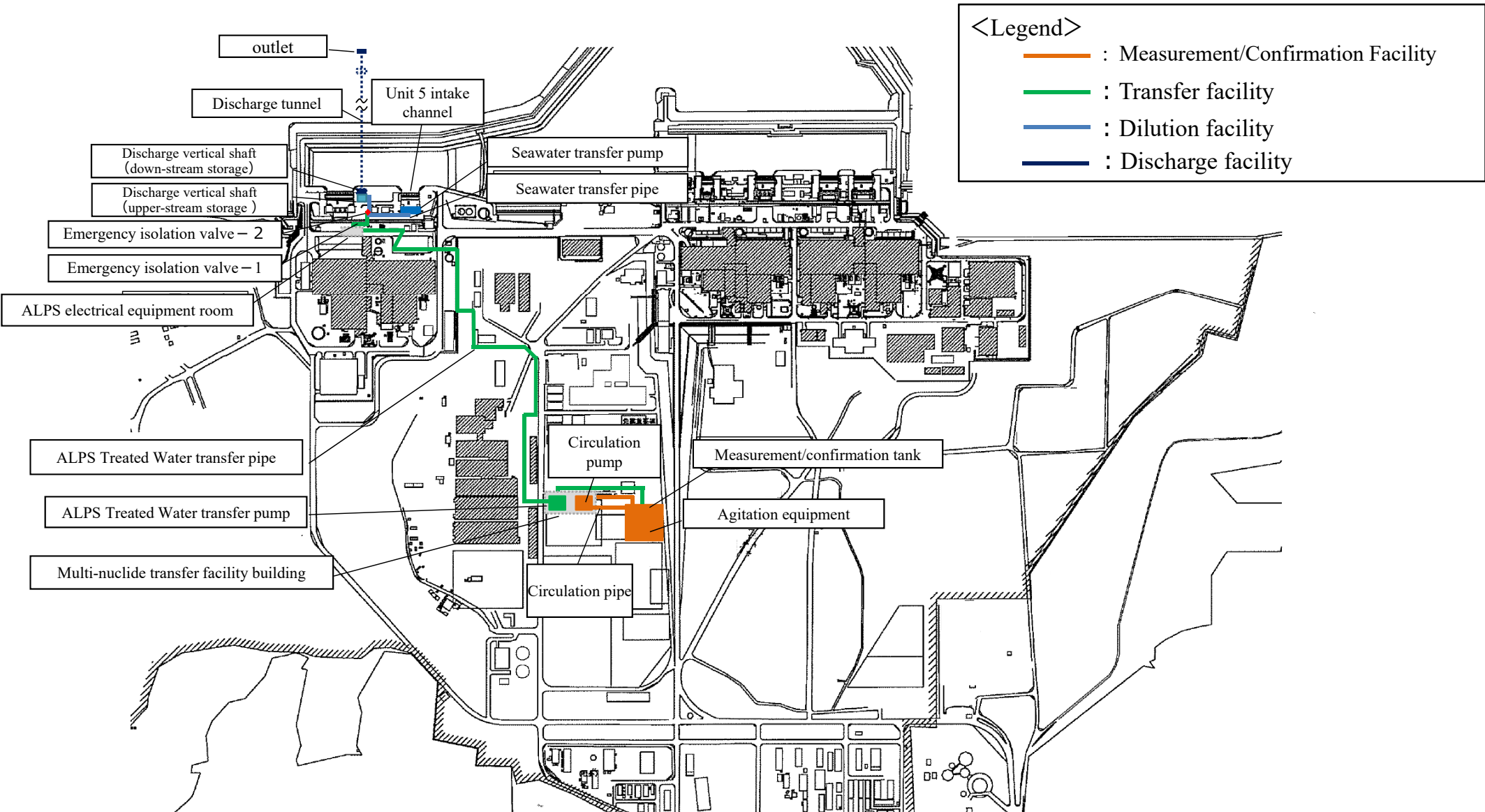

(Reference) Overview of facilities for securing safety

Source: Developed by Tokyo Electric Power Company Holdings, Inc. based on the map developed by the Geospatial Information Authority of Japan (electronic territory web) <https://maps.gsi.go.jp/#13/37.422730/141.044970/&base=std&ls=std&disp=1&vs=c1j0h0k010u0t0z0r0s0m0f1>

Secondary treatment facility (newly installed reverse osmosis membrane facility)

Secondary treatment of Treated Water to be re-purified (sum of ratios to regulatory concentration limit, excluding tritium, is between 1 and 10)

Secondary treatment facility (ALPS)

Secondary treatment of Treated Water to be re-purified (sum of ratios to regulatory concentration limit, excluding tritium, is 1 or higher)

Measurement/Confirmation Facility (K4 tank group)

Comprised of three sets of tank groups each with the role of receiving, measurement/confirmation and discharge. In the measurement/confirmation stage, water that has been made uniform through circulation and stirring is sampled and analyzed (approx. 10,000m³×3 groups)

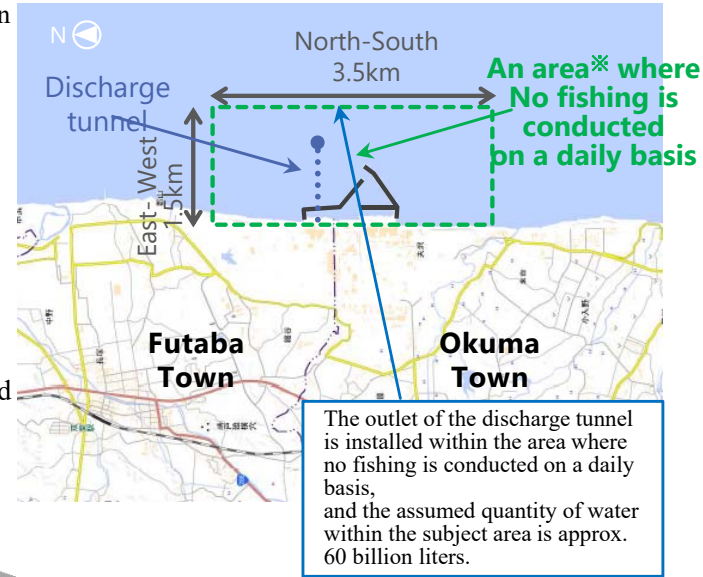
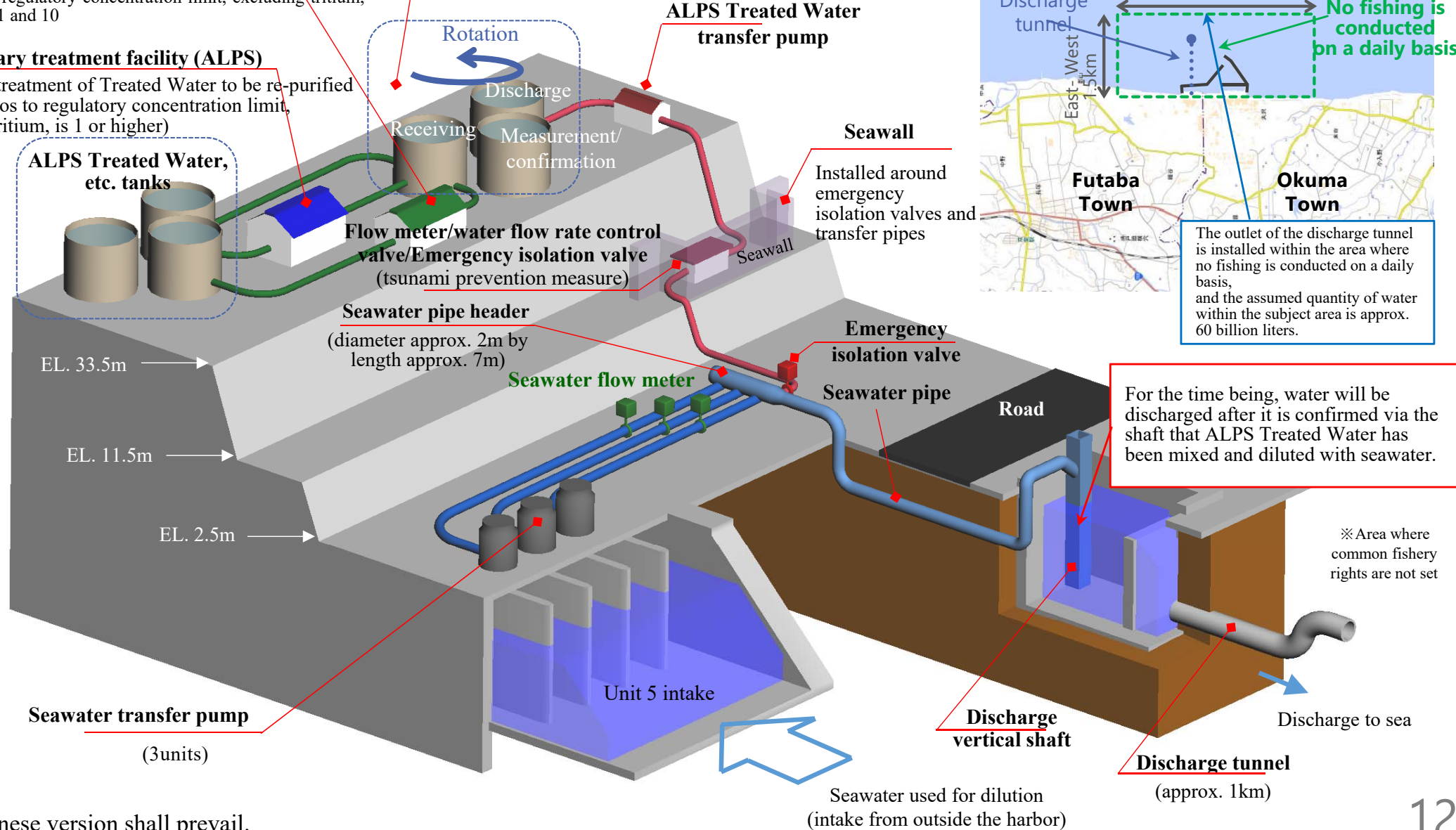

For the time being, water will be discharged after it is confirmed via the shaft that ALPS Treated Water has been mixed and diluted with seawater.

※ Area where common fishery rights are not set

2. Details of the approval application for amend to the implementation plan for the installation of the ALPS Treated Water Dilution/Discharge Facilities and the Related Facility for Specified Nuclear Facility

2.1 Outline of amendment to the implementation plan

- This section provides an overview of the application for amend the implementation plan.

Description	Page number
2.2 Application for approval of amendment to the implementation plan	P15~17
2.3 ALPS Treatment Water Dilute Release Facility	
(1) Required function	P18
(2) Confirmation of items required for measures which should be taken※	P19~51
2.4 Water Discharge Facility	
(1) Required function	P52~P53
(2) Confirmation of items required for measures which should be taken※	P54~60
2.5 Supplementary explanation on safety	P61~63

※ Items required for Measures which should be taken at Tokyo Electric Power Co., Inc.'s Fukushima Daiichi Nuclear Power Station in line with the Designation as the Specified Nuclear Facility (decided by the Nuclear Regulatory Commission on November 7, 2012)

2.2 Application for Approval of Amendment to the Implementation Plan

- Along with the installation of ALPS Treated Water dilution/discharging facilities and related facilities, revisions will be made as follows.
- Table of Contents
- 2.50 New description of ALPS Treated Water dilution/discharge facilities and related facilities, etc.

- II Design and facilities of specified nuclear facilities

2.50 ALPS Treated Water Dilution/Discharge Facilities and Related Facilities

Text

- New description of basic design/basic specifications of ALPS Treated Water dilution/discharge facilities and related facilities.

Attachment 1

- New description of general overview and system outline diagrams

Attachment 2

- New description of specific safety measures for ALPS Treated Water dilution/discharge facilities

Attachment 3

- New description of instructions on structural strength of ALPS Treated Water dilution/discharge facilities

Attachment 4

- New description of items to be confirmed for ALPS Treated Water dilution/discharge facilities and related facilities.

Attachment 5

- New description of instructions on designing water discharge facilities

Attachment 6

- New description of about construction schedule

➤ III Part 3 Safety of Specified Nuclear Facilities (Supplementary Explanation on Safety)

2 Supplementary explanation on the management of radioactive waste, etc.

2.1 Management of radioactive waste, etc.

2.1.2 Management of Radioactive Liquid Waste, etc.

- Added descriptions on the discharge of ALPS Treated Water into the sea.

2.2 Dose assessment

2.2.3 Dose assessment by radioactive liquid waste, etc.

- Added descriptions on the discharge of ALPS Treated Water into the sea.

2.2.6 Action in response to the "Basic Policy on handling of the ALPS Treated Water" of the Fukushima Daiichi Nuclear Power Station of TEPCO Holdings Co., Ltd

New description of measures based on the government policy

2.2 Application for Approval of Amendment to the Implementation Plan

2.5 Contaminated water treatment facilities, etc.

Text

- Addition due to revision of the use of the medium and low concentration tanks in the K4 area for the installation of the ALPS Treated Water dilution/Discharge Facilities

Appendix 12

- Addition due to revision of the use of medium and low concentration tanks in the K4 area for the installation of ALPS Treated Water dilution/Discharge Facilities

2.3 ALPS Treatment Water Dilution/Discharge Facilities

(1) Required Function

- ① The amount of discharge into the sea shall be capable of exceeding the amount of contaminated water generated (the increased amount due to the inflow of groundwater and rainwater).
- ② In order to confirm that the water before dilution/discharge is ALPS Treated Water, it shall be capable of uniformizing the radionuclides concentration in the tanks/tank group and sampling.
- ③ ALPS Treated Water can be diluted with seawater and drained away to discharge facility.
- ④ There is a function to immediately stop discharging ALPS Treated Water into the sea in case an abnormal matter happens.
- ⑤ Have a function to dilute the ALPS Treated Water 100 times or more so that the level of tritium concentration in diluted ALPS Treated Water with seawater is sufficiently below the regulatory concentration limit (60,000Bq/L).

(Implementation Plan: II-2-50-1)

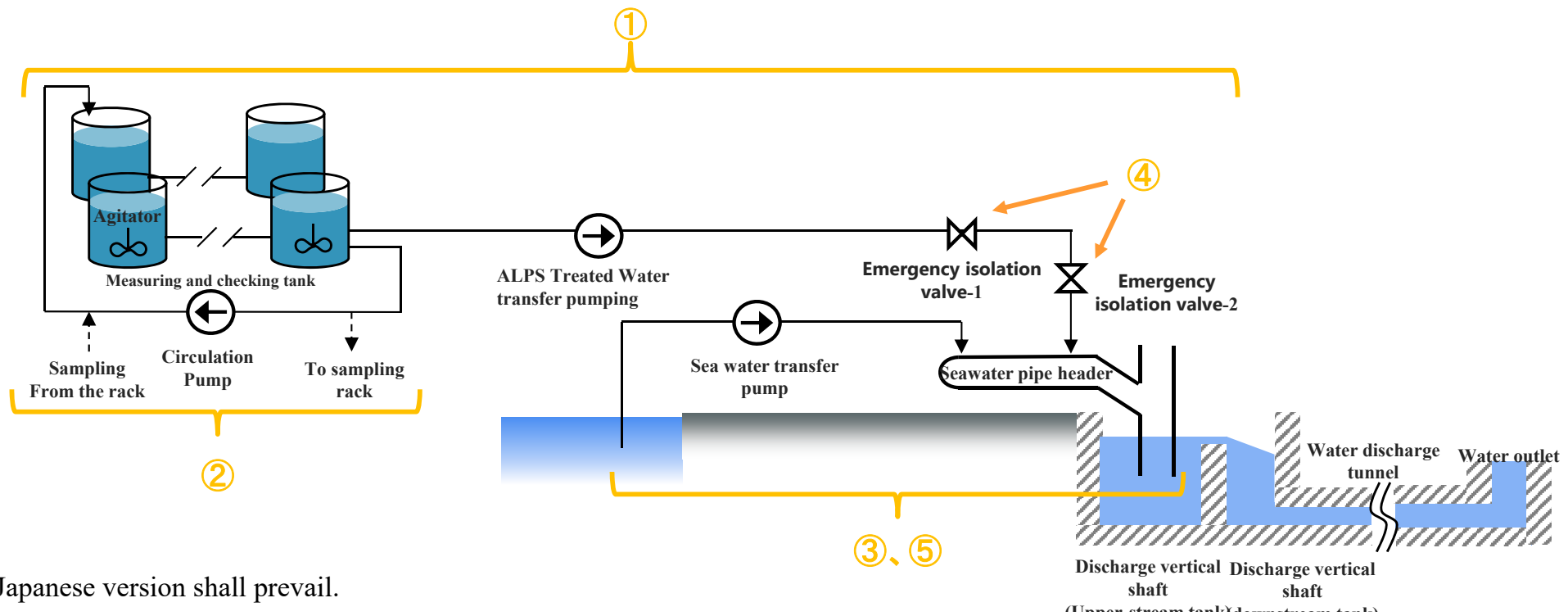

2.3 ALPS Treatment Water Dilute Discharge Facility

(2) Confirmation of items required for measures which should be taken

"9. Treatment, storage, and management of radioactive liquid waste"

In treating radioactive liquid waste such as contaminated water generated in the Facility, taking into account its characteristics, radiation dose in the area surrounding the site shall be reduced as low as reasonably achievable by controlling the waste generation, treating them appropriately to reduce concentration of radioactive materials, securing sufficient capacity for storage and providing shield, preventing leakage and expansion of contamination, etc. In addition, treatment and storage facilities shall be equipped with adequate shielding capability and structures that hamper leak of liquid waste and expansion of contamination so that radioactive materials may not be released into environment through groundwater, water leak, etc.

- Preventing leaks (Implementation plan: II-2-50-Att2-1)
- Circulation pump and transfer pump for ALPS Treated Water shall be manufactured by two-phase stainless steel, etc. which has the strength in corrosion resistance.
- b. Transfer pipes for ALPS Treated Water are manufactured by corrosion resistant polyethylene pipes, and pressure resistant hoses and carbon and stainless-steel pipes are used with enough thickness. The inner surfaces of the main carbon steel pipes are coated with the corrosion resistance. In addition, the parts requiring flexibility shall be rubber expansion joints having corrosion resistance.
- c. The shaft seal part of circulation pump and ALPS Treated Water transfer pump shall have a mechanical seal structure that prevents leakage.

2.3 ALPS Treatment Water Dilute Discharge Facility

(2) Confirmation of items required for measures which should be taken

"9. Treatment, storage, and management of radioactive liquid waste"(continued)

■ Leakage detection and prevention of expansion (Implementation plan: II-2-50-Att2-1)

➤ For circulation pumps, ALPS Treated Water transfer pumps, and emergency isolation valves, a barrier shall be provided around these equipment and a leak detector is provided inside the barrier in order to detect leakage at an early stage and prevent the leakage expansion

➤ The alarm for leakage detection shall be displayed at main control room of the seismic isolation building, etc., and the operational monitoring parameters such as the flow rate shall be checked by the operator and appropriate measures will be taken.

➤ The following measures will be taken for the ALPS Treated Water transfer pipe.

- Regarding transfer pipe laid outdoors, polyethylene pipes and these joints are fusion welded to prevent leakage, and the protective cover will be set on the part of flange joints such as joints between polyethylene pipes and steel pipes to prevent leakage expansion.
- Transfer pipe should be isolated as much as possible from drainage channels and the pipes should be laid in steel boxes, etc. where straddle drainage channels so that the leaked water, if any, shall not contaminate the environment. In addition, sand bags shall be provided so that leaked water does not flow directly into the drainage channel from the steel box end.
- Leakage from transfer pipe shall be detected at an early stage by means of patrol inspection.

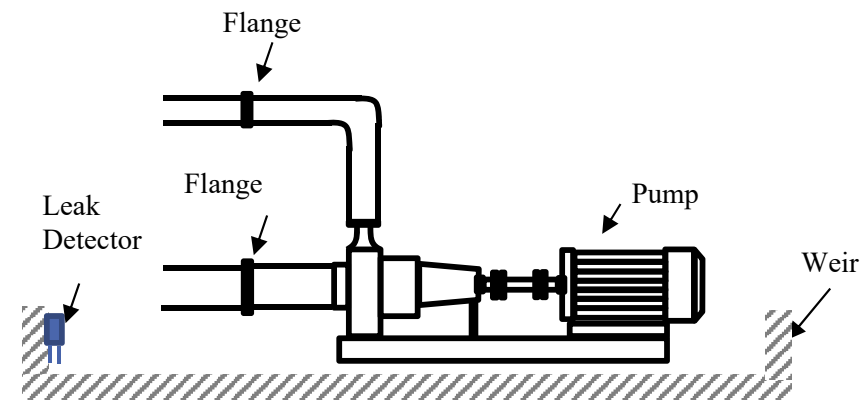

Pump leak detection•
Image of Measures to Prevent Expansion

2.3 ALPS Treatment Water Dilute Discharge Facility

(2) Confirmation of items required for measures which should be taken

"11. Radiation protection, etc. in the area surrounding the site by restricting release of radioactive materials, etc."

○ Radiation dose in the area surrounding the site shall be reduced as low as reasonably achievable, taking appropriate measures to restrict release of radioactive materials from the Specified Nuclear Facility into environment (atmosphere, ocean, etc.).

○ Specifically, effective dose (estimated value taking into account additional releases of radioactive materials from the overall Facility due to rubble and contaminated water, etc. generated after the accident, which are stored in the Facility) along the site boundaries shall be reduced less than 1 mSv/year by March 2013.

■ Dose assessment using radioactive liquid waste (Implementation plan: III-3-2-2-3)

➤ Dose assessment in each facility

Before discharging ALPS Treated Water, it should be confirmed that the Sum of ratios of legally required concentrations, with the exception of H-3 is less than 1 by measurement. In addition, the effluent will be diluted with seawater (100 times or more) to keep the H-3 concentration in the effluent below 1,500Bq/L. Therefore, the effective dose will be 0.035 mSv/year.

< Calculation method >

Dilute the effluent so that the concentration of H-3 in the ALPS Treated Water is below 1,500Bq/L. The ALPS Treated Water, which of the sum of ratios to regulatory concentration limit except H-3 is less than 1 by measurement, will be diluted with seawater (100 times or more). Therefore, the effective dose is conservatively evaluated as follows.

$$\frac{\text{Concentration of H-3}}{\text{Legally required concentration of H-3}} + \text{sum of ratios to regulatory concentration limit, with the exception of H-3} \times \frac{1}{\text{Dilution ratio by seawater}} = \frac{1500}{60000} + 1 \times \frac{1}{100} = 0.035$$

2.3 ALPS Treatment Water Dilute Discharge Facility

(2) Confirmation of items required for measures which should be taken

"11. Radiation protection, etc. in the area surrounding the site by restricting release of radioactive materials, etc." (continued)

- Assessment of the impact of the direct and skyshine rays on the site boundary at the K4 area tank*.

(Implementation Plan: 2.5, Att 12, Att-7)

*Approved on July 4, 2016

➤ Conditions

For the assessment of the impact on the site boundary, the assessment framework is a schematic assessment modeled as a single large cylinder shape with the same volume and height as the tank group.

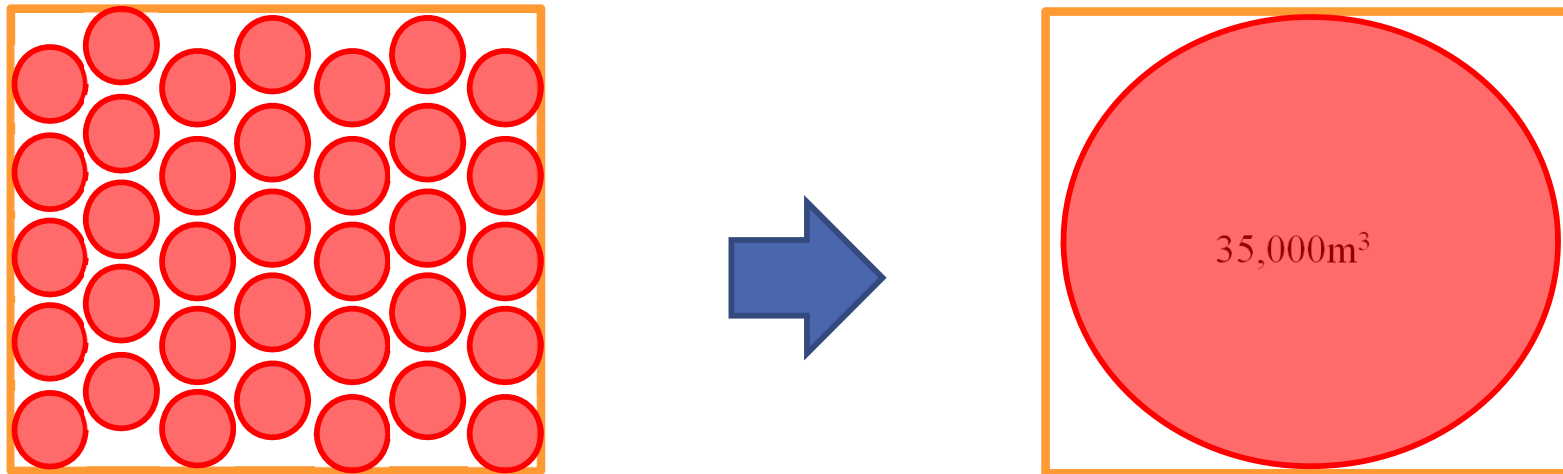

$$1,000\text{m}^3 \times 35 = 35,000\text{m}^3$$

Exposure evaluation by direct and skyshine rays: Less than 0.0001 mSv/year (Nearest assessment point: No.70)
(1.9E-03μSv/year)

2.3 ALPS Treatment Water Dilute Discharge Facility

(2) Confirmation of items required for measures which should be taken

“14. Design Considerations ① Applied codes and standards ”

Design, selection of materials, fabrication and inspection of SSCs with safety function shall conform to those codes and standards which are considered to be appropriate taking into account importance of their safety function, respectively.

- For design, selection of materials, and manufacturing and inspection, reliability shall be ensured by applying Codes for nuclear power generation facilities: rules on design and construction for nuclear power plants (JSME) and Japanese Industrial Standards (JIS) etc.*
 - ※ "JIS G 3454 Carbon steel pipes for pressure service ", " JIS G 3457 Arc welded carbon steel pipes ", " JIS G 3459 Stainless steel pipes ", "JIS G 3468 Large diameter welded stainless steel pipes", and "JWWA K 144 Higher performance polyethylene pipes for water supply" (Implementation Plan: II-2-50-3)
- Within each equipment consisting ALPS Treated Water Dilution/Discharge Facilities, major equipment containing ALPS Treated Water is classified as Class 3, equivalent to waste treatment facilities in the Ministerial Ordinance Establishing Technical Standards for Nuclear Power Generation Facilities. (Implementation Plan: II-2-50-6)
- As for steel pipes, the provisions of Class 3 equipment in JSME S NC1-2012 Nuclear Power Plant Standards Design and Construction Standard (hereafter, "Design and Construction Standards") shall be applied, and Japanese Industrial Standards (JIS) and other Japanese and foreign commercial standards shall also be applied as necessary. (Implementation Plan: II-2-50-6)
- Polyethylene pipes are evaluated to have the structural strength by using the ISO standards or JWWA standards within the applicable range. Pressure resistant hose and expansion joints are evaluated to have the structural strength by using the range of pressure and temperature specified by manufacturer. (Implementation Plan: II-2-50-6)

2.3 ALPS Treatment Water Dilute Discharge Facility

(2) Confirmation of items required for measures which should be taken



"14. Design Considerations ② Design Considerations for Natural Phenomena" (Earthquakes)

SSCs with safety function shall be provided with appropriate seismic categories considering the importance of their safety function and possible safety impact caused by loss of function due to earthquake, and be designed to sufficiently withstand design seismic load considered to be appropriate.

"14. Design Considerations ② Design Considerations for Natural Phenomena (Earthquakes)(continued)

3.1 SEISMIC CLASSIFICATION AND APPLICABLE EARTHQUAKE MOTION FROM A SAFETY PERSPECTIVE IN F

(1) Seismic Class Classification

In the present 1F, it is considered appropriate to classify the following classes according to the degree of radiological effects on the public^{※5} due to the loss of functions of facilities, etc., by referring to the classification of seismic classes in fuel fabrication facilities and use facilities where nuclear fuel materials are handled in a non-sealed manner, rather than the classification of seismic classes of conventional nuclear reactors for practical power generation. In addition, with regard to Class B, in light of the 1F status, it is appropriate to establish a classification with higher seismic resistance than Class B+ for equipment that falls under any of the three conditions listed below.

Class S: $5 \text{ mSv} < \text{public exposure dose around the site}$

B+ class: $50 \text{ } \mu\text{Sv} < \text{public exposure dose around site} \leq 5\text{mSv}$

- Facilities for permanent use
- Equipment that has a significant impact on risk reduction activities and radiation workers' exposure doses in the event of loss of earthquake-resistant functions
- Equipment ^{※6} that may have a ripple effect on S-class facilities

Class B: $50 \text{ } \mu\text{Sv} < \text{public exposure dose around site} \leq 5\text{mSv}$

Class C: $\text{Public exposure dose around the site} \leq 50\mu\text{Sv}$

※5: If it is difficult to show the validity of the impact assessment due to the release of liquid radioactive materials during the seismic class classification, it should be excluded from the impact assessment, and then design facilities that contain liquids, etc., that have a large impact on the outside due to their release, such as liquids before treatment with a multinuclide removal facility, etc., so that they will not leak into the ocean even if the function is lost. In addition, it is desirable to adopt the above-mentioned design measures for equipment that contains liquids that have relatively little impact on the outside due to discharge, such as liquids after processing with a multinuclide removal facility, etc., but in cases where it is difficult, measures should be taken to mitigate the effects of releasing such liquids by temporary hoses, for example, in the event of a loss of function.

※6: At the beginning of the accident, facilities with a ripple effect on the S-class containment vessel and spent fuel pool have been required to maintain their functions against Ss600 in addition to the seismic force applied to Class B. However, unlike conventional nuclear power reactor facilities, the present 1F has a lower potential radiation risk due to the progression of the decay of radionuclides in spent fuel and debris. Therefore, in consideration of the degree of the impact on the outside that should be kept in mind, facilities with a ripple effect on the facilities of Class S, such as fuel extraction facilities, shall be classified as Class B+.

2.3 ALPS Treated Water Dilution/Discharge Facilities

(2) Confirmation of conformity with matters for which measures should be taken

"14. Design Considerations ② Design Considerations for Natural Phenomena" (Earthquakes) (continued)

- Following the presentation of the "Concept of Seismic Design" by the Nuclear Regulation Authority (July 7, 2021), the classification shall be based on the "Degree of Radiation Impacts on the Public Due to Loss of Function of Facilities" referring to the concept of Seismic Classification of Nuclear Fuel Facilities.
- As a result of the assessment of radiation impacts and functional countermeasures, [the seismic class classification is considered to be "C class"](#).

[Possible loss of function of facilities]

- Damage to connecting pipes due to sliding of tanks, which are for measuring and verification, caused by earthquakes.
Leakage of ALPS Treated Water from damaged parts.

→ Result of assessment of radiation impacts on the public due to loss of function of tanks, which are for measuring and verification: [<1μSv/year](#)

Result of assessment of radiological impacts on the Public due to airborne migration of leaked water: [0.4μSv](#)

[Flexible responses, etc.]

- In the event of an earthquake of intensity 5-lower or above, priority should be given to checking the site, and if a leakage is detected, the connecting valve shall be closed immediately.
- Foundation perimeter weirs shall be installed to prevent significant leakage of stored water from the site due to damage to the Class C tanks by earthquakes. The weirs shall be of Class B seismic strength and shall have the necessary strength to withstand the horizontal design seismic intensity required for Class B buildings.
- If the stored water leaks and accumulates in the perimeter weirs of the foundation, the leaked water should be collected using a temporary pump or high-pressure suction vehicle. The collected leaked water should be drained into uncontaminated tanks and buildings.

[Supplementary material] Exposure Evaluation by Direct and skyshine Ray **TEPCO**

[Degree of Radiation Impacts on the Public]

- The results of assessment of the radiation impacts on the public due to the loss of the function of the measurement and verification tanks[※] are as follows.

※ The assessment here includes the five multi-nuclides treated water storage tanks in Chapter 2.5

➤ Conditions

Radiation impacts on the public in the event such as damages to the connecting pipes due to sliding of the tanks caused by an earthquake, leakage of treated ALPS Treated Water from the damaged parts, leakage of all the water contained in the tanks to the outside of the tanks (assuming that the tanks continue to exist in the form of a single large cylinder with the same volume and height as the tank group).

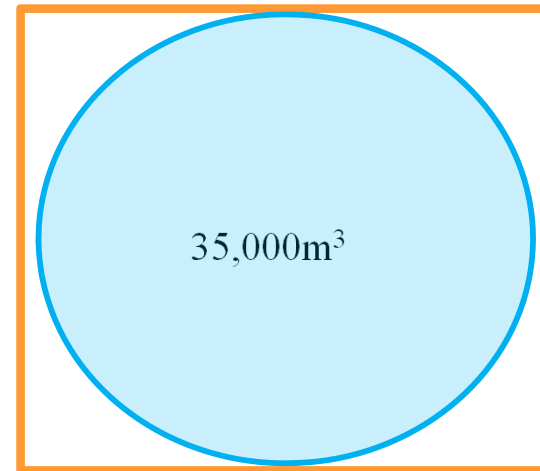
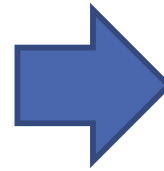
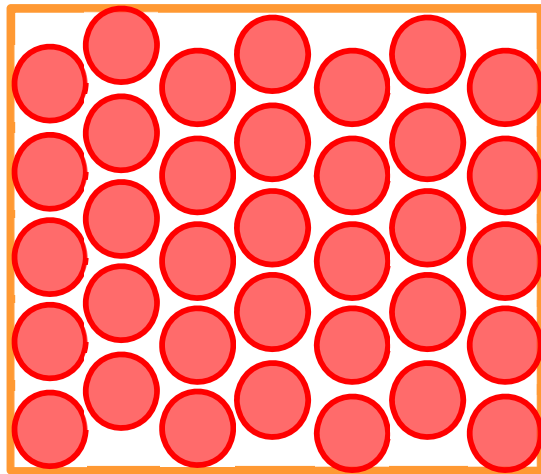

$$1,000\text{m}^3 \times 35 = 35,000\text{m}^3$$

Exposure Evaluation by direct and sky-shine radiations: $< 1 \mu\text{Sv}/\text{year}$ (Nearest assessment point: No. 70)

※ As an approximation, it is assumed that the impact on the site boundary would increase by about 1.25 to 2.0 times if the tanks are no longer shielded. Even if a conservative calculation of 2.0 times is made, the impact on the nearest point is insignificant.

[Degree of Radiation Effects on the Public]

- The results of assessing the radiation impacts on the public due to the loss of the function of the measurement and verification tanks^{※1} are as follows.

※1: The assessment here includes the five multinuclides treated water storage tanks in Chapter 2.5

➤ Conditions

Damage to connecting pipes due to the sliding of the tanks caused by the earthquake, ALPS Treated Water leakage from the damaged parts, spreads of water over the entire storable area in the tank weir and diffusion of vapor from the water containing tritium. Internal exposure from tritium ingested by respiration by people living at the site boundary (the nearest assessment point)

(Radiation effects assumption of collecting water within^{※2} two weeks)

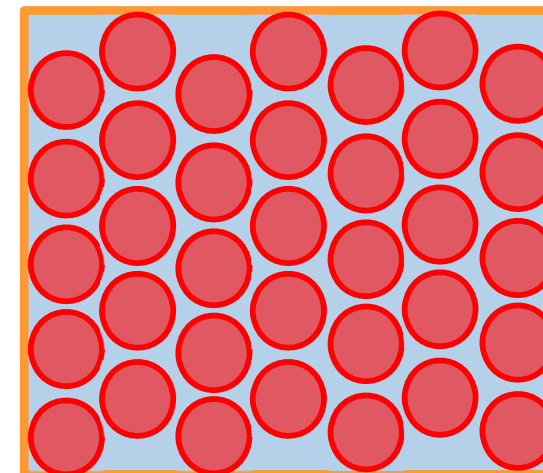
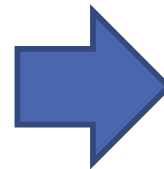
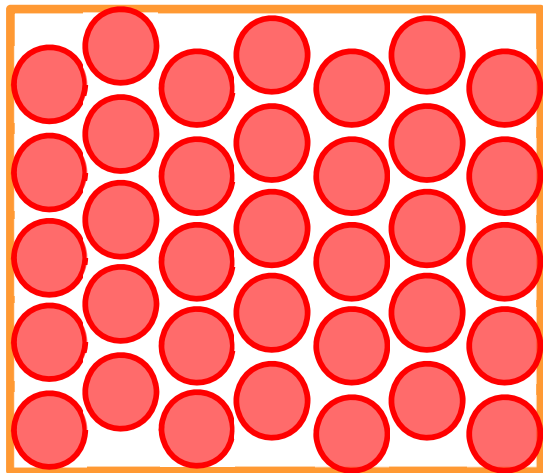

Available storage area (2, 201m²)

Exposure Evaluation by airborne migration: $0.4\mu\text{Sv}$ (Nearest evaluation point: No. 70)

※2: If a 30m³ /h temporary pump is used for 24 hours collection, it would take about three days. Taking into account the preparation work, it is estimated to take about one week, but it was set to be two weeks conservatively.

2.3 ALPS Treated Water Dilution/Discharge Facilities

(2) Confirmation of conformity with matters for which measures should be taken

"14. Design Considerations ② Design Considerations for Natural Phenomena" (Non-Earthquake Natural Phenomena)

- Buildings, systems and devices with safety functions shall be designed so that the safety of the facilities will not be impaired by expected natural phenomena other than earthquakes (tsunamis, heavy rainfall, typhoons, tornadoes, etc.). Buildings, systems and facilities with a particularly high level of importance of safety functions shall be designed in consideration of the conditions that are considered to be the most severe of the expected natural phenomena, or the case where the accident load is appropriately combined with the natural force.

■ Tsunami (Implementation Plan: II-2-50-5)

- Some equipment installed in the Measurement/Confirmation Facilities and Transfer Facility of the ALPS Treated Water Dilution/Discharge Facilities, excluding the Dilution Facility, should be constructed on the ground at about 33.5m Tokyo Bay mean tidal level (T.P.) or higher where a tsunami is expected to be unreachable.
- In addition, when a large tsunami warning is issued, Both of Transfer and Dilution Facilities will be stopped to avoid the damage risk caused by tsunami.

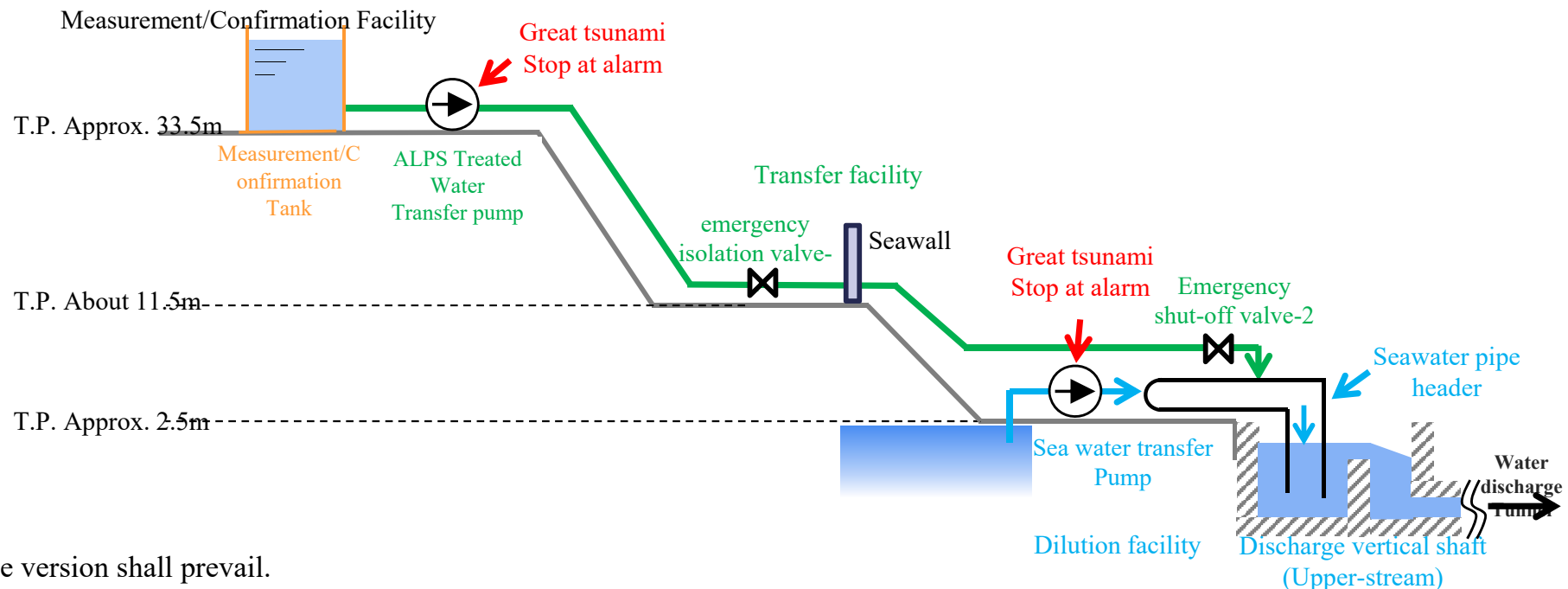

2.3 ALPS Treated Water Dilution/Discharge Facilities

(2) Confirmation of conformity with matters for which measures should be taken

"14. Design Considerations ② Design Considerations for Natural Phenomena" (Non-Earthquake Natural Phenomena) (Continued)

- Snow cover (Implementation plan: II-2-50-5)
 - To prevent damage to facilities due to snow cover, buildings shall be designed with snow cover loads based on the Enforcement Order of the Building Standards Law and Detailed Enforcement Regulations of Fukushima Prefectural Building Standards Law.
- Lightning strikes (Implementation plan: II-2-50-5)
 - Dynamic equipment and electrical components shall be prevented from damage due to lightning strikes by equipment grounding.
- Tornado (Implementation plan: II-2-50-5)
 - If the possibility of tornadoes is anticipated, the equipment will be stopped with consideration of the damage risk due to tornadoes.
- Typhoon (Strong Wind) (Implementation plan: II-2-50-5)
 - Within ALPS Treated Water Dilution/Discharge Facilities, the circulation pump and ALPS treatment water transfer pump shall be installed in the steel structured building which is unlikely to be damaged by the typhoon (strong wind). Other mechanical items such as transfer piping installed outdoors shall be designed to prevent them from falling over by fixing them with foundation bolts.
 - Within ALPS Treated Water Dilution/Discharge Facilities, electric components such as control panels etc. shall be installed in the lightweight steel frame building for ALPS electrical panel and cubicles room, which is unlikely to be damaged by a typhoon (strong wind).

2.3 ALPS Treated Water Dilution/Discharge Facilities

(2) Confirmation of conformity with matters for which measures should be taken

"14. Design Considerations ④ Design Considerations for Fires"

- To be designed so that the safety of the facility is not impaired by fire, by appropriately combining measures for fire prevention, fire detection and extinguishment, and mitigation of the impact of fire.
- Fire (Implementation Plan: II-2-50-5)
 - ALPS Treated Water Dilution/Discharge Facilities shall be applied for incombustible or flame retardant as practically as feasible to prevent fire.
 - In this facility, patrol inspections are conducted to detect fire as soon as possible and design should be considered to detect fire with fire detection at circulation pumps, ALPS Treated Water transfer pumps, and areas around electrical panels and cubicles. Furthermore, fire extinguishers shall be installed near each facility to enable initial firefighting and to facilitate firefighting activities.
 - In addition, guidance signs shall be installed in the building for guidance during evacuation.

2.3 ALPS Treated Water Dilution/Discharge Facilities

(2) Confirmation of conformity with matters for which measures should be taken

"14. Design Considerations ⑤ Design Considerations for Environmental Conditions"

- Structures, systems and components with safety functions shall be designed to meet all environmental conditions, including ageing events. In particular, measures should be taken that fully take into account the soundness evaluation of structures damaged by accidents, earthquakes, etc.

■ Freezing (Implementation Plan: II-2-50- Att 2-2)

- When the water transfer is stopped, the outdoor laying polyethylene pipes may break due to freezing. Therefore, insulation materials are installed to the pipes to prevent freezing. The rigid polyurethanes and etc., are installed for insulation materials which have high airtightness and thermal insulation properties and sufficient thickness will be required to ensure from freezing.

■ Ultraviolet rays (Implementation plan: II-2-50- Att 2-2)

- In order to prevent deterioration due to ultraviolet rays, insulation materials which have carbon black with anti-ultraviolet rays are installed to outdoor polyethylene pipes. Or, to install insulation materials which does not have carbon black with anti-ultraviolet rays, coating materials with carbon black or steel plates with hardly deteriorated from ultraviolet rays are installed.

■ Thermal deterioration (Implementation plan: II-2-50- Att 2-2)

- Thermal deterioration is concerned for polyethylene pipes. However, the possibility of thermal deterioration of the polyethylene pipes is sufficiently low. It is because the temperature of ALPS Treated Water is close to the normal temperature.

2.3 ALPS Treated Water Dilution/Discharge Facilities

(2) Confirmation of conformity with matters for which measures should be taken



"14. Design Considerations ⑦ Design Considerations for Operator Operation"

- The design shall have appropriate measures to prevent operators from errors.
- Consideration for Preventing Improper Operation (Implementation plan: II-2-50-3)
 - The facility shall be designed to require double-action for critical operations such as discharge and transfer in order to prevent operational error and misjudgment. The operation related to the discharge permission shall be designed to require the key switch operation, in addition to the double-action.

[Supplementary material] Efforts to Prevent Human Errors (1/4)

- One tank group consists of 10 sample tanks and the tank groups are divided into three to rotate their tasks of three different processes: the acceptance process, the Measurement/Confirmation process, and the release process.
- In order to prevent human error during operation (mistakes caused by lack of recognition like mix-up a receiving tank group and the discharge tank group, etc.), interlocks are provided for the operation of the tank group, such as checking the status of the tank group and valves in each work process.
- This system is designed to prevent the mixing of water between tank groups and the release of ALPS Treated Water prior to analysis.
(Refer to the following pages for specific interlocks for each process.)

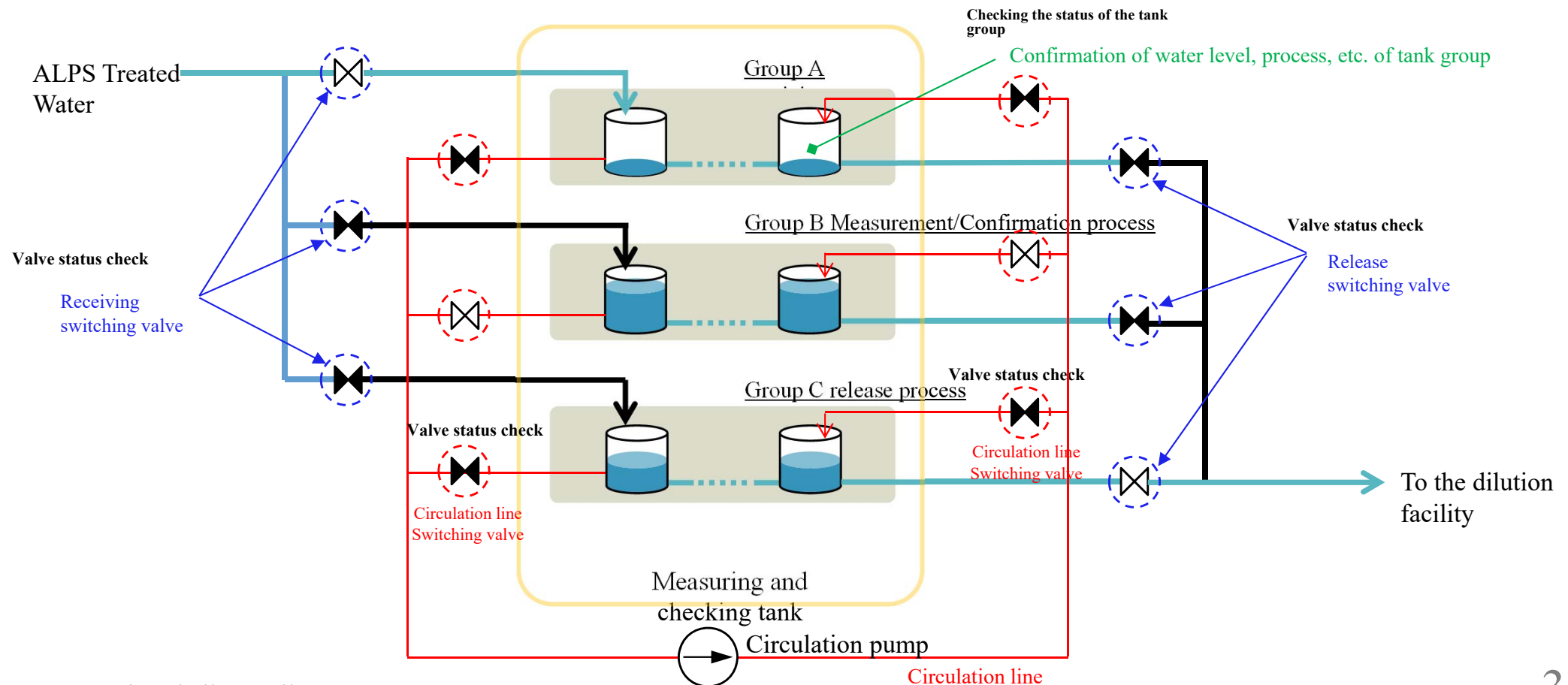

[Supplementary material] Efforts to Prevent Human Errors (2/4)



Acceptance operation

(Example) When acceptance operation of group A is performed

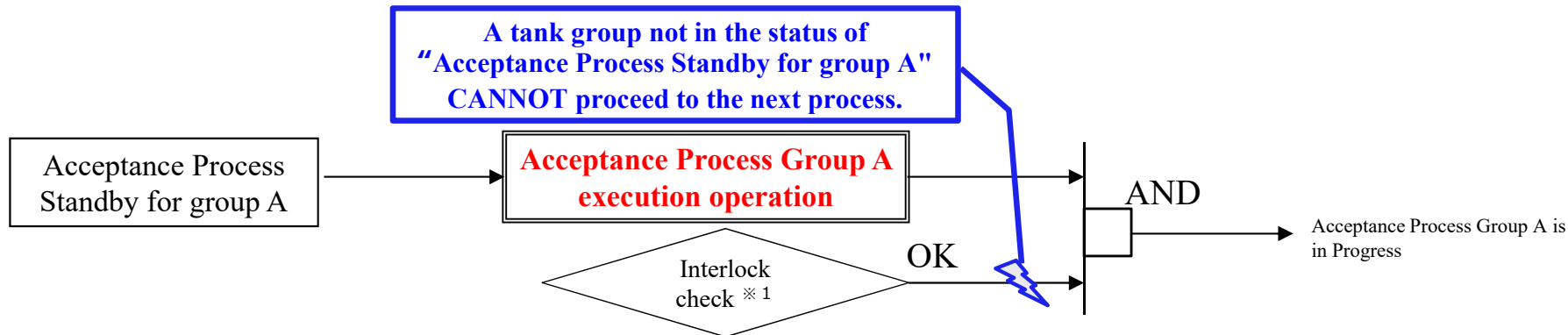

※ 1 Interlock check

- ✓ Group A must be in the status of "Standby for group A acceptance process" (below "high water level")
⇒ Check the status of the target tank group.
- ✓ Confirm that group B and C are not in the receiving process ⇒ Check the status of other tank groups
- ✓ Confirm that the receiving switch valves of groups B and C are fully closed ⇒ Check the valve status (Physical inflow prevention to other tank groups)

(Example) When the status of the tank group is not in the "acceptance process standby" (that means it is in the "measurement /confirmation process" or "release process"), even if an operator mistakenly performs on a incorrect [Group B acceptance process execution operation], the process cannot proceed to the "acceptance process".

(The tank group has the status of "receiving process standby", only after the completion of the "discharging process" of the certain tank group.)

[Supplementary material] Efforts to Prevent Human Errors (3/4)



Measurement and Confirmation Operations

(Example) When performing measurement/confirmation operation of group A

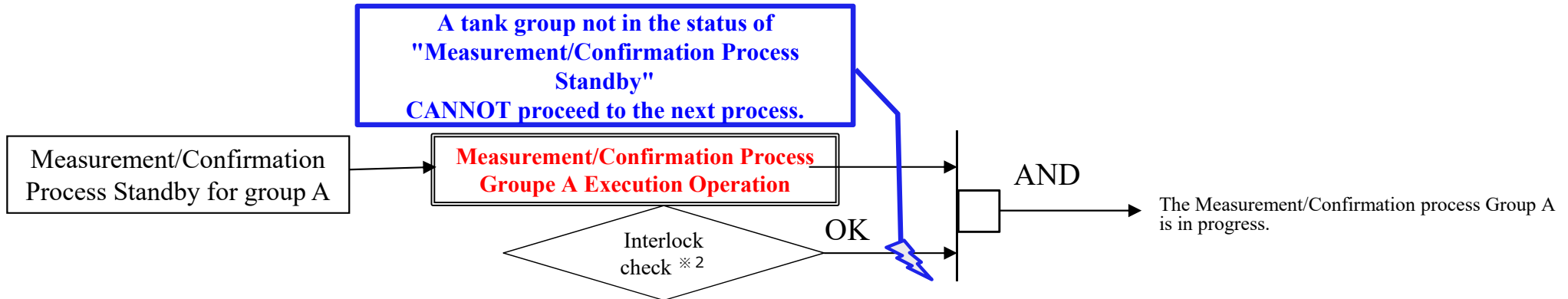

※2 Interlock check

- ✓ Group A must be in the status of “Measurement/Confirmation Process Standby” (below “high water level for circulation”) ⇒ Check the status of the target tank group.
- ✓ Check that groups B and C are not in the status of “Measurement/Confirmation Process Standby” ⇒ Check the status of other tank groups
- ✓ Circulation line switching valves of groups B and C are fully closed ⇒ Check valve status (Physical inflow prevention to other tank groups)

(Example) If the status of the tank group is not in the status of “measurement/confirmation process standby” (that means in the status of “acceptance process” and “release process”), even if an operator mistakenly try to perform on a [Group B Measurement/confirmation process execution operation] , the process cannot proceed to the “measurement/confirmation process execution operation.”

[Supplementary material] Efforts to Prevent Human Errors (4/4)



Release operation

(Example) When releasing group A

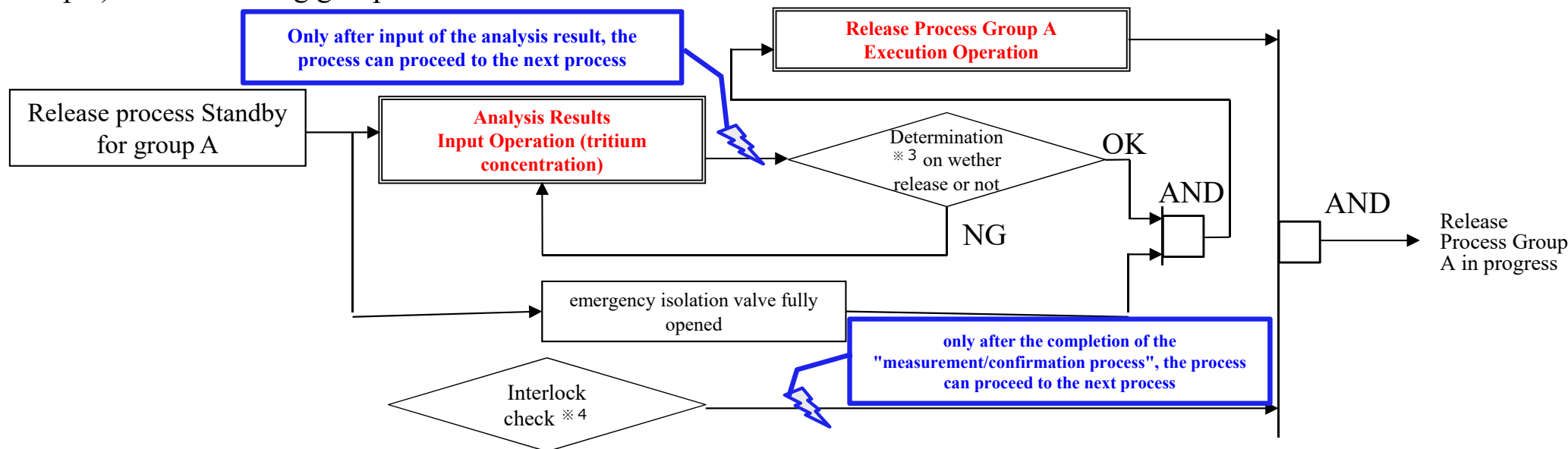

※3 Determination on whether release or not

- ✓ Confirm that the diluted seawater volume (number of seawater transfer pumps operated) can be diluted to the set concentration.

※4 Interlock check

- ✓ Group A should be waiting for release process
(The "Measurement/Confirmation Process" of the previous process has been completed) ⇒ Check that any process is not skipped.)
- ✓ Confirm that the group A receiving selector valve is fully closed ⇒ Prevent water from other sources from flowing into group A.
- ✓ Confirm the discharge selector valves of groups B and C are "fully closed" ⇒ Prevent the discharge of water from the tank group that is not in the discharge process.
- ✓ Check the status of the Seawater transfer pumps in operation ⇒ Prevents ALPS Treated Water from being released undiluted
- ✓ The key switch must be in the status of "release enabled" ⇒ Prevention of incorrect operation by changing the operation method

(Example 1) Even if an operator mistakenly try to perform on [Release Process Group A Execution Operation] without the completion of the analysis of ALPS Treated Water, the process cannot proceed to the next step unless the analysis results are input.

(Example 2) Even if an operator mistakenly try to perform on [Release Process Group B Execution Operation], the process cannot proceed to the "release process", unless the previous process of the "measurement/confirmation process" is completed.

2.3 ALPS Treated Water Dilution/Discharge Facilities

(2) Confirmation of conformity with matters for which measures should be taken

"14. Design Considerations ⑧ Design Considerations for Reliability" (Structural Strength Assessment)

- Structures, systems and components with safety and monitoring functions shall be designed to ensure and maintain sufficient reliability.

■ Assessment Methods (Implementation Plan: II-2-50-Att 3-5)

- Confirm that the minimum thickness of the steel pipe satisfies the required thickness required by "Design and Construction Standard PPD-3411 Equation (PPD-1.3)" (hereinafter ①) or "Table PPD-3411-1 of Design and Construction Standard PPD-3411 (3)" (hereinafter ②).
- The required thickness of the pipe shall be one of the following values, whichever is larger: (① or ②):
 - Pipe receiving pressure on the inner surface

$$\text{Pipe thickness required for calculation : } t = \frac{PD_0}{2S\eta + 0.8P} \cdot \cdot \cdot \text{①}$$

P : Maximum design pressure (MPa)

D_0 : Outer diameter of pipe (mm)

S : Allowable tensile stress of material at maximum operating temperature (MPa)

η : Efficiency of the expansion joint

- Minimum thickness required for design and construction standards for carbon steel pipes: t_r : ②
⇒ Values obtained from "Table PPD-3411-1" of Design/Construction Standards PPD-3411 (3)

2.3 ALPS Treated Water Dilution/Discharge Facilities

(2) Confirmation of conformity with matters for which measures should be taken

"14. Design Considerations ⑧ Design Considerations for Reliability" (Structural Strength Assessment) (Continued)

■ Assessment Results (Implementation Plan: II-2-50-Att 3-5)

- Assessment results are given in Table -1. It is assessed that these satisfy the required thickness and have sufficient structural strength.

Table-1 Assessment results of structural strength of main pipe (steel pipes)

Equipment to be assessed※	Outer diameter (mm)	Material	Maximum design pressure (MPa)	Maximum operating temp (°C)	Required thickness (mm)	Minimum thickness (mm)
Pipe ①	216.3	SUS316LTP	0.49	40	0.46	5.68
Pipe ②	139.8	SUS316LTP	0.98	40	0.59	4.37
Pipe ③	165.2	SUS316LTP	0.98	40	0.69	4.37
Pipe ④	216.3	SUS316LTP	0.98	40	0.91	5.68
Pipe ⑤	165.2	SUS316LTP	0.49	40	0.35	4.37
Pipe ⑥	114.3	SUS316LTP	0.49	40	0.24	3.50
Pipe ⑦	76.3	SUS316LTP	0.98	40	0.32	3.00
Pipe ⑧	114.3	SUS316LTP	0.98	40	0.48	3.50
Pipe ⑨	114.3	STPG370	0.98	40	3.40	5.25
Pipe ⑩	914.4	STPY400	0.60	40	4.56	11.43
Pipe ⑪	2235.2	SM400B	0.60	40	11.14	15.00
Pipe ⑫	1828.8	SM400B	0.60	40	9.11	12.00

※Refer to reference material for piping No.

2.3 ALPS Treated Water Dilution/Discharge Facilities

(2) Confirmation of conformity with matters for which measures should be taken



"14. Design Considerations ⑧ Design Considerations for Reliability" (Handling of Non-Metallic Materials Not Described in JSME)

- Structures, systems and components with safety and monitoring functions shall be designed to ensure and maintain sufficient reliability.

- Polyethylene tubes conforming to ISO or JWWA standards shall be evaluated as having structural strength when used within the scope of application. Pressure-resistant hoses and expansion joints shall be evaluated to have structural strength when used at pressures and temperatures within the manufacturer's specifications.
(Implementation Plan: II-2-50-6)

2.3 ALPS Treated Water Dilution/Discharge Facilities

(2) Confirmation of conformity with matters for which measures should be taken

"14. Design Considerations ⑨ Design Considerations for Inspectability"

- Structures, systems and components having safety functions shall be designed so that their functions can be inspected in an appropriate manner in order to confirm their soundness and capability.
- In the installation of the equipment, it is designed considering future maintenance.
- With regard to the management of facility maintenance, a long-term inspection plan shall be prepared and inspections shall be carried out based on the inspection plan.
- The equipment to be installed this time is mainly a tank, piping, pumps, etc. in accordance with the targets for inspection before use, and the consideration for the typical inspection is as follows.
 - Tank
 - Appearance and internal inspection
An inspection port is installed in the tank for inspection, and the inside is designed to be inspected.
 - Pipe
 - Appearance and flange inspection
It is designed so that replacement of the gasket of the flange (seal) can be inspected.
 - Pump
 - Appearance, disassembly and inspection, function check
It is designed so that disassembly and inspection can be carried out.
 - Water Discharge Vertical Shaft (Upper-stream storage)
 - Appearance and internal inspection
An inspection port is installed in a water discharge vertical shaft (Upper-stream storage) for inspection, and the inside is designed to be inspected.

2.3 ALPS Treated Water Dilution/Discharge Facilities

(2) Confirmation of conformity with matters for which measures should be taken

“15. Other Measures to Be Taken” (Measurement/Confirmation Facility to Unify the Concentration of Radioactive Materials)

- In addition to the above, take measures when deemed necessary for the prevention of disasters, etc.
- In the measurement/confirmation equipment, the concentration of radioactive materials in the tank groups shall be almost uniformized by circulating the water in the tank groups with a circulation pump before sampling so that representative samples can be obtained. The capacity for circulation volume will be secured greater than the capacity of the tank group based on the "Guidelines concerning measurement of radioactive materials discharged from light-water type nuclear reactor for power generation". In addition, Agitation equipment will be installed in each tank to promote uniformization.

(Implementation plan: II-2-50-Att 2-3)

- A demonstration test will be conducted before the start of operation (see the figure below) to check the performance of the equipment.

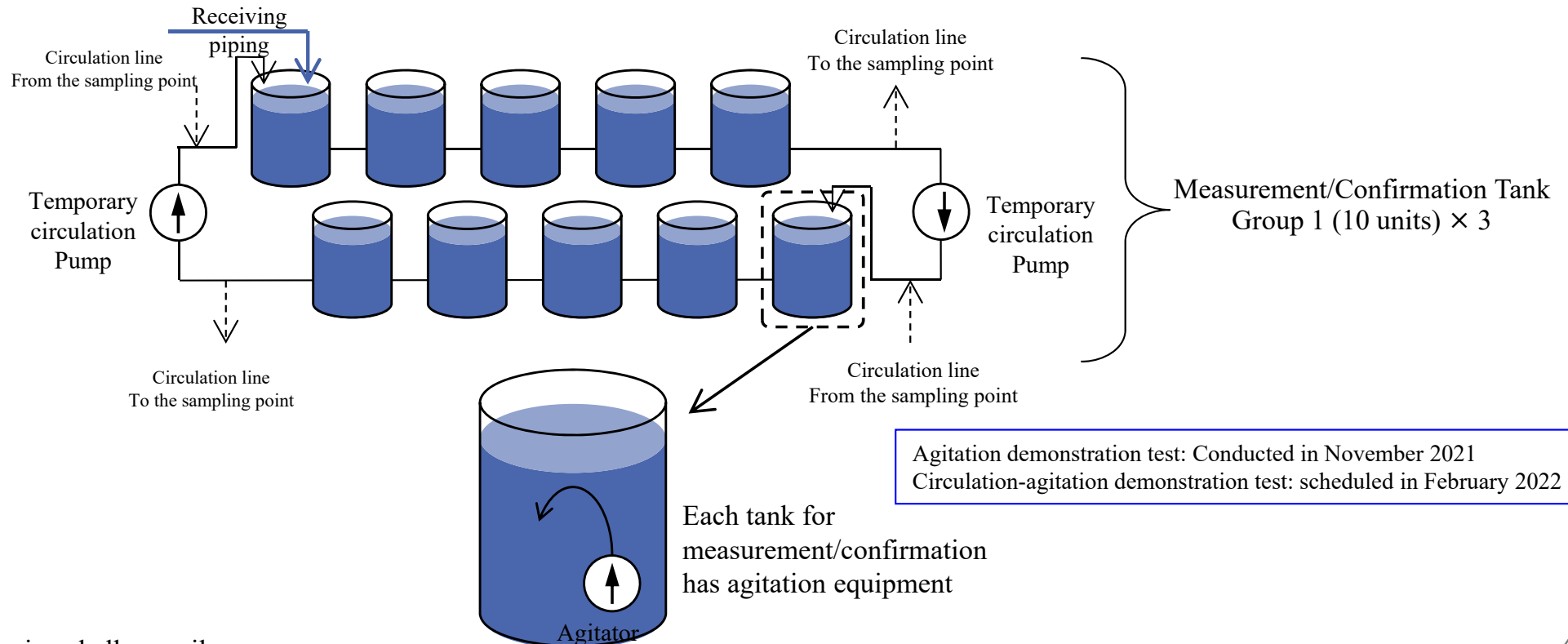

[Supplementary material] Agitation Demonstration Test (1/3)

- In the agitation demonstration test conducted this time, a agitation equipment is newly installed at the bottom of the tank. The operation of the agitation equipment is checked and the agitation effect is examined through adding reagents into the tank.
- In February 2022, a circulation demonstration test, which focuses eight nuclides ※¹ and the same reagents, scheduled in K4-B group.

※¹:Seven major nuclides (Cs-134,Cs-137,Sr-90,I-129,Ru-106,Co-60,Sb-125) and tritium

Date of implementation	23 November, 2021
Examination time	Approx. 8 hours
Sampling	Approx. every 30 min, 9 times including before the test
Volume collected	1 liter each (3 samples taken (at the top (11.6m), middle (7.6m), and bottom (2.6) of the tank)
Object of analysis	Reagent ※ ²
Target tank	K4-A5

※²:For tritium in the sample tank, since there is no variance in concentration in the tank, the reagent (sodium tertiary phosphate ※³) not present in the tank was added into the tank, and the concentration distribution was confirmed.

※³:As the amount of sodium tertiary phosphate input is 1/100 of the effluent standard (phosphorus content "average of 8ppm per day") specified by the Fukushima Prefecture ordinance, there is no effect on the environment.

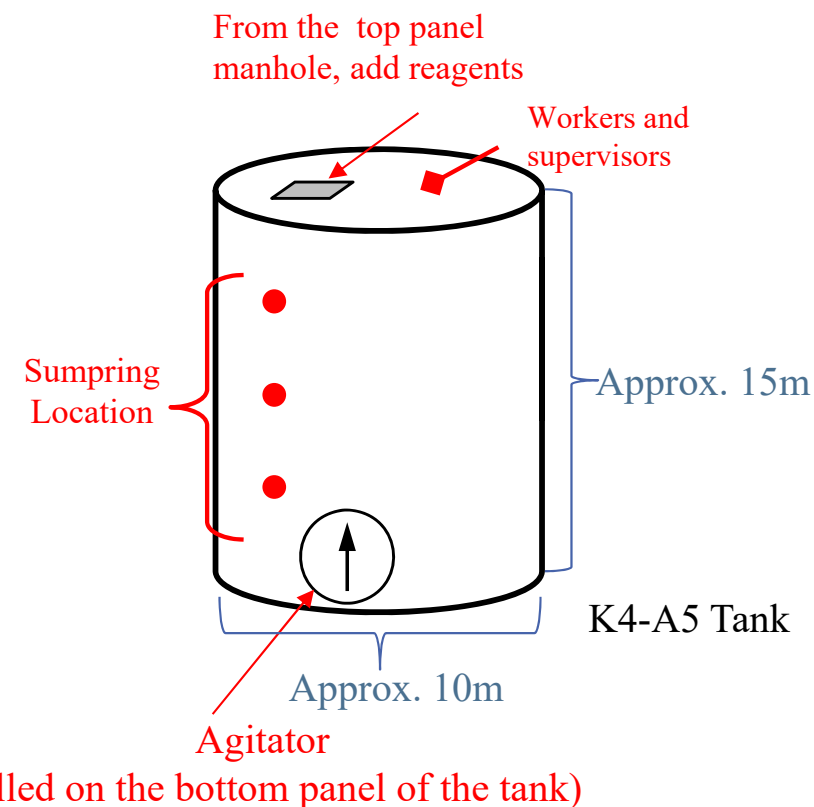

[Supplementary material] Agitation Demonstration Test (2/3)



[Agitation test]

Demonstration test period: November 23, 2021

Test time : 5 hours 25 minutes (stirring time 4 hours)

Sampling: Approximately every 30 minutes

Collection quantity: 1L each (3 sampling points: tank top (11.6m), middle (7.6m) and bottom (2.6m))

Analyzed: Phosphate ※ (confirm differences with theoretical mean of 80ppb)

Target tank: K4-A5

[Test method]

8:00 Sampling (first time) before stirring test

8:30 Add sodium tertiary phosphate solution (about 2.6L)

9:00 Start agitation mixer

9:30 Stop agitation mixer (stirring time: 30 minutes)

9:30~ Sampling (2nd time) after checking stability of tank water surface

After that, the agitator mixer is repeatedly started and stopped,

A total of nine samples are scheduled to be sampled (end time: around 16:30)

After completion, submit a total of 27 sample bottles to the No. 5/6 Hot Lab.

- ※ • A tracer (sodium tertiary phosphate ※²) was charged into the tank, and the concentration profile was confirmed.
- The amount of sodium tertiary phosphate input is about 1/100 of the standard stipulated in the Fukushima Prefectural Ordinance, so there is no influence on the environment.
- Concentrations are determined by absorbance method.



Photograph of agitator



Tank water surface when agitator is running (photographed at T/R)



Sampling of water on the day of agitation test

[Supplementary material] Agitation Demonstration test(3/3)



- The concentration of about 2.6L of sodium tertiary phosphate added into the tank is about 30g/L, and the theoretical concentration is about 80ppb when diluted with about a 970m³ of water contained in the tank.
- At a stage in which stirring by the agitation equipment was performed for 30 minutes, the concentration of the sodium tertiary phosphate contained in the sample was stable at a value around 80ppb, and a stirring effect by the agitation equipment was observed (with respect to a standard sample of 80ppb, a standard deviation σ of 3.0ppb)

Results of agitation test analysis (11/23)

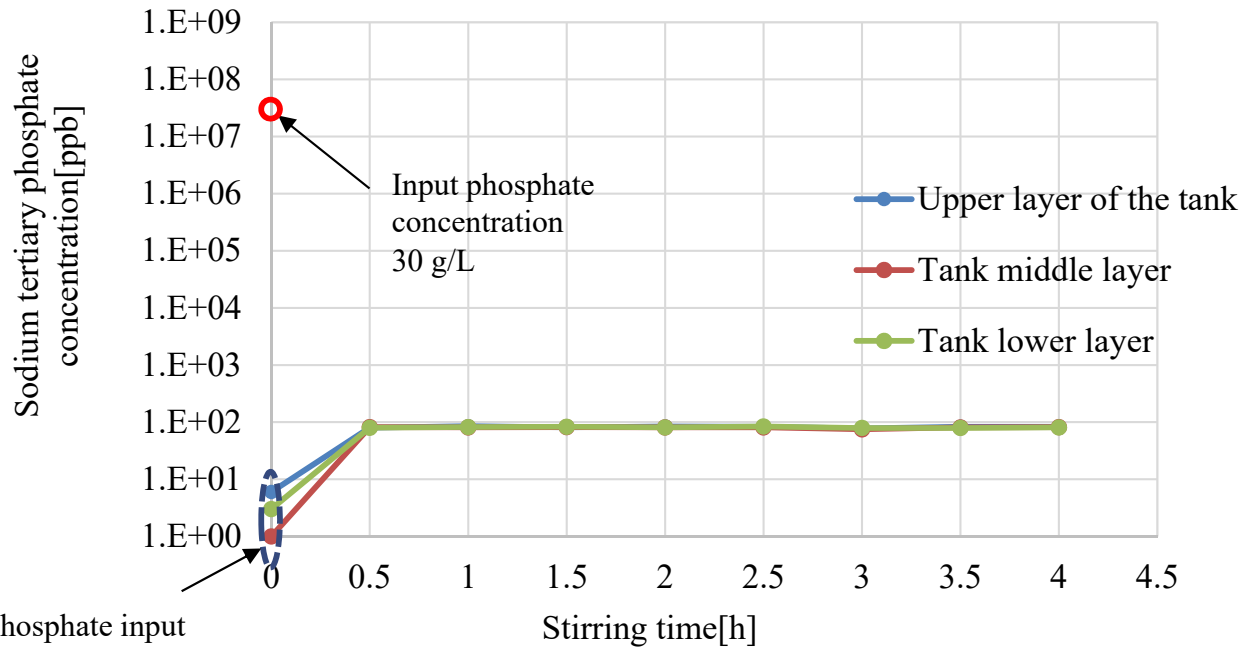

	1st time (0 h)	2nd time (0.5 h)	3rd time (1.0 h)	4th time (1.5 h)	5th time (2.0 h)	6th time (2.5 h)	7th time (3.0 h)	8th time (3.5 h)	9th time (4.0 h)
Upper layer	6	80	85	81	84	83	78	83	83
Middle layer	1	82	81	82	81	81	75	81	82
Lower layer	3	80	82	83	81	84	79	79	81

2.3 ALPS Treated Water Dilution/Discharge Facilities

(2) Confirmation of conformity with matters for which measures should be taken

"15. Other measures to be taken" (dilution and mixing of ALPS Treated Water with seawater)

- In addition to the above, take measures when deemed necessary for the prevention of disasters, etc.

- The ALPS Treated Water is diluted by injecting Treated Water into the seawater pipe header where the dilution seawater flows. The injected ALPS Treated Water flows down in the seawater pipe and mixes with the surrounding seawater and the concentration of radioactive materials will decrease.

(Implementation plan: II-2-50-Att 2-3)

- From the analytical results, it was concluded that the injected water was thinned to more than 100 times (430 times) even in the maximum concentration area in the seawater piping toward the discharge vertical shaft (see the next page for details).

(Implementation plan: II-2-50-Att 2-9)

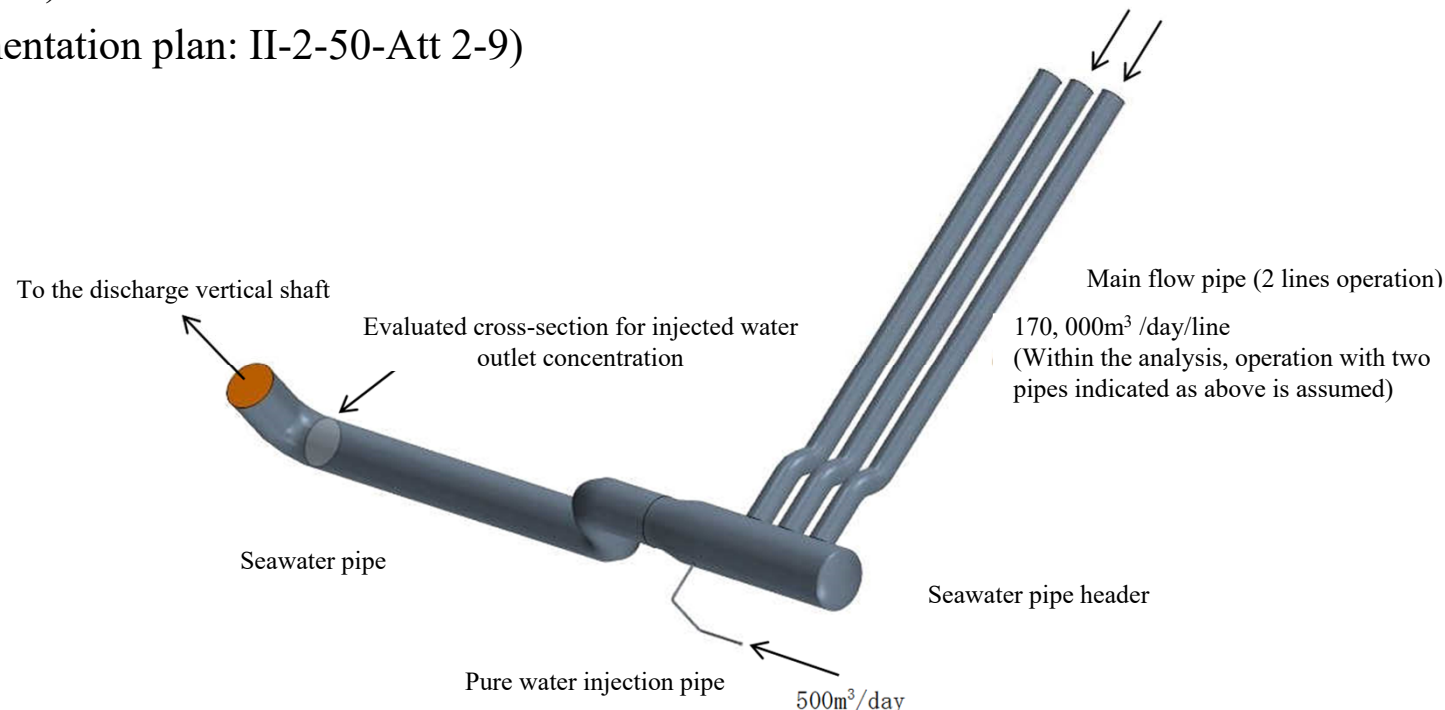
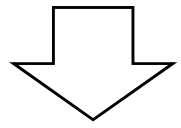

Figure-1 Analytical Model



[Supplementary material] Analysis results of diffusion mixing in seawater piping (1/2)

Diffusion mix analysis in seawater pipes when ALPS processed water flow is 500m³ per day and seawater flow rate is 340,000 m³ per day



Confirm that it is diluted to 5% or less (1/20 or less) in the vicinity of the injection pipe.

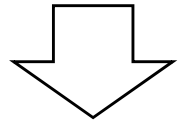

In the figure on the right, since the dilution situation of 5% or less cannot be shown, a logarithmic axis is reposted on the next slide.

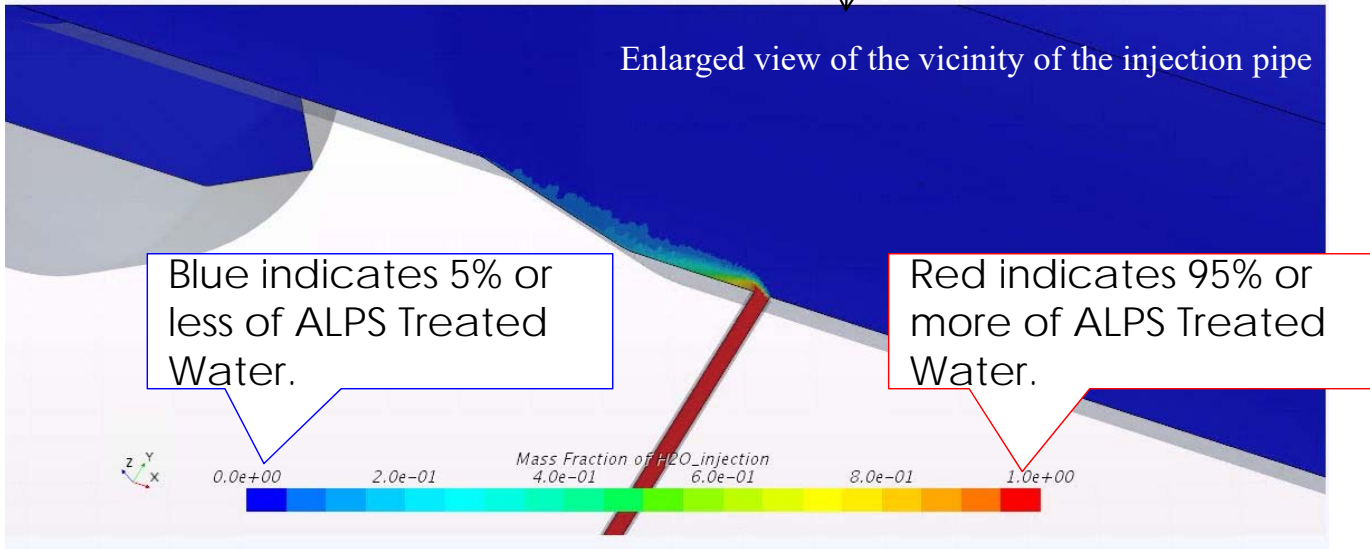
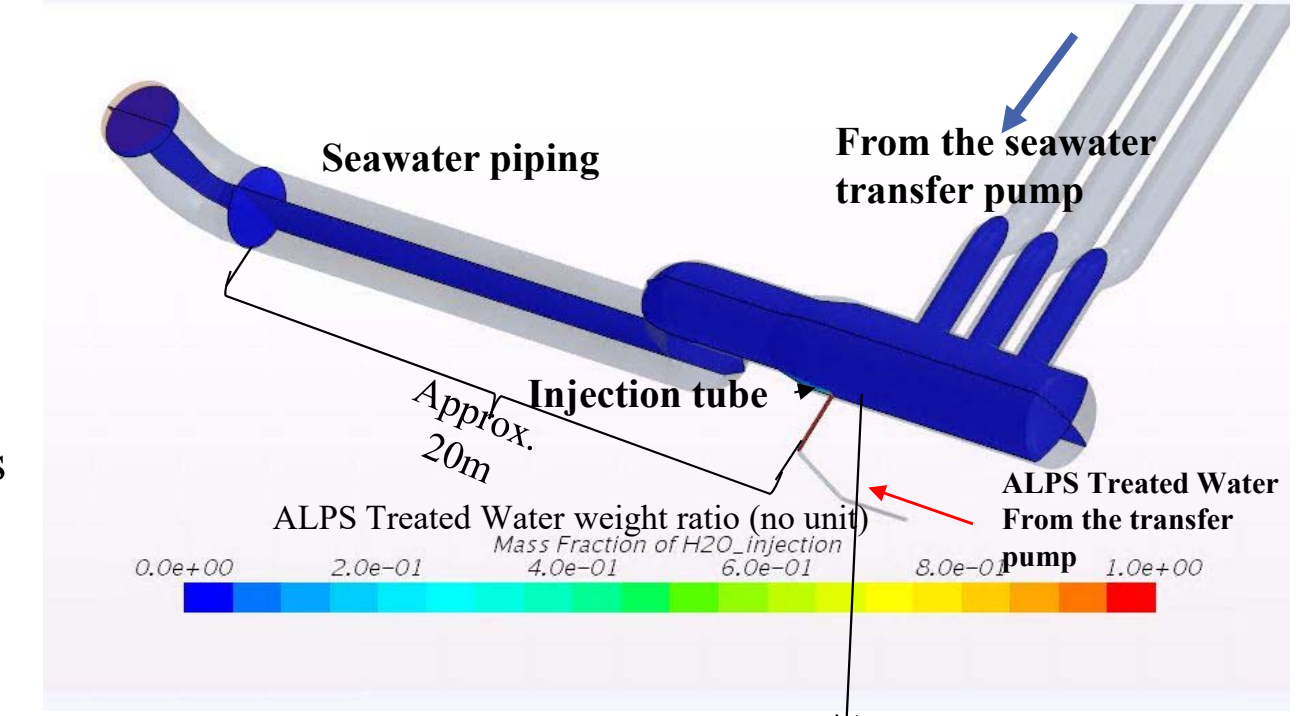



[Supplementary material] Analysis results of diffusion mixing in seawater piping (2/2)

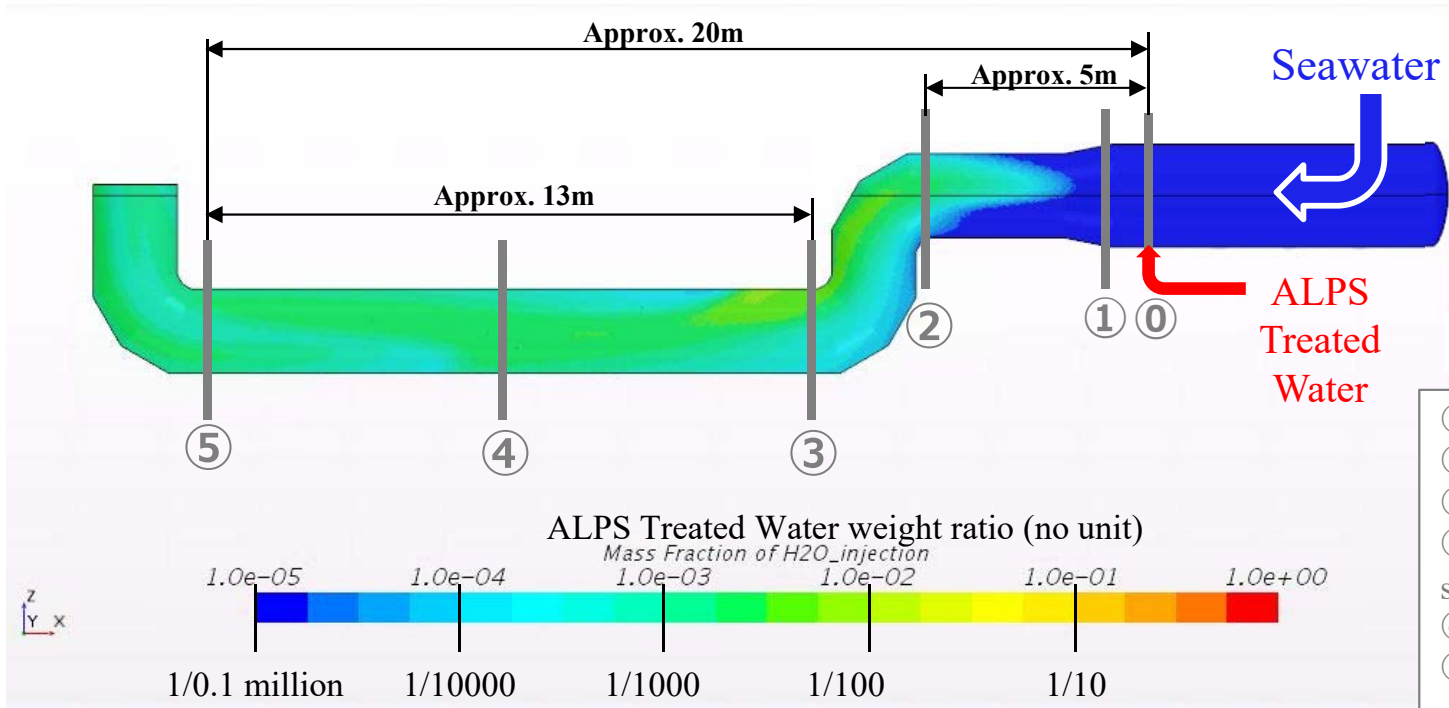

Reference:
Conversion from mass ratio to volume ratio

$$F = \frac{M}{(1 - M) \frac{\rho_i}{\rho_R} + M}$$

F: Volume percentage(-) ρ_i : Density of ALPS treated water(998.3 kg/m³)
M: Mass percentage(-) ρ_R : Density of Seawater(1025 kg/m³)

- ① Water injection position
- ② Mixed header exit
- ③ Front of falling elbow
- ④ Immediately after falling elbow (inlet of straight pipe)
- ⑤ Center of the straight tube
- ⑥ Straight pipe outlet (rising elbow inlet)

ALPS Treated Water is diluted up to 0.23% (about 1/430) and averaged up to 0.14% (about 1/710)
Release of ALPS Treated Water of 150000 becquerels/liter results in a maximum of about 350 becquerels/liter and an average of about 220 becquerels/liter
(Average concentration is equivalent to calculated tritium concentration after seawater dilution)

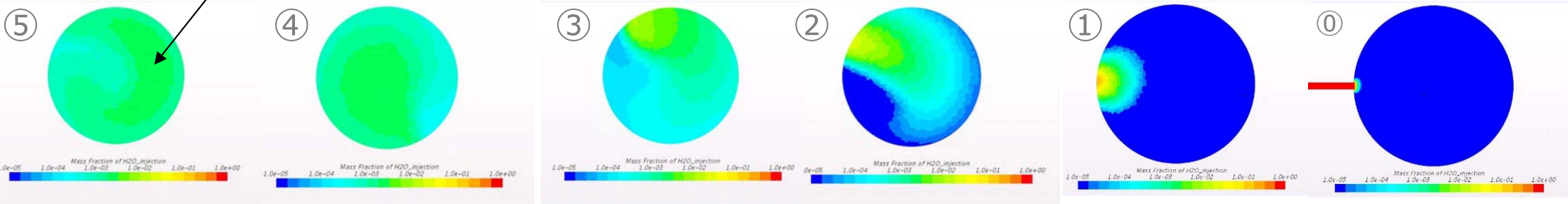

Downstream ←
The Japanese version shall prevail.

→ Upper-stream
48

2.3 ALPS Treated Water Dilution/Discharge Facilities

(2) Confirmation of conformity with matters for which measures should be taken

"15. Other measures to be taken" (emergency isolation valve)

- In addition to the above, take measures when deemed necessary for the prevention of disasters, etc.
- In order to prevent ALPS Treated Water from being released into the ocean in an uncontrolled condition, an emergency isolation valve is installed in the transfer facility and is closed when it is judged that it deviates from the normal operating condition.
 - Interlock

Regarding following condition, the emergency isolation valve is activated to stop the discharge of ALPS Treated Water into the sea.

 - a. The flow rates of the dilution and the transfer volumes are set in the ALPS Treated Water which is discharged. The closing interlock for the emergency isolation valve is installed when flow rate's set point cannot be secured or over the transfer volume.
 - b. The closing interlock for the emergency isolation valve is installed when the abnormal matter is detected from the radiation monitor* installed in the transfer line.

*: Measurement/confirmation equipment confirms that sum of the ratios of legally required concentration of radionuclides (excluding tritium) is less than 1. But just in case, the radiation monitor is also installed in the transfer facilities.

In case an abnormal value is detected from sea monitoring, emergency isolation valve shall be close optional and discharge of ALPS Treated Water into the sea is stopped emergently.

(Implementation plan: II-2-50-Att 2-2)

[Supplementary material] Interlock of emergency isolation valve (1/2)**TEPCO**

- If the dilution rate of ALPS Treated Water is abnormal (stop of the seawater transfer pump, decrease of the seawater flow rate, increase of ALPS Treated Water flow rate, failure of the flow meter) or if the property of ALPS Treated Water is abnormal (radiation monitor operation/failure), close the two emergency isolation valve immediately and stop ALPS Treated Water transfer pump.
- One of the emergency isolation valves shall be installed near the seawater pipe headers in order to minimize the release of ALPS Treated Water in the event of an emergency. The other shall be installed inside the tide dike in preparation for submergence caused by tsunamis.
- Note that, although not an abnormality in the facility, even if an abnormal value is confirmed in the sea area monitoring, the discharge is temporarily stopped

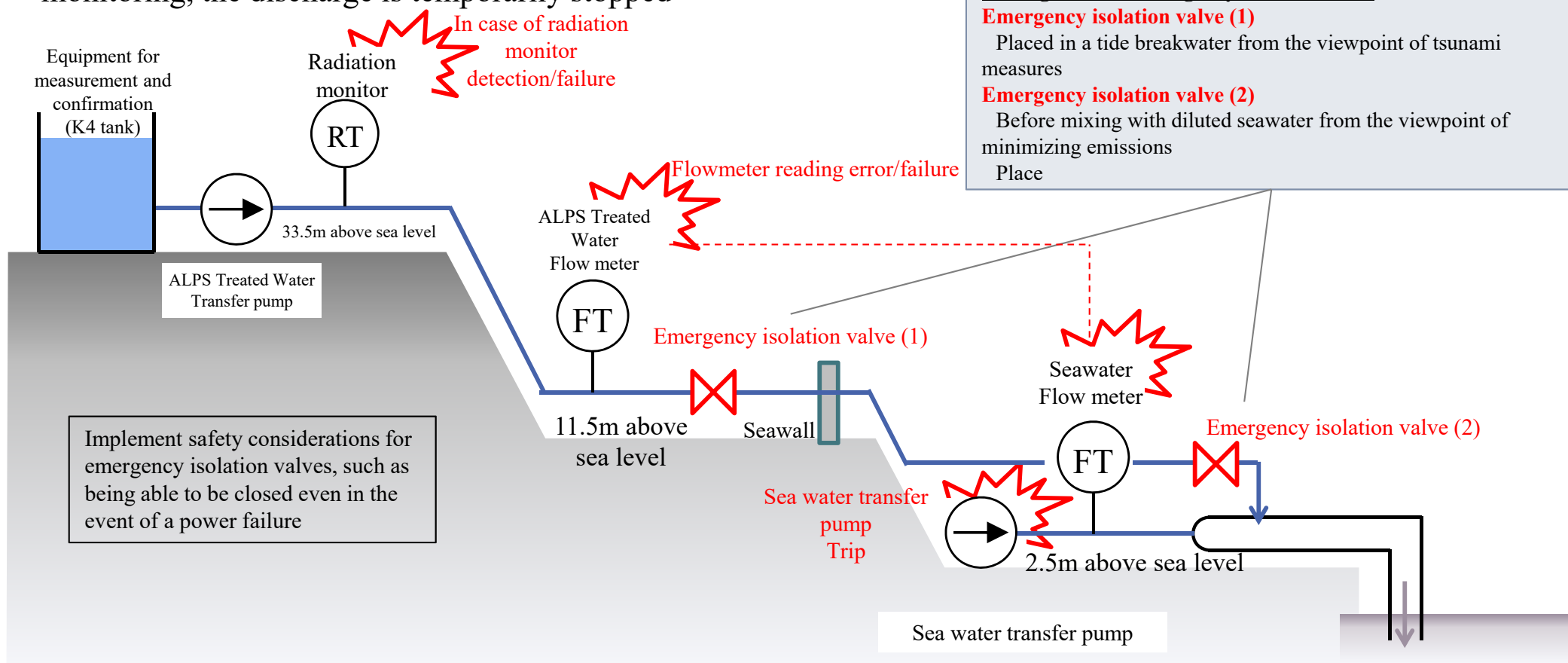

[Supplementary material] Interlock of emergency isolation valve (2/2)



<Detection signal>

**Dilution rate of ALPS Treated Water was abnormal.
Or cannot be confirmed**

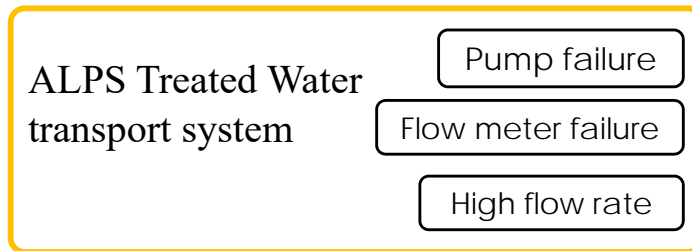
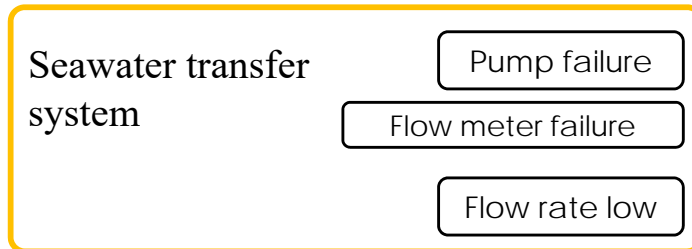

**Radioactivity of ALPS Treated Water was abnormal,
Or cannot be confirmed**



Other equipment malfunctions or any emergency shutdown

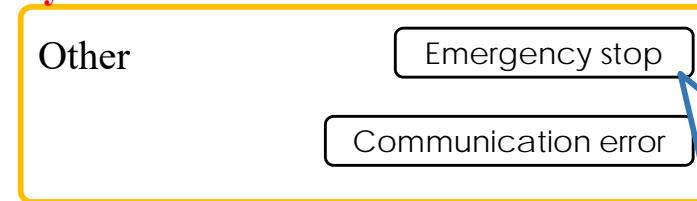

In marine monitoring
Manual stop in case of an error

Emergency Isolation Valve Closure ※1

ALPS treatment water transfer pump-stop ※2

※1: Design-related considerations for stopping the discharge of ALPS Treated Water even in the event of a power failure or other irregularity

※2: Continue operation of seawater transfer pumps with no abnormalities so that ALPS Treated Water can be diluted.

2.4 Water Discharge Facility

(1) Required Function (1/2)

- ① The treated water from ALPS Treated Water Dilution/Discharge Facilities (the water that is diluted with seawater and is water the sum of which ratios to regulatory concentration limit including all nuclides together with tritium is less than 1) can be released at the water outlet in the ocean approximately 1km away from the coast.

(Implementation Plan: II-2-50-7)

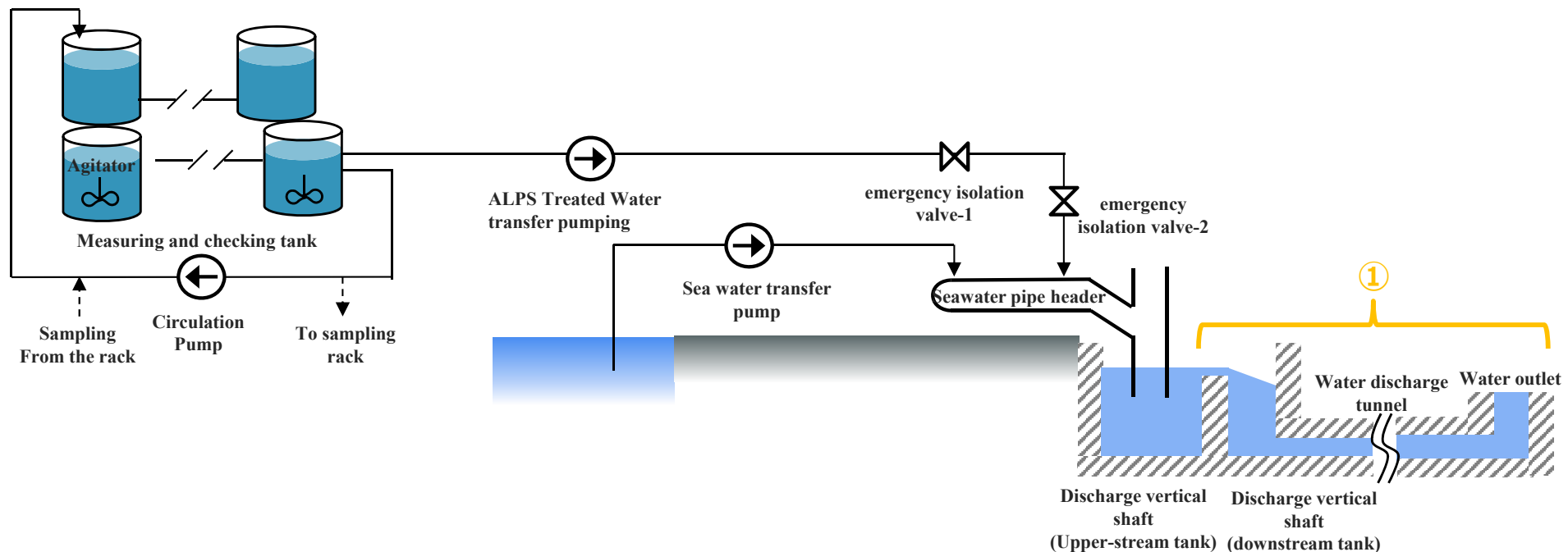

2.4 Water Discharge Facility

(1) Required function (2/2)

■ Concept of Hydraulic Design

- The pressure in the pipe is reduced having atmospheric opening at the discharge vertical shaft.
- The discharge vertical shaft is structured in conjunction with the tide level of the outside ocean through a discharge tunnel and an outlet. Even under the condition of using three seawater transfer pumps to inject seawater ($510,000 \text{ m}^3/\text{day} = 6 \text{ m}^3/\text{s}$), a natural flow is observed through the height difference of the water head between the crest of the discharge vertical shaft (down-stream storage) and the sea-surface (about 1.8m: total loss from the vertical shaft to the outlet).
- Consider rising water level due to surging in case of emergency stop.

List of water levels and altitudes

Vertical shaft Crest	TP+4.50m
Water level Upper-stream of vertical shaft	TP+3.07m
Water level downstream of vertical shaft	TP+2.54m
GL	TP+2.50m
Bulkhead crest	TP+1.50m
HWL	TP+0.76m
Water outlet crest	TP-11.9m
Vertical shaft lower crest	TP-15.1m
Crest of deepest part of tunnel	TP-24.3m

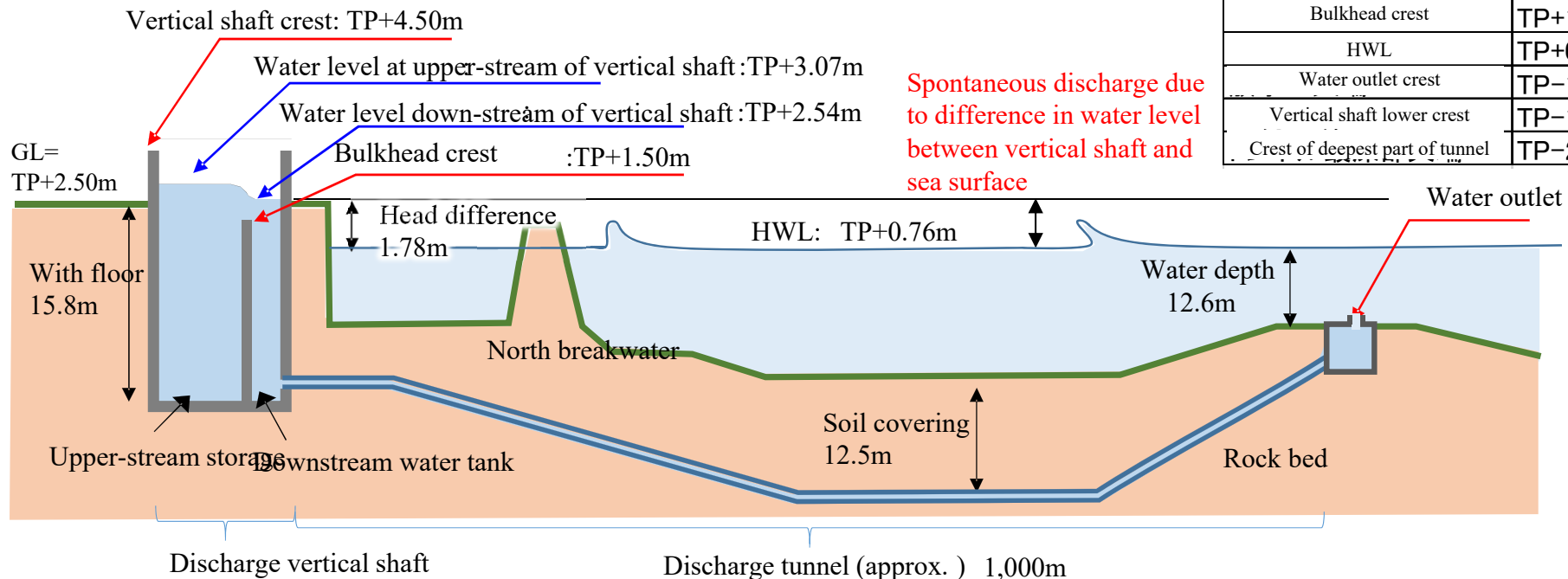

Conceptual Diagram of Water Discharge Facility

2.4 Water Discharge Facility

(2) Confirmation of conformity with matters for which measures should be taken

"14. Design Considerations ① Compliance and Standards"

- Structures, systems and components with safety functions shall conform to standards and standards for design, selection, manufacture and inspection of materials that are deemed appropriate taking into account the importance of the safety functions to be performed by them.
- The design, material selection, and fabrication shall be evaluated in accordance with the following.
 - “Design of Civil Engineering Structure of Thermal and Nuclear Power Plant (enlarged and revised edition)”, (general incorporated association) Electric Power Civil Engineering Association
 - “Standard Specifications of Concrete (design edition)”, (Public Interest Incorporated Association) Japan Society of Civil Engineers,(established in 2017)
 - “Standard Specifications of Tunnels [common edition] / [shield method edition] ”, (Public Interest Incorporated Association) Japan Society of Civil Engineers, (established in 2016)
 - “Standard Specifications for Tunnels, Open-cut Method and Commentary (established in 2016)”
 - “Technical Standards of the Port Facilities”, (Public Interest Incorporated Association) the Ports & Harbors Association of Japan, (2018)
 - “Specifications for Highway Bridges I common edition”, (Public Interest Incorporated Association) Japan Road Association,(2017)
 - “Specifications for Highway Bridges IV substructure edition”, (Public Interest Incorporated Association) Japan Road Association,(2017)
 - “Design Guidance of Utility Tunnel”, Japan Road Association,(1986)

2.4 Water Discharge Facility

(2) Confirmation of conformity with matters for which measures should be taken

"14. Design Considerations ② Design Considerations for Natural Phenomena" (Earthquakes)

- Structures, systems and components having safety functions shall be designed so that they can be classified in terms of seismic design and sufficiently withstand seismic forces for design that are considered appropriate, taking into account the importance of their safety functions and the safety effects in the event of loss of functions due to earthquakes.

- In view of handling the discharge water from ALPS Treated Water Dilution/Discharge Facilities (water, diluted with seawater, and the sum of which ratios to regulatory concentration limit including all nuclides together with tritium is less than 1), the discharge facility is classified as seismic class C according to the degree of radiological impact on the public caused by loss of function of the facility, etc.

(Implementation plan: II-2-50-Att 5-1)

"14. Design Considerations ② Design Considerations for Natural Phenomena" (Natural Phenomena Other than Earthquakes)

- Structures, systems and components with safety functions shall be designed so that the safety of the facilities will not be impaired due to natural phenomena other than earthquakes (tsunamis, heavy rainfall, typhoons, tornadoes, etc.). Structures, systems and components with a particularly high level of importance of safety functions shall be designed in consideration of the conditions that are considered to be the most severe of the expected natural phenomena, or the case where the accident load is appropriately combined with the natural force.
- Tsunami (Implementation Plan: II-2-50-8)
 - Since inundation against tsunami is inevitable, the specifications have wave pressure resistance depending on the restorability.
- Typhoon (storm surge) (Implementation Plan: II-2-50-8)
 - The design should also take into account the impacts of sea level rise due to typhoons (storm surges).

2.4 Water Discharge Facility

(2) Confirmation of conformity with matters for which measures should be taken



"14. Design Considerations ④ Design Considerations for Fires"

- To be designed so that the safety of the facility is not impaired by fire, by appropriately combining measures for fire prevention, fire detection and extinguishment, and mitigation of the impact of fire.
-
- Fire (Implementation Plan: II-2-50-8)
 - To prevent fire, use non-combustible or flame-retardant materials as far as practicable. The risk of fire is very low because seawater is charged inside the facility.

2.4 Water Discharge Facility

(2) Confirmation of conformity with matters for which measures should be taken

"14. Design considerations ⑧ Design considerations for reliability

- SSCs with safety function and monitoring function shall be designed so that their adequately high reliability may be ensured and maintained.
- Structure (Implementation Plan : II-2-50-7)
 - This facility shall have the structure which is less susceptible to earthquake by fixing bottom of this facility to bedrock. And discharge tunnel shall be installed inside bedrock and the shield method shall be adopted to consider the risk during construction of excavation of sea bed and the durability during service period. Then this facility shall have water tightness to place the seal material on covering plate made of reinforced concrete composing the discharge tunnel.
- Soundness Consideration (Implementation Plan : II-2-50-7)
 - The structure is set up to confirm that this facility is within allowance stress level to the normal load, wave load and seismic load. It is also confirmed that no lifting occurs in the structure. And it is confirmed that the durability during service period is ensured to perform irradiation to inspect width of crack and salt damage on the body made of reinforced concrete, and to set appropriate covering depth for reinforcement. Note that maintenance is not required due to design considerations for body made of reinforced concrete during the service period.

2.4 Water Discharge Facility

(2) Confirmation of conformity with matters for which measures should be taken **TEPCO**

"14. Design Considerations ⑧ Design Considerations for Reliability" (continued)

- It has been confirmed that the durability of the water discharge equipment during the service period can be ensured by checking the following table.

Items to be checked for discharge facility

Items to be checked		Discharge vertical shaft (down-stream storage)	Discharge Tunnel	Outlet	Content of check
At all times	Structure	○	○		※1 Within allowance stress level *1
	Structure (Waves)			○	※1 Within allowance stress level *1
	Crack	○	○	○	※2 The crack width shall not exceed the allowance crack width. *2
	Salt damage	○	○	○	*2 The chloride ion concentration at the steel position does not reach the generation limit of steel corrosion. *2
	Floating	○		○	No floating shall occur.
During an earthquake		○	○	○	※3 Should be within allowance stress level from earthquake *3

※1 Safety: The stress of the material caused by the action of the load shall be within the allowable stress.

※2 Durability: During the design service life, the performance of the structure shall not be degraded due to steel corrosion associated with cracking or chloride ion ingress.

※3 Seismic resistance: Seismic Class C shall be used, and checks shall be conducted using the design horizontal seismic intensity $kh=0.2$.

2.4 Water Discharge Facility

(2) Confirmation of conformity with matters for which measures should be taken

"14. Design Considerations ⑨ Design Considerations for Inspectability"

- Structures, systems and components having safety functions shall be designed so that their functions can be inspected in an appropriate manner in order to confirm their soundness and capability.
- In the installation of the equipment, it is designed considering future maintenance.
- With regard to the management of facility maintenance, a long-term inspection plan shall be prepared and inspections shall be carried out based on the inspection plan.
- Consideration for the inspection of the water discharge equipment to be installed this time is as follows according to the targets for inspection before use.
 - In the service period, the Discharge vertical shaft (downstream tank), discharge tunnel, and outlet are filled with seawater as an integral structure, and a structure interlocked with the tide level of the open sea is adopted. Considering the design of the reinforced concrete framework, maintenance is not required during the service period. However, the design allows inspection of the interior from the Discharge vertical shaft (downstream tank) or outlet.

"III. Items concerning Measures Taken for Security of the Specified Nuclear Facility"

- By taking appropriate measures such as operation management, maintenance management, radiation control, radioactive waste management, emergency measure and on-site and off-site environmental radiation monitoring, etc., “II. Items concerning Measures to be taken for Design and Facilities” shall be ensured to be appropriately and reliably implemented, and workers’ and on-site and off-site safety shall be ensured.
-
- Management of Radioactive Liquid Waste, etc. (Implementation Plan: III-3-2-1-2)
 - Overview
 - The treated water that satisfies the value less than 1 of the sum of ratios to regulatory concentration limits other than tritium (hereinafter referred to as “ALPS Treated Water”) shall be diluted with seawater and then discharged into the sea.
 - Radioactive Liquid Waste to be Managed and Management Methods
 - ALPS Treated Water shall be analyzed for its radionuclides other than H-3 and H-3 in the measurement/confirmation facilities prior to discharge, and Tepco confirms that radionuclides other than H-3 satisfy the criteria. The treated water shall be discharged after diluting with seawater in dilution facility in order to reduce H-3 concentration.
 - For ALPS Treated Water, it shall be confirmed that the sum of ratios to regulatory concentration limit other than H-3 is less than 1 by measuring, etc. In addition, the discharge flow rate and diluted seawater flow rate are set so that the H-3 concentration in the discharge vertical shaft (Upper-stream tank) is less than 1, 500Bq/L and more than 100 times diluted with seawater. The amount of discharge H-3 shall be within the range of 22 trillion Bq/year.
 - The radionuclides to be measured other than H-3 and concentration confirmation methods shall be stipulated in the in-house manual.

- Comments from NRA at the “Meeting for the consideration of selecting the nuclides to be measured of ALPS Treated Water ” hold on Oct. 18th, 2021 are shown below.
 - When considering the selection of the nuclides to be measured of ALPS Treated Water, after confirmed the existence of nuclides that cannot be verified to be not contained in ALPS-treated water, it shall be considered including the handling of quality management for selection process, for the nuclides that it is difficult to measure and need to be judge the activity concentration by assessment.
 - As for other nuclides, provide details of the considerations when selecting of Fe-55, Ni-59, Mo-93, Sn-121m based on the results of decommissioning and investigation of buried facilities.
 - It shall be clarified the criteria and grounds for being considering excluding the measurement of nuclides whose ratios regulatory concentration limits are 1/100 or less due to attenuation by the elapsed time immediately after the earthquake.



We will continue to consider and will inform as soon as details finalized.

"III. Items concerning Measures Taken for Security of the Specified Nuclear Facility" (continued)

- Action in response to the "Basic Policy on handling of the ALPS Treated Water" (Implementation Plan: III-3-2-2-6)

At the 5th Inter-Ministerial Council for Contaminated Water, Treated Water and Decommissioning (held on 13th April, 2021), the "Basic Policy on handling of the ALPS Treated Water" (hereinafter referred to as the "Government Policy") was issued.

Tepco issued "TEPCO Holdings' Action in Response to Government's Policy on the Handling of the ALPS Treated Water from the Fukushima Daiichi Nuclear Power Station", on April 16th in same year and will take measure in accordance with Government Policy.

- ① The tritium concentration of discharged water diluted with seawater is less than 1,500Bq/L (refer to pp.62)
- ② The amount of discharged tritium is within the range of 22 trillion Bq per year (refer to pp.62)
- ③ Emergency isolation valves are installed to stop the transfer of ALPS Treated Water when abnormal event happens (refer to pp.50).
- ④ The safety for radiation impact on humans and the environment in case of discharge into the sea of ALPS Treated Water shall be assessed.

For the radiation impact on humans and the environment described in ④ above, the evaluation results at the design stage as of November 2021 are attached as a reference.

Reference-1 Radiation Impact Assessment Report regarding the discharge into the sea of ALPS Treated Water (Design Stage)

Reference materials

[Reference] Basis for Calculation of Exposure Evaluation on Radioactive Substances Transition to the Air

■ Set value of the exposure assessment

No.	Item	Numerical value	Unit	Basis for calculation
①	Estimated leakage water storage area at the time of loss of function	2201	m ²	Estimated leakage water storage area at the time of loss of function
②	Radioactivity concentrationEvaluation	1.1E+06	Bq/L	Referred to the concentration of H-3 used in the site boundary dose evaluation
③	Typical wind speed	3.1	m/s	Typical wind speed at 1F described in Permission for Installation
④	Evaporation coefficient	0.403	Mm/day/mb	0.13 × Typical wind speed (from Research Report 376008, equation for Lake Hefner (1954), Central Research Institute of Electric Power Industry report)
⑤	Saturated vapor pressure difference between the water surface and 2m directly above the water surface	23.366	Mb	Saturated vapor pressure assuming a water surface of 20°C (assuming tritium pressure in vapor is 0) (from the steam table of the Japan Society of Mechanical Engineers)
⑥	Water surface evaporation	9.42	Mm/day	Evaporation coefficient × saturated vapor pressure difference between the water surface and 2m directly above the water surface
⑦	Evaporation amount	2.40E-4	m ³ /s	Water surface evaporation × estimated leakage water storage area at the time of loss of function/1000 (mm/m)/24/3600 (s/day)
⑧	Relative concentration based on X/Q (Meteorological Guidelines)	1.9E-04	s/m ³	Referred to "Meteorological Guidelines for Safety Analysis of Nuclear Power Reactor Facilities" (NSC) (Implementation Plan III, Part 3, 2.2 Dose Assessment (Equation 2-2-1)) (calculated with an discharge height of 0m, atmospheric stability of D, wind speed of 3.1m, and a distance of 442m to the nearest evaluation point No. 70)
⑨	Inhalation rate	1.2	m ³ /h	Review Guidelines for Safety Assessment of Light Water Reactor Facilities for Power Generation (NSC) for adult inhalation rate during activity
⑩	Duration of Inhalation	336	H	Assumed recovery time at loss of function (assuming 24-hour breathing duration)
⑪	Effective dose coefficient of inhalation intake	1.8E-08	mSv/Bq	Announcement Stipulating the Dose Limit Based on Regulations Regarding the Refining Business of Nuclear Raw Material and Nuclear Fuel Material," (Appended Table 1)

■ Calculation of Exposure Evaluation(rounded figures correspond to the numbers on the previous page.)

➤ Discharge rate

$$\text{Activity concentration (②)} \times \text{Evaporation amount (⑦)} \times 1000 \text{ (L/m}^3\text{)} = 2.64\text{E}+5 \text{ Bq/m}^3$$

➤ Site boundary concentration

$$\text{Discharge rate} \times \text{Relative concentration based on X/Q (Meteorological Guidelines) (⑧)} = 5.01\text{E}+1 \text{ Bq/m}^3$$

➤ Exposure dose

$$\text{Site boundary concentration} \times \text{Inhalation rate (⑨)} \times \text{Duration of inhalation (⑩)} \times \text{Effective dose coefficient of inhalation intake (⑪)} \times 1000 \text{ (}\mu\text{ Sv/mSv)} = \mathbf{0.36 \mu\text{ Sv/incident}}$$

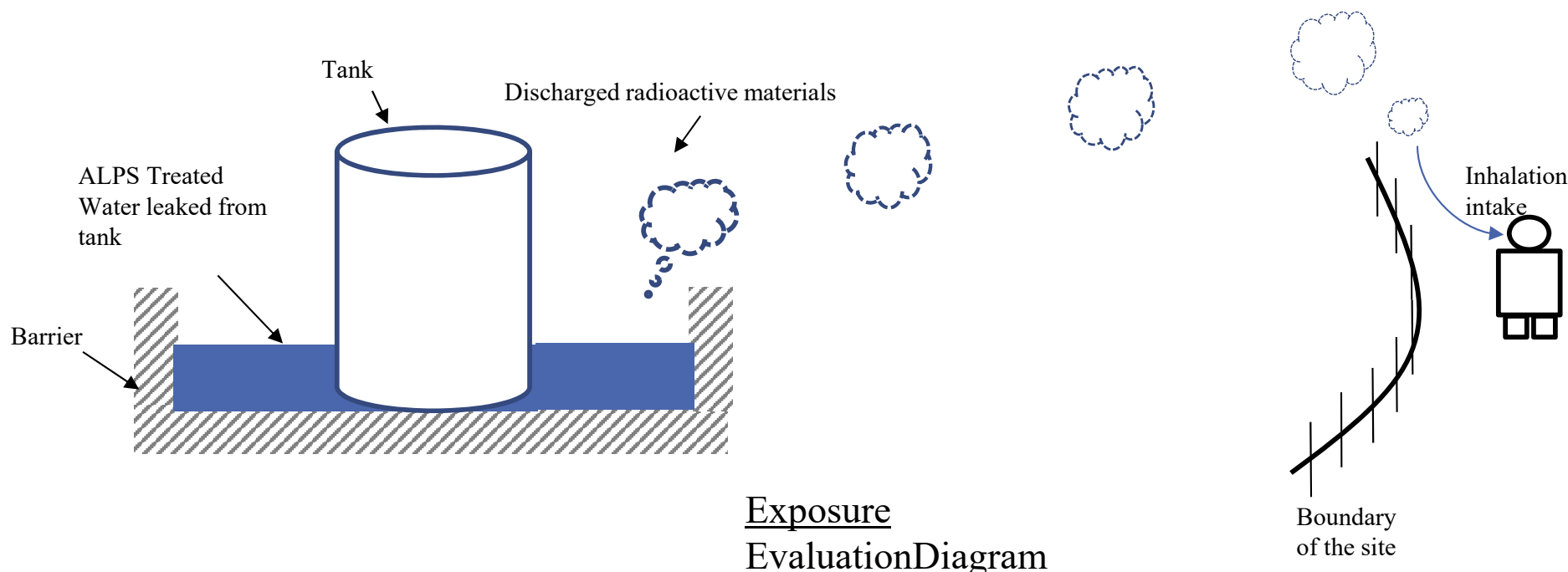

[Reference] Exposure Evaluation at the time of Liquid Leakage

- Assumption of “loss of function of facilities, etc.” of ALPS Treated Water Dilution/Discharge Facilities
 - It is assumed that ALPS Treated Water Dilution/Discharge Facilities get damage due to earthquake and the leakage of storage water occurs.
 - Leaked water flows out of the site through drainage channels, etc. However, it is assumed that there is no dilution midway as a conservative evaluation.
 - It is assumed that adults intake 2 liters of leaked water once.

- Exposure Dose Evaluation: 32 μSv for a single event

Item		Unit	Nuclides other than tritium	H-3	
Legally required concentration		Bq/L	Even when as a conservative considering “sum of ratios to regulatory concentration limit” of the 7 major nuclides is set to 1, while the same criteria of the 7 major nuclides is less than 1 based on the latest effort of the ALPS, it shall be 1 mSv/year/365 days \div 3 μSv , based on the concept \times 1 of regulatory concentration limit in water. Therefore, impact of nuclides other than tritium is considered about 10 μSv , even conservative view.	60,000	Total
Tank concentration for assessment				620,000 \times 2	
[Reference]	K4 area A1 tank (middle row)			154,000	
	G1 area B1 tank			498,000	
Effective dose coefficient				$\mu\text{Sv/Bq}$	
Intake amount		L/Event 1	2		
Exposure Dose Evaluation Value		μSv	10	22	32

\times 1: Concentration at which the average dose rate reaches 1mSv per year if 2L of drinking is continued daily until the age of 70 years after birth.

\times 2: Average concentration in all existing tanks

[Reference] Basic Specifications for Equipment and Facilities (ALPS Treated Water Dilution/Discharge Facilities)

■ Circulation pump

Number of units	2
Capacity	160m ³ /h (per unit)

■ ALPS Treated Water transfer pump

Number of units	2
Capacity	30m ³ /h (per unit)

■ Sea water transfer pump

Number of units	3
Capacity	7, 086m ³ /h (per unit)

■ Discharge guide

Number of units	1
Main dimensions	2,100 mm × 2,100 mm × 7,096 mm (Upper-stream side) 2,140 mm × 2,140 mm × 11,144mm (downstream side)
Material	SUS316L

■ Discharge vertical shaft (upper-stream storage)

Number of units	1
Structure	Reinforced concrete construction

[Reference] Basic Specifications for Pipe (ALPS Treated Water Dilution/Discharge Facilities)

Name	Specification	
From the measurement /confirmation tank outlet to the circulation pump inlet (Steel pipe)	Nominal diameter /thickness Material Max. operating pressure Max. operating temperature	200A/Sch.20S SUS316LTP 0.49MPa 40°C
(Polyethylene pipe)	Nominal diameter Material Max. operating pressure Max. operating temperature	Equivalent to 200A Polyethylene 0.49MPa 40°C
(Pressure resistant hose)	Nominal diameter Material Max. operating pressure Max. operating temperature	Equivalent to 200A Synthetic rubber 0.49MPa 40°C
(Expansion joint)	Nominal diameter Material Max. operating pressure Max. operating temperature	Equivalent to 200A Synthetic rubber 0.49MPa 40°C
From the circulation pump outlet to the measurement /confirmation tank inlet (steel pipe)	Nominal diameter /thickness Material Max. operating pressure Max. operating temperature	125A/Sch.20S 150A/Sch.20S 200A/Sch.20S SUS316LTP 0.98MPa 40°C
(Polyethylene pipe)	Nominal diameter Material Max. operating pressure Max. operating temperature	Equivalent to 150A Polyethylene 0.98MPa 40°C
(Expansion joint)	Nominal diameter Material Max. operating pressure Max. operating temperature	Equivalent to 125A Synthetic rubber 0.98MPa 40°C

Name	Specification	
Between measurement /confirmation tank (Steel pipe)	Nominal diameter/thickness Material Max. operating pressure Max. operating temperature	200A/Sch.20S SUS316LTP 0.49MPa 40°C
(Polyethylene pipe)	Nominal diameter Material Max. operating pressure Max. operating temperature	Equivalent to 200A Polyethylene 0.49MPa 40°C
(Pressure resistant hose)	Nominal diameter Material Max. operating pressure Max. operating temperature	Equivalent to 200A Synthetic rubber 0.49MPa 40°C
From the measurement /confirmation tank outlet to the ALPS Treated Water transfer pump inlet (Steel pipe)	Nominal diameter/thickness Material Max. operating pressure Max. operating temperature	100A/Sch.20S 150A/Sch.20S SUS316LTP 0.49MPa 40°C
(Polyethylene pipe)	Nominal diameter Material Max. operating pressure Max. operating temperature	Equivalent to 100A Equivalent to 150A Polyethylene 0.49MPa 40°C
(Expansion joint)	Nominal diameter Material Max. operating pressure Max. operating temperature	Equivalent to 100A Synthetic rubber 0.49MPa 40°C

[Reference] Basic Specifications for Pipe (ALPS Treated Water Dilution/Discharge Facilities) 

Name	Specification	
From the ALPS Treated Water transfer pump outlet to seawater pipe header inlet (Steel pipe)	Nominal diameter /thickness Material Max. operating pressure Max. operating temperature	100A/Sch.40 STPG370 0.98MPa 40°C
(Steel pipe)	Nominal diameter /thickness Material Max. operating pressure Max. operating temperature	65A/Sch.20S 100A/Sch.20S 150A/Sch.20S SUS316LTP 0.98MPa 40°C
(Polyethylene pipe)	Nominal diameter Material Max. operating pressure Max. operating temperature	Equivalent to 100A Polyethylene 0.98MPa 40°C
(Expansion joint)	Nominal diameter Material Max. operating pressure Max. operating temperature	Equivalent to 65A Equivalent to 100A Synthetic rubber 0.98MPa 40°C

Name	Specification	
From the seawater transfer pump outlet to the seawater pipe header inlet connection (Steel pipe)	Nominal diameter /thickness Material Max. operating pressure Max. operating temperature	800A/12.7mm 900A/12.7mm STPY400 0.60MPa 40°C
(Steel pipe)	Nominal diameter/thickness Material Max. operating pressure Max. operating temperature	900A/Sch.20S SUS329J4LTP 0.60MPa 40°C
(Expansion joint)	Nominal diameter Material Max. operating pressure Max. operating temperature	Equivalent to 800A Equivalent to 900A Synthetic rubber 0.60MPa 40°C
Seawater pipe header (Steel pipe)	Nominal diameter/thickness Material Max. operating pressure Max. operating temperature	1800A/13mm 2200A/16mm SM400B 0.60MPa 40°C
From the seawater pipe header outlet to the discharge guide (Steel pipe)	Nominal diameter/thickness Material Max. operating pressure Max. operating temperature	1800A/13mm SM400B 0.60MPa 40°C
(Expansion joint)	Nominal diameter Material Max. operating pressure Max. operating temperature	Equivalent to 1800A Synthetic rubber 0.60MPa 40°C

- Measurement /confirmation tank (K4 tank is used)

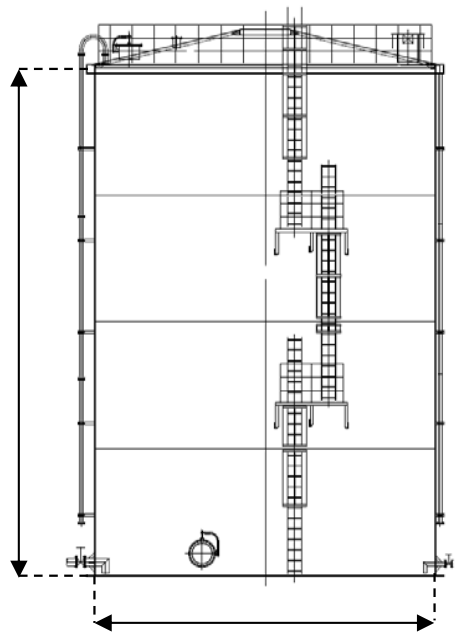
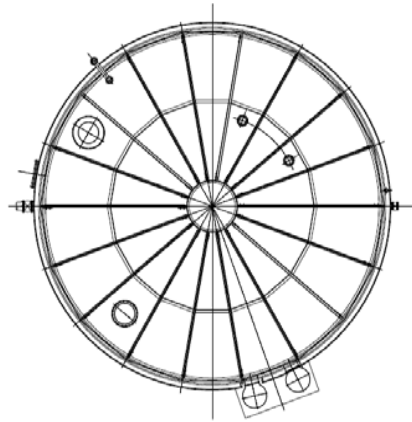

Height: 14,565mm

Inner diameter: 10,000mm

Tank capacity		m ³	1,000
Main dimensions	Inner diameter	mm	10,000
	Shell plate thickness	mm	15
	Bottom plate thickness	mm	25
	Height	mm	14,565
Nozzle stub thickness	100A	mm	8.6
	200A	mm	12.7
	600A	mm	16.0
Material	Shell plate and bottom plate	-	SS400
	Tube stand	-	STPT410,SS400

➤ Design temperature 50°C

[Reference] Specifications of Related Facility for the Measurement /Confirmation Tank



- Tank barrier * (Install the barrier around the foundation to prevent leakage expansion) (Implementation plan: II-2-5-Att 12-25)

The inner capacity of the barrier around the foundation, it shall be the total capacity of: storage capacity which can be secure 1 unit per 20 units of tank (1 unit per 20 units in the case of 20 or more, or 1 unit even if less than 20 units), and which has the margin height (about 20cm in height) considering the work in the case of heavy rain.

※For tank barriers, those in the K4 area shall be used together.

Installation location	Number of installed tanks	Assumed leakage		Inner capacity of the barrier around the foundation (m ³)	(planned value)			
		Number of units	Capacity(m ³)		Area inside barrier around the foundation (m ²)	Tank-occupied area (m ²)	Capable storage area (m ²)	Height of the barrier around the foundation (m)
K4	35	1.75	1,750	2190 or more	5,145	2,944	2,201	0.995 or more

- Supplied pipe for measurement/confirmation tank

	Nominal diameter	Material	Max. operating pressure	Max. operating temperature
Connecting tube (pressure-resistant hose)	Equivalent to 200A	EPDM synthetic rubber	1.0MPa	50°C
Inlet piping (steel pipe)	100A	STPT410	1.0MPa	50°C

- Water level gauge for measurement/confirmation tank

Detection method	TEPCO control accuracy
Microwave type	±1%

- Supplied valves for measurement/confirmation tank

	Nominal diameter	Material	Max. operating pressure	Max. operating temperature
Coupling valve	Equivalent to 200A	FCD450-10	1.0MPa	50°C

- Agitation equipment

Number of units
30

■ Discharge vertical shaft (down-stream storage)

Number of units	1
Structure	Reinforced concrete construction

■ Discharge tunnel

Number of units	1
Structure	Reinforced concrete construction

■ Outlet

Number of units	1
Structure	Reinforced concrete construction

[Reference] Items to be Checked on Inspection

- It shall be conducted based on II-2-50- Att 4-1 Table-1 Check items (circulation pumps, ALPS Treated Water transfer pumps, agitation equipment, seawater transfer pumps).

Matters to be Confirmed	Check items	Details	Acceptance Criteria
Structural strength • Seismic resistance	Visual check	Confirm the visual of each part.	No significant defect.
	Installation check	Confirm the installation conditions of the equipment.	Carrying out construction and installation based on the Implementation plan.
	Leak check ※1	Confirm no leakage from the pressure resistant parts under the operating pressure.	No significant leakage from the pressure resistant parts.
Performance	Operation performance check ※1	Confirm the pump operation.	Satisfying the criteria described in the Implementation Plan. In addition, No abnormal noise, smoke, vibration, etc.

※1: Not applicable to the Agitation equipment because it is the rotation machinery with propeller wings installed in the water of the measurement/confirmation tanks and there is no leakage point to be confirmed. In addition, it is difficult to confirm abnormal noise, smoke, vibration, etc. during the operation performance check. Therefore, it shall be confirmed whether it is activated or not by electric current measurement, etc.

[Reference] Items to be Checked on Inspection

- It shall be conducted based on II-2-50- Att 4-2 Table 2-1 Check items (main pipe (steel pipes)).

Matters to be Confirmed	Check items	Details	Acceptance Criteria
Structural strength • Seismic resistance	Material check	Confirm the main materials described in the Implementation Plan with the records.	Following the Implementation Plan.
	Dimension check	Confirm the outer diameter and thickness described in the Implementation Plan with the records.	Following the Implementation Plan.
	Visual check ※1	Confirm the visual of each part.	No significant defects.
	Installation check ※1	Confirm the installation conditions of the pipes.	Carrying out construction and installation based on the Implementation plan.
	Pressure resistance/ Leakage check ※1	Holding a fixed time at 1.25 times the maximum working pressure, confirm that the product withstands the pressure and that there is no leakage from the pressure resistant parts.	Withstanding 1.25 times the maximum allowable working pressure with no abnormalities. In addition, there no leakage from the pressure resistant parts.
Functions and performance	Water flow check	Confirm water flow.	Possible to flow water.

※1: On site, it shall be within the scope that can be implemented, and the quality records shall be confirmed as necessary.

[Reference] Items to be Checked on Inspection

- It shall be conducted based on II-2-50- Att 4-3 Table 2-2 Check items (main pipes (polyethylene pipes)).

Matters to be Confirmed	Check items	Details	Acceptance Criteria
Structural strength • Seismic resistance	Material check	Confirm the main materials described in the Implementation Plan with the records.	Following the Implementation Plan.
	Dimension check	Confirm the outer diameter and thickness described in the Implementation Plan with the records.	Following the Implementation Plan.
	Visual check ※1	Confirm the visual of each part.	No significant defects.
	Installation Check ※1	Confirm the installation conditions of the pipes.	Carrying out construction and installation based on the Implementation plan.
	Pressure resistance/ Leakage check ※1	Holding a fixed time at the maximum working pressure or higher, confirm that the product withstands the pressure and that there is no leakage from the pressure resistant parts.	Withstanding the maximum allowable working pressure and no abnormalities. In addition, no leakage from the pressure resistant parts.
Functions and performance	Water flow check	Confirm water flow.	Possible to flow water.

※1: On site, it shall be within the scope that can be implemented, and the quality records shall be confirmed as necessary.

[Reference] Items to be Checked on Inspection

- It shall be conducted based on II-2-50- Att 4-4 Table 2-3 Check items (main pipes (pressure-resistant hoses))

Matters to be Confirmed	Check items	Details	Acceptance Criteria
Structural strength • Seismic resistance	Material check	Confirm the main materials described in the Implementation Plan with the records.	Following the Implementation Plan.
	Dimension check	Confirm the outer diameter and thickness described in the Implementation Plan with the records.	Following the Implementation Plan.
	Visual check ※1	Confirm the appearance of each part.	No significant defects.
	Installation check ※1	Confirm the installation condition of the pipes.	Carrying out construction and installation based on the Implementation plan.
	Pressure resistance/ Leakage check ※1	Holding a fixed time at 1.25 times the maximum working pressure or higher, confirm that the product withstands the pressure and that there is no leakage from the pressure resistant parts.	Withstanding 1.25 times the maximum allowable working pressure with no abnormalities. In addition, there no leakage from the pressure resistant parts.
Functions and performance	Water flow check	Confirm water flow.	Possible to flow water.

※1: On site, it shall be within the scope that can be implemented, and the quality records shall be confirmed as necessary.

[Reference] Items to be Checked on Inspection

- It shall be conducted based on II-2-50- Att 4-5 Table 2-4 Check items (main pipes (expansion joint))

Matters to be Confirmed	Check items	Details	Acceptance Criteria
Structural strength • Seismic resistance	Material check	Confirm the main materials described in the Implementation Plan with the records.	Following the Implementation Plan.
	Dimension check	Confirm the outer diameter and thickness described in the Implementation Plan with the records.	Following the Implementation Plan.
	Visual check ※1	Confirm the visual of each part.	No significant defects.
	Installation check ※1	Confirm the installation condition of the pipes.	Carrying out construction and installation based on the Implementation plan.
	Pressure resistance/ Leakage check ※1	Holding a fixed time at 1.25 times the maximum working pressure, confirm that the product withstands the pressure and that there is no leakage from the pressure resistant parts.	Withstanding 1.25 times the maximum allowable working pressure with no abnormalities. In addition, there no leakage from the pressure resistant parts.
Functions and performance	Water flow check	Confirm water flow.	Possible to flow water.

※1: On site, it shall be within the scope that can be implemented, and the quality records shall be confirmed as necessary.
The Japanese version shall prevail.

[Reference] Items to be Checked on Inspection

- It shall be conducted based on II-2-50- Att 4-5 Table-3 Check items (Leakage Detectors and Alarms).

Matters to be Confirmed	Check items	Details	Acceptance Criteria
Structural strength	Visual check	Confirm the visual of each part.	No significant defects.
	Installation check	Confirm the installation positions and conditions of the equipment.	Carrying out construction and installation based on the Implementation plan.
Function	Leakage alarm check	Confirm that the alarm activates as set.	Alarm activation within the allowable range.

[Reference] Items to be Checked on Inspection

- It shall be conducted based on II-2-50- Att 4-6 Table-4-1 Check items (measurement /confirmation tanks) ※1.

Matters to be Confirmed	Check items	Details	Acceptance Criteria
Structural strength • Seismic resistance	Material check	Confirm the material to be used with a certificate of material. Confirm the delivery record and product specifications for the connecting pipe and connecting valve.	Using the materials described in the Implementation Plan. The product specifications (maximum working pressure) of the connecting pipes and connecting valves shall be equal to or higher than the water head pressure of the tanks.
	Dimension check	Confirm the main dimensions (plate thickness, inner diameter, and height).	Following the Implementation Plan.
	Visual check	Confirm the visual of the tank body (including paint condition), connecting pipes and connecting valves.	No significant defects..
	Installation check	Confirm the conditions of the assembly and installation.	No abnormality in the assembly condition and installation condition.
		Confirm the unevenness of the tank foundation.	No abnormal unevenness.
	Pressure resistance/leakage check	Perform pressure resistance and leakage tests based on design and construction standards.	No significant leakage from any part and no drop in water level.
	Ground bearing capacity check	Confirm the bearing capacity of the foundation of the tanks in the bearing capacity tests.	Satisfying the necessary bearing capacity.

※1: Since it is a use change from "II 2 5 Contaminated Water Treatment Facility, etc." (completion of pre-use inspection), these items are basically confirmed with the pre-service inspection records, but witness or quality records confirmation is conducted as necessary.

[Reference] Items to be Checked on Inspection

- It shall be conducted based on II-2-50- Att 4-6 Table-4-1 Check items (measurement /confirmation tanks) ※1.

Matters to be Confirmed	Check items	Details	Acceptance Criteria
Functions and performance	Alarm check	Confirm that alarm is activated by a signal associated with tanks' water level "high-high".*2	Activating alarm by a signal associated with tanks' water level "high-high" ※2
	Dimension check ※3	Confirm the inner capacity of the barrier around the foundation.	Satisfying the capacity inside barrier equivalent to the required capacity.
	Visual check	Confirm the visual of the barrier around the foundation.	No significant defect.
	Storage function	Confirm that tanks can store without leakage.	No leakage from the tanks and attached facilities (connecting pipes, connecting valves, manholes, drain valves).

※1: Since it is a use change from "II 2 5 Contaminated Water Treatment Facility, etc." (completion of pre-use inspection), these items are basically confirmed with the pre-service inspection records, but witness or quality records confirmation is conducted as necessary.

※2: Signal name varies depending on the tank.

※3: Confirm the capacity of the barrier described in K4 for the location of "II. 2 5 Attachment-12 Appendix-6 Table 2".

[Reference] Items to be Checked on Inspection

- It shall be conducted based on II-2-50- Att 4-7 Table-4-2 Check items (measurement/confirmation tank inlet pipe (steel pipes)) ※1.

Matters to be Confirmed	Check items	Details	Acceptance Criteria
Structural strength • Seismic resistance	Material check	Confirm the main materials described in the Implementation Plan with a certificate of material or delivery note.	Following the Implementation Plan.
	Dimension check	Confirm the main dimensions described in the implementation plan with a certificate of material or delivery note.	Following the Implementation Plan.
	Visual check	Confirm the visual of each part by witness or with records.	No significant defects..
	Installation check	Confirm by witness or with records that the equipment is installed as shown in the drawing.	Carrying out construction and installation based on the drawing.
	Pressure resistance/ Leakage check (Note 1)		①Holding a fixed time at 1.5 times the maximum working pressure, confirm that the product withstands the pressure and that there is no leakage from the pressure resistant parts, by witness or with records.
②Confirm no leakage from the pressure resistant parts at the operating pressure under operational pressure by witness or with records.. ※2			No leakage from the pressure resistant parts.
Functions and performance	Water flow check	Confirm water flow.	Possible to flow water.

※1: Since it is a use change from "II 2 5 Contaminated Water Treatment Facility, etc." (completion of pre-use inspection), these items are basically confirmed with the pre-service inspection records, but witness or quality records confirmation is conducted as necessary.

※2: Alternative inspection such as torque check is carried out for flange part of pipes where leakage inspection at pressure resistant parts cannot be conducted under the operational pressure.

Note 1 : Pressure resistance/Leakage check shall be confirmed by either ① or ②.

The Japanese version shall prevail.

[Reference] Items to be Checked on Inspection

- It shall be conducted based on II-2-50-Att 4-8 Table-5 Check items (discharge guides).

Matters to be Confirmed	Check items	Details	Acceptance Criteria
Structural strength • Seismic resistance	Material check	Confirm the main materials described in the Implementation Plan.	Following the Implementation Plan.
	Dimension check	Confirm the main dimensions described in the Implementation Plan.	Following the Implementation Plan.
	Visual check ※1	Confirm the visual of each part.	No significant defect.
	Installation check ※1	Confirm the installation conditions of the equipment.	Carrying out construction and installation based on the Implementation Plan.
Functions and performance	Water flow check	Confirm water flow.	Possible to flow water.

※1: On site, it shall be within the scope that can be implemented, and the quality records shall be confirmed as necessary.

- It shall be conducted based on II-2-50- Att 4-8 Table-6 Check items (discharge vertical shaft (upper-stream storage)).

Matters to be Confirmed	Check items	Confirmation details	Acceptance Criteria
Structural strength • Seismic resistance	Visual check ※1	Check the appearance of each part.	No significant defect.
	Leakage check ※1	Conduct leakage tests in accordance with design and construction standards.	No significant leakage from any part and no drop in water level.

※1: On site, it shall be within the scope that can be implemented, and the quality records shall be confirmed as necessary.

[Reference] Items to be Checked on Inspection

- It shall be conducted based on II-2-50-Att 4-8 Table-7 Check items (discharge vertical shaft (down-stream storage), discharge tunnel, outlet).

Matters to be Confirmed	Check items	Confirmation details	Acceptance Criteria
Structural strength • Seismic resistance	Visual check ※1	Confirm the visual of each part.	No significant defect.
Functions and performance	Water flow check	Confirm water flow.	No drop in water level at discharge vertical shaft(down-stream storage).

※1:In the field, it shall be within the scope that can be implemented, and the quality record shall be checked as necessary.

In addition, since seawater is flooded into the interior of the Discharge tunnel during construction, it should be within the range that can be implemented in the field.

[Reference] Pipe Points for Structural Strength Evaluation of ALPS Treated Water Dilution/Discharge Facilities

■ Fig.1 shows the points on pipe for evaluation.

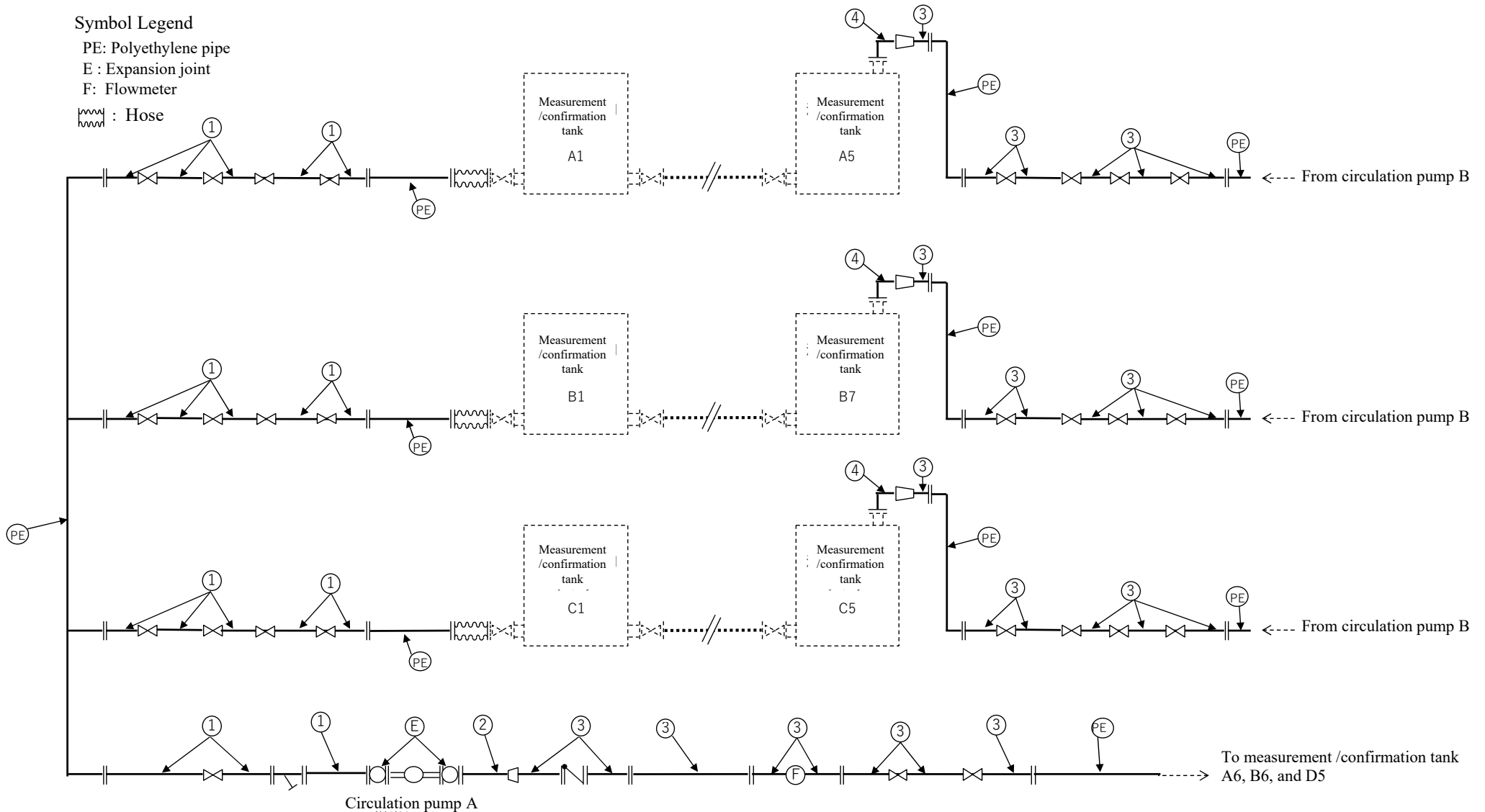

Fig. 1 Schematic diagram of pipes (1/5)

[Reference] Pipe points for structural strength assessment of ALPS Treated Water Dilution/Discharge Facilities

Fig.1 shows the points on pipe for evaluation.

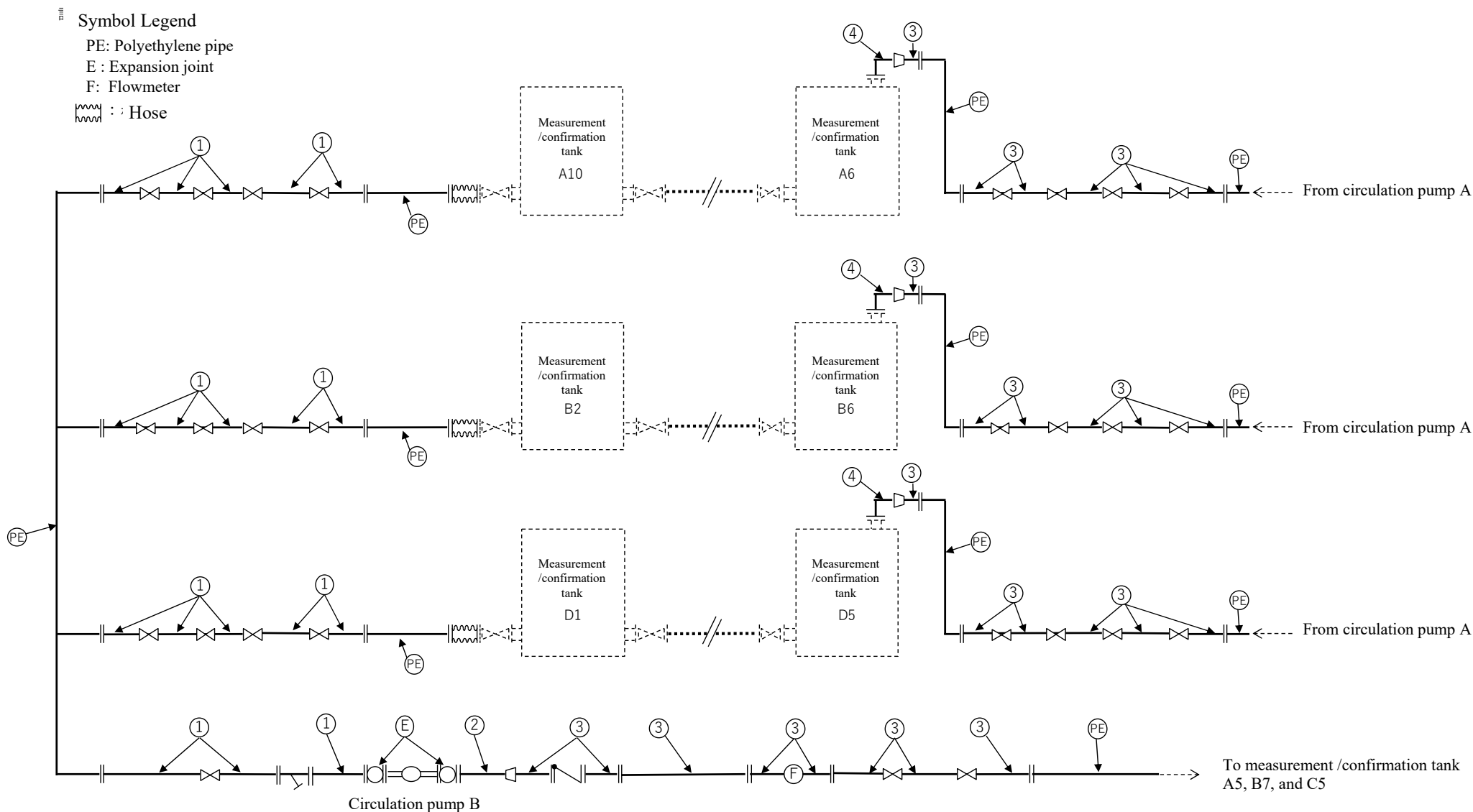

Fig. 1 Schematic diagram of pipes (2/5)

[Reference] Pipe points for structural strength assessment of ALPS Treated Water Dilution/Discharge Facilities

■ Fig.1 shows the points on pipe for evaluation.

Symbol Legend

PE: Polyethylene pipe

E : Expansion joint

F: Flowmeter

: Hose

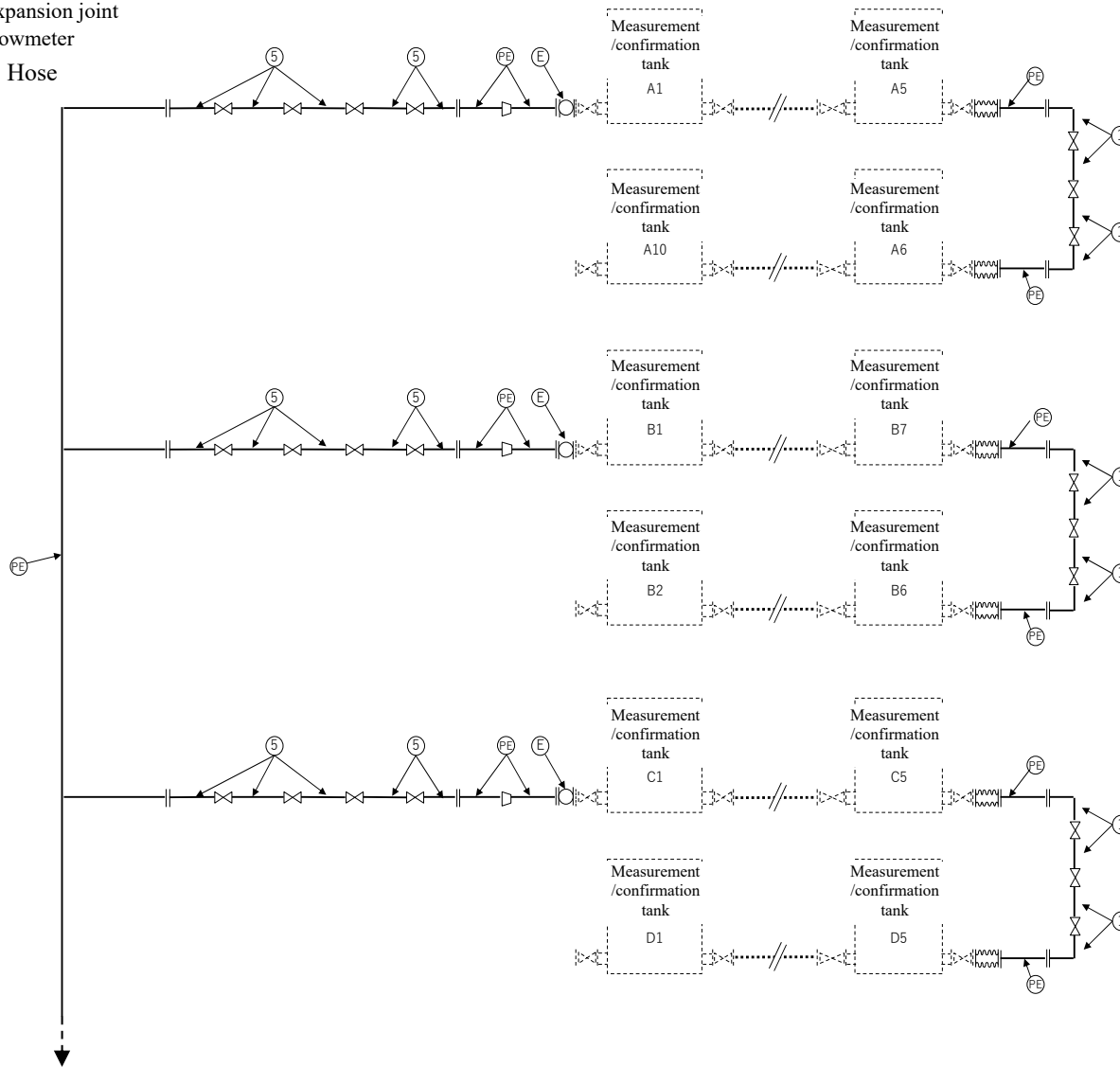

To ALPS Treated Water transfer pump

Fig. 1 Schematic diagram of pipes (3/5)

[Reference] Pipe points for structural strength assessment of ALPS Treated Water Dilution/Discharge Facilities

- The Figure below shows the evaluation points on pipe.

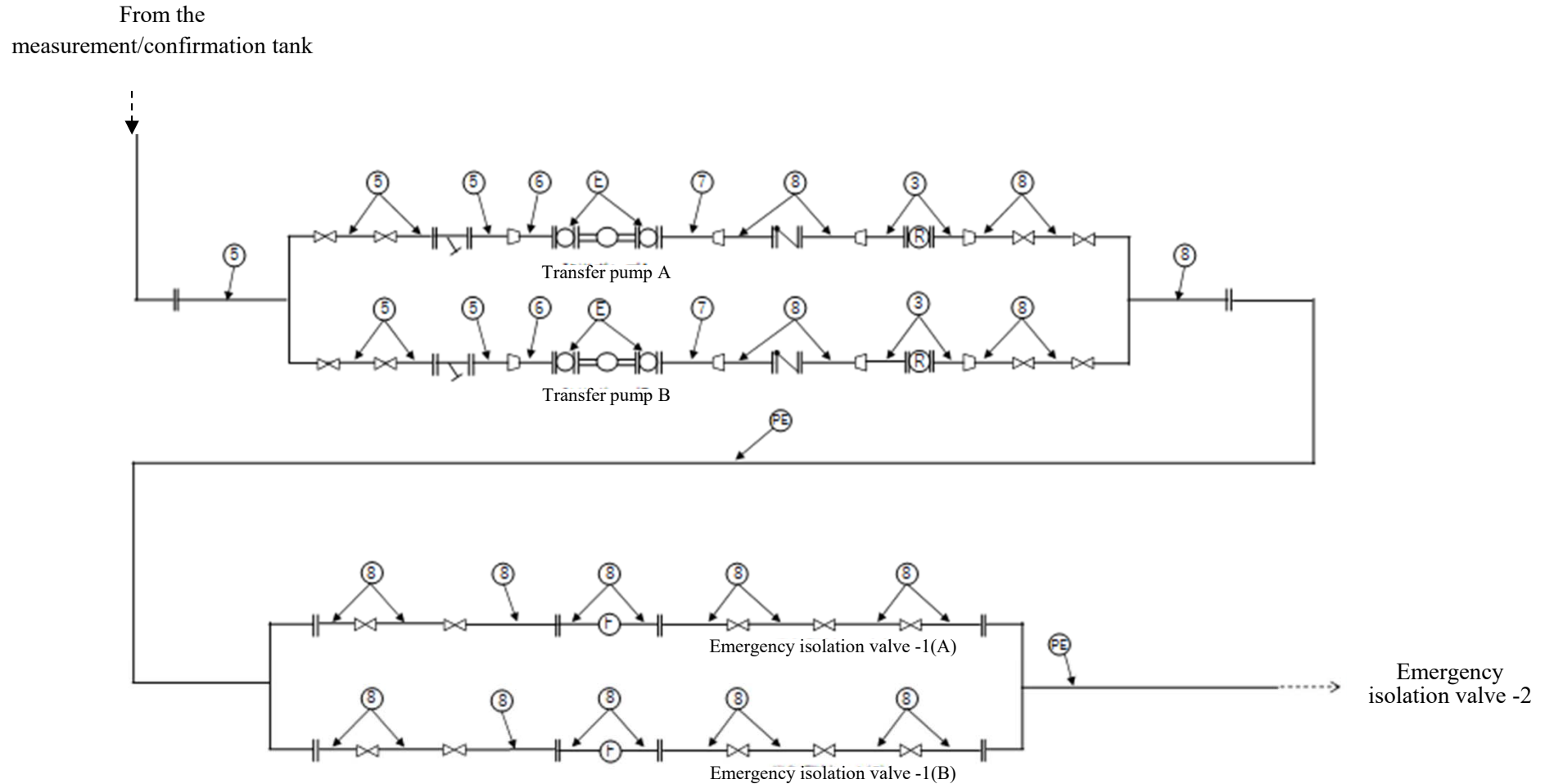

Fig. 1 Schematic diagram of pipes (4/5)

[Reference] Pipe points for structural strength assessment of ALPS Treated Water Dilution/Discharge Facilities

■ The Figure below shows the evaluation points on pipe.

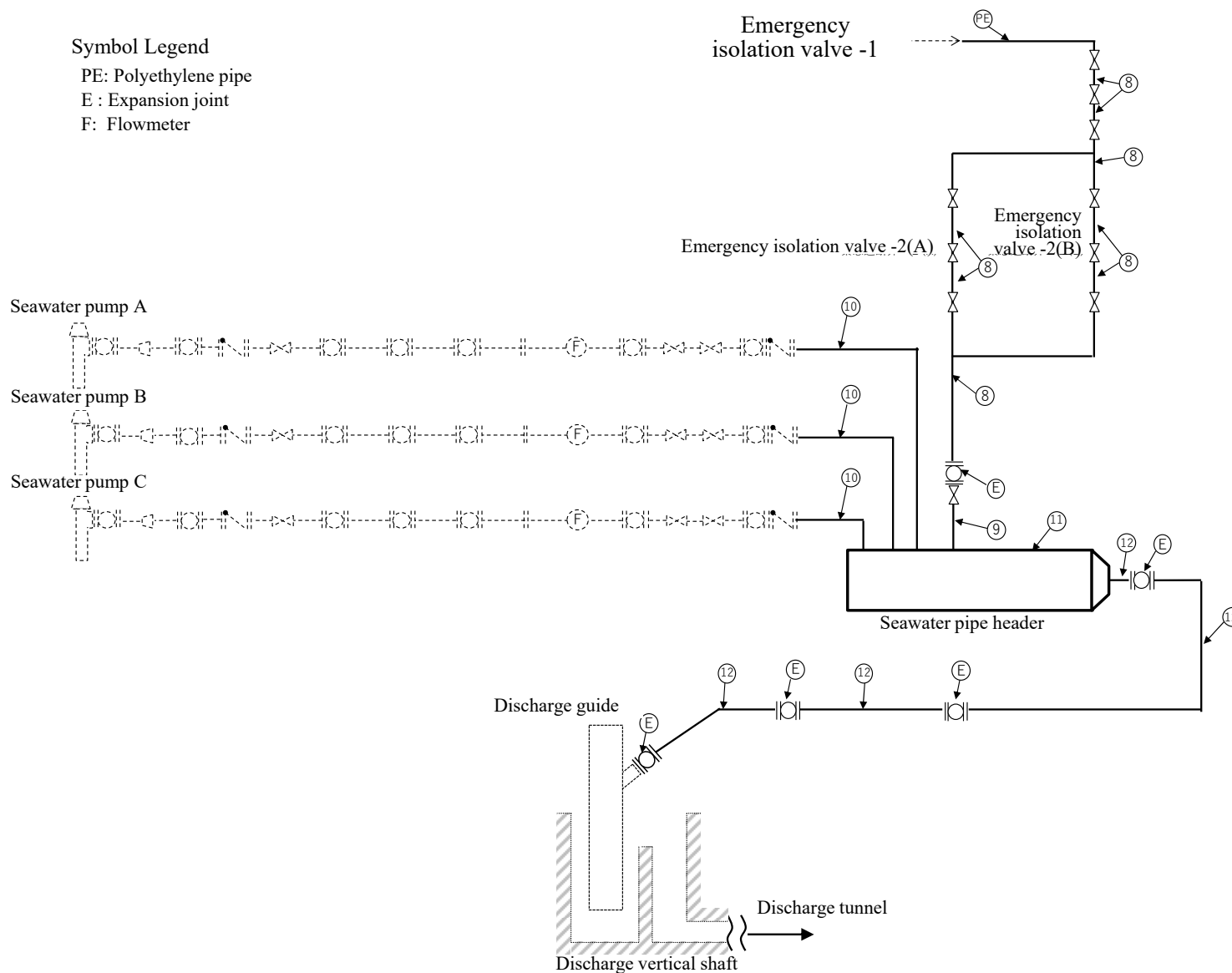
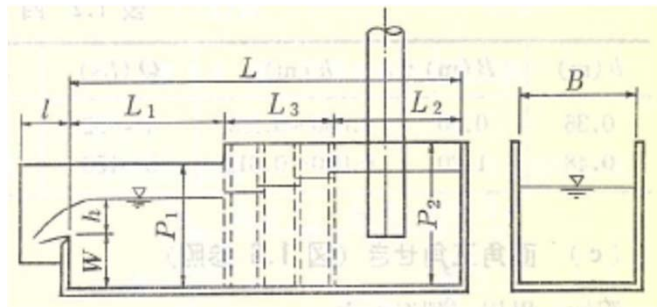
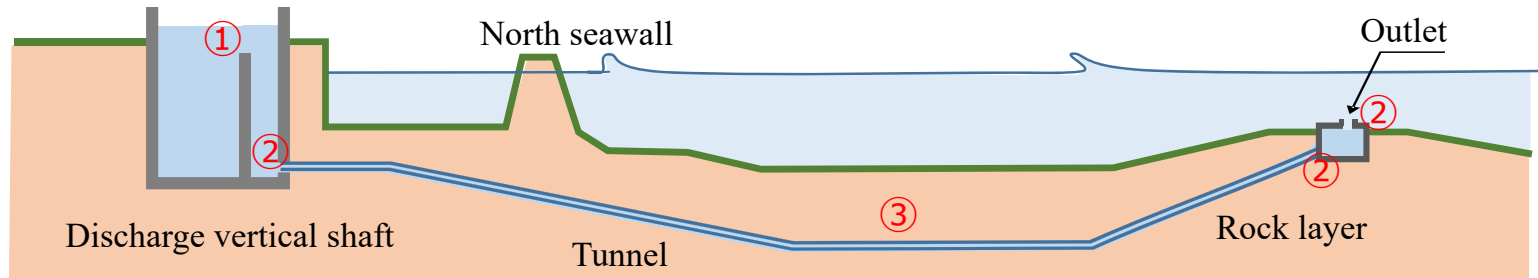

Fig. 1 Schematic diagram of pipes (5/5)

[Reference] Overview of Hydraulic Calculation for Discharge Facilities (hydraulic calculation method)

- Use Bernoulli's equation and the sequential equation for hydraulic calculations, and set the loss-coefficient based on the hydrological equation collection ※.

※ Japan Society of Civil Engineers, 1999



① Assessment of barrier (vertical shaft bulkhead section)

Ishihara-Ishida equation

$$Q = CBh^{3/2}$$

$$C = 1.785 + (0.00295/h + 0.237h/W)(1 + \varepsilon)$$

Here, Q: Overflow rate (m³/s), B: Width of barrier (m), h: Overflow depth (m), C: Overflow coefficient (m^{1/2}/s, W: Height from the bottom of the channel to the barrier edge (m), ε: If the correction factor $W \leq 1m$, $\varepsilon = 0$, and if $W > 1m$, $\varepsilon = 0.55(W-1)$

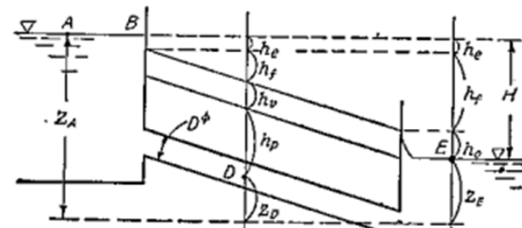

A 点: $E = z_A$

$$D \text{ 点: } E = z_D + \frac{p_D}{w} + \frac{v_D^2}{2g} + (\text{Loss of water head between A to D})$$

$$= z_D + \frac{p_D}{w} + (1 + f_e + f \frac{L}{D}) \frac{v^2}{2g}$$

However,

Loss of water head due to flow in $h_e = f_e \frac{v^2}{2g}$ (v: Flow velocity inside pipe)

Loss of water head due to friction $h_f = f \frac{L_D}{D} \frac{v^2}{2g}$ (L_D: Pipe length to D)

Flow velocity of water head $h_v = \frac{v_D^2}{2g} = \frac{v^2}{2g}$

Pressure of water head $h_p = \frac{p_D}{w}$

$$E \text{ 点: } E = z_E + (\text{Loss of water head between A to E})$$

$$= z_E + h_e + h_f + h_v$$

Hydraulic calculation equation for constant section pipelines (hydraulic equation collection)

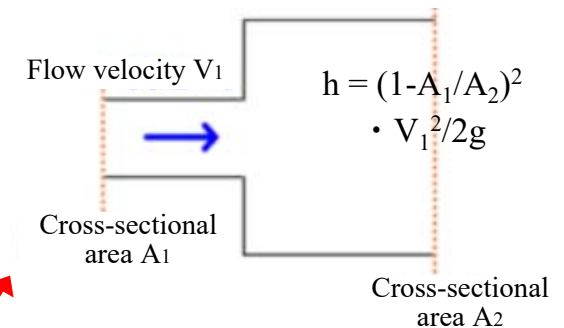

② Loss of water head (tunnel, outlet part) due to shape change (sudden expansion and contraction)

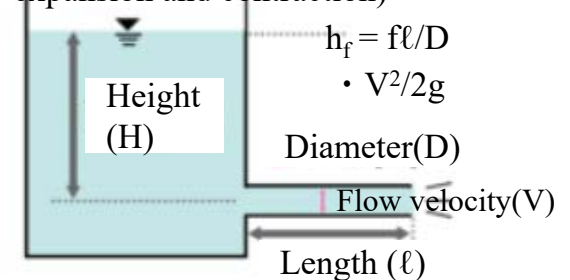

③ Loss of water head at circular tube (tunnel section) due to friction

[Reference] Overview of Hydraulic Calculation of Discharge Facility (surging analysis)

- Water level fluctuation in abnormal situations shall be calculated because surging may occur in tanks and tunnels due to abnormal stoppages of pumps (earthquakes, tsunamis, etc.).
- It shall reflect the conditions corresponding to the design wave height (50-year probability significant wave height: 7.0m) and storm surge (past peak tide level: TP + 1.15m) in the analysis.

Analysis conditions and results

Item	Numerical value
Tide level	TP+0.757m (HWL)
Flow rate	6m ³ /s (3 pumps in operation)
Pump stop time	30 seconds (pump stops 1,000 seconds after calculation starts)

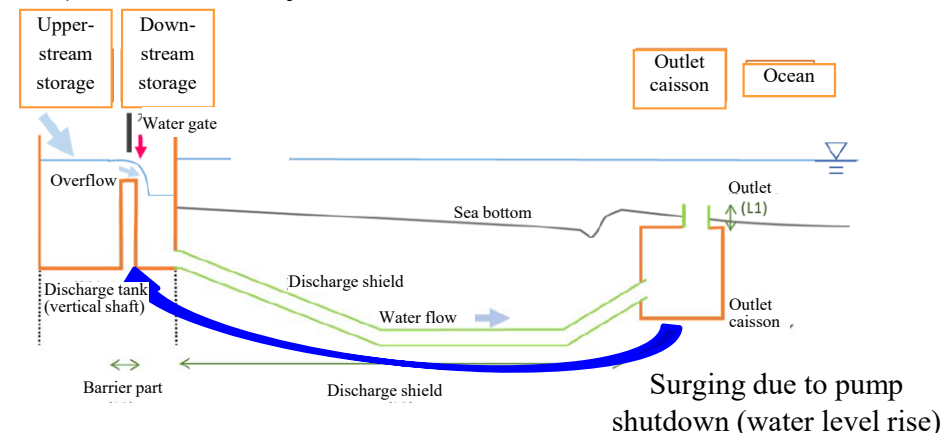

Schematic diagram of the discharge facility

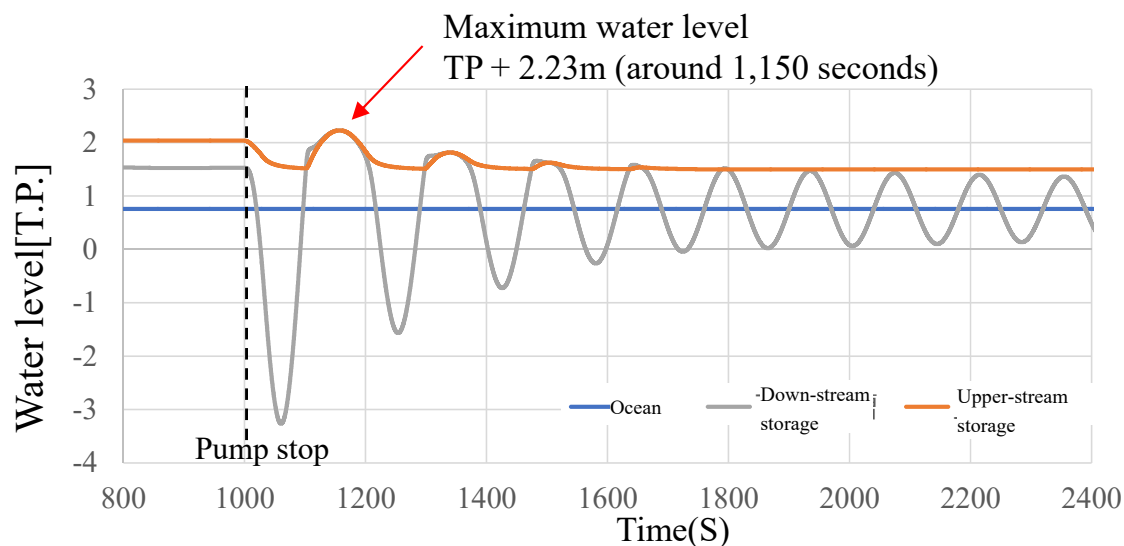

Time-series changes in water level

Maximum water level of the discharge vertical shaft	Height of the discharge vertical shaft crest
T.P.+2.23m	TP+4.50m
⇒ No flooding	

[Reference] Overview of the structure of the discharge facility (water stop of the discharge tunnel)

■ Concept of water stop

- The shield shall be a two-stage seal because of the action of internal water pressure.
- A water stop sealant (rubber that exhibits water stop performance due to water expansion) shall be installed on the inside and outside of the segment.
- Since the joint is placed inside the sealant, corrosion, etc. does not occur even in an environment exposed to sea water for a long time.
- Segments shall be assembled with multiple pieces into a circular shape, and each pieces shall be connected each piece by a steel joint.
- Steel joints shall be placed on the sides of the segments and not be exposed on the inner surface after assembly.
- Since joints without fastening force cause water leakage by generating openings and differences in seams at the time of assembly, it shall adopt a joint structure with high fastening force having a good track record of construction in many shield tunnels.



[Reference] Overview of the soundness of discharge facilities (structure) **TEPCO**

- Check for stress level
- Among the materials used for the discharge facilities, concrete shall be ordinary concrete (ordinary Portland cement, blast furnace cement type B) and the design standard strengths shall be 24N/mm², 30N/mm², and 42N/mm². Rebar shall be SD345.
- Ensure that the stress level in the material caused by the action of the load shall be within the allowance stress level.

Allowance stress level of concrete

Design standard strength of concrete	Long-term		Short-term		Remarks
	Compression (N/mm ²)	Shear (N/mm ²)	Compression (N/mm ²)	Shear (N/mm ²)	
24N/mm ²	9.0	0.45	13.5	0.675	Discharge vertical shaft (down-stream storage)
30N/mm ²	11.0	0.50	16.5	0.75	Outlet
42N/mm ²	16.0	0.73	24.0	1.095	Discharge tunnel

Allowance stress level of reinforcement

Materials used	Long-term	Short-term
	Tension (N/mm ²)	Tension (N/mm ²)
SD345	200	300

[Reference] Overview of the soundness of discharge facilities (crack width)

Check for crack width

- Check for crack width shall be performed by the following equation to confirm that the crack width (W) of the concrete surface is below the critical value (w_a) of the crack width for corrosion of the steel material.

$$w/w_a \leq 1.0$$

Crack width (w)
$$w = 1.1 \cdot k_1 \cdot k_2 \cdot k_3 \{4c + 0.7(c_s - \phi)\} \left[\frac{\sigma_{se}}{E_s} + \varepsilon'_{csd} \right]$$

Here,

k_1 : A coefficient that represents the impact of crack width on the surface geometry of a steel material. Generally, it is 1.0 for deformed rebar

k_2 : The coefficient that has impact on the crack width from the quality of concrete, according to the following equation,

$$k_2 = \frac{15}{f'_c + 20} + 0.7$$

f'_c : The compressive strength of the concrete (N/mm²), generally designed compressive strength f'_{cd} is used.

k_3 : The coefficient that represents the impact of the number of steps n of the tensile material, according to the following equation,

$$k_3 = \frac{3(n+2)}{7n+8}$$

c: Covering depth (mm), c_s : Center spacing of steel (mm), ϕ : Steel diameter (mm),

σ_{se} : Increase in the stress level of the rebar (N/mm²),

ε'_{csd} : Strain to consider increased cracking width due to concrete shrinkage and creep

(Approximately 150×10^{-6} is used for the ε'_{csd} of when checking for corroded materials.)

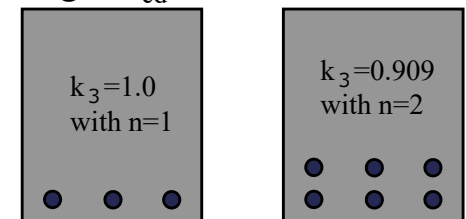

Schematic diagram of the relation between the number of steps n and k_3

[Reference] Overview of the soundness of discharge facilities (salt damage)

■ Check for salt damage

- It shall be confirmed that the chloride ion concentration at the steel position does not reach the limit concentration of corrosion during the design service period.
- Determined the limit value of crack width for corrosion of steel materials according to environmental conditions, covering, and type of steel material.
- The environmental conditions shall be corrosive environmental conditions, and the limit value of crack width shall be 0.004c (mm) (c: pure covering)

	Checking equation
Calculation equation for Design diffusion coefficient	$D_d = \gamma_c \cdot D_k + \left[\frac{w}{l} \right] \cdot \left[\frac{w}{w_a} \right]^2 \cdot D_0$
Calculation equation for designed chloride ion concentration at steel position	$C_d = \gamma_{cl} \cdot \left\{ 1 - \operatorname{erf} \left(\frac{0.1 \cdot C_d}{2\sqrt{D_d \cdot t}} \right) \right\}$
Checking equation for designed chloride ion concentration at steel position	Design value for chloride ion concentration is less than corrosion occurrence limit concentration at steel position $\gamma_i \cdot \frac{C_d}{C_{lim}} \leq 1.0$

D_d : Designed diffusion coefficient

D_k : Diffusion coefficient properties (cm²/year) for chloride ion in concrete

D_0 : Coefficient (cm²/year) that represents the impact of cracking on the transfer of chrominance in the concrete. Generally 200cm²/year

w : Crack width (mm)

w_a : Crack width limit for corrosion of steel (mm)

w/l : Ratio of crack width to crack spacing

C_d : Designed values of chloride ion concentration at steel position

[Reference] Overview of the soundness of discharge facilities (floating)

■ Check for floating

Check for floating shall be performed by the following equation.

$$F_s = W/U$$

$$U = V_w \cdot \gamma_w$$

U : Buoyancy (kN)

W: Vertical load (kN)

V_w: Volume below ground water level (m³)

γ_w: Unit volume of water (seawater) (kN/m³)

	In service	
Applicable conditions	At all times and in ocean waves	During an earthquake
Floating safety factor	1.20	

- Design considerations for tsunamis
 - Because flooding by tsunami is not avoidable, this facility shall have wave pressure resistance (target: Japan Trench Tsunami) according to the recoverability of this facility.
 - With the emergency shutdown of the pump, the occurrence of surging in the tanks and the tunnel is a concern. Calculate and check the impact of the inundation of land areas and the fluctuation of water level in discharge facilities.
- Design considerations for typhoons (storm surges)
 - The design wave height (50-year probability significant wave height: 7.0m) surge and storm surge (past peak tide level: TP + 1.15m) conditions shall be reflected in the structure design and surging analysis, and the impact on discharge facilities due to changes of ocean waves shall be confirmed.
 - The inside of the tunnel (segment) shall be designed in case of the occurrence of design wave height (50-year probability significant wave height: 7.0m) surges and storm surges (past peak tide level: TP + 1.15m).